

T6+CP carrying a unique method of displaying the white 'African Front' colour, the infamous 'Sand Snake' individual marking of 11/St.G 2. This scheme would have been extremely short lived even accepting the compromise in camouflage and hence vulnerability. the unit was absorbed into St.G 3 at the end of 1941 when most aircraft were fully or partially repainted. Recorded in Aug 1941 the machine was camouflaged in Sand 79 with Green 80 splinter pattern on the wings and sweeping bands on the fuselage in the same colour. The snake pattern was applied in White 21 so that the camouflage showed through as the snakes patches, retouched sparingly in the sand colour. The head of the snake only had the centre and the first two patches at least fully painted in the later production Sand Yellow 79 (A Tan rather than a Sand shade).- much Walkways are scuffed down to the original 70/71 pattern. Camouflage details and unit code are confirmed by photographs, Individual and Staffel letters based on those reported to have been carried.

30 Underwing cross; 31 Upperwing cross; 32 Fuselage cross; 33 Fin swastika; 48 Codes for St.G 3; 49 Individual letter; 50 Staffel letter; 51 Snake (Port); 52 Snake (Stbd); 53 Spat letter; 54 Underwing letter; 29 Partially obscured fuel octane triangle.

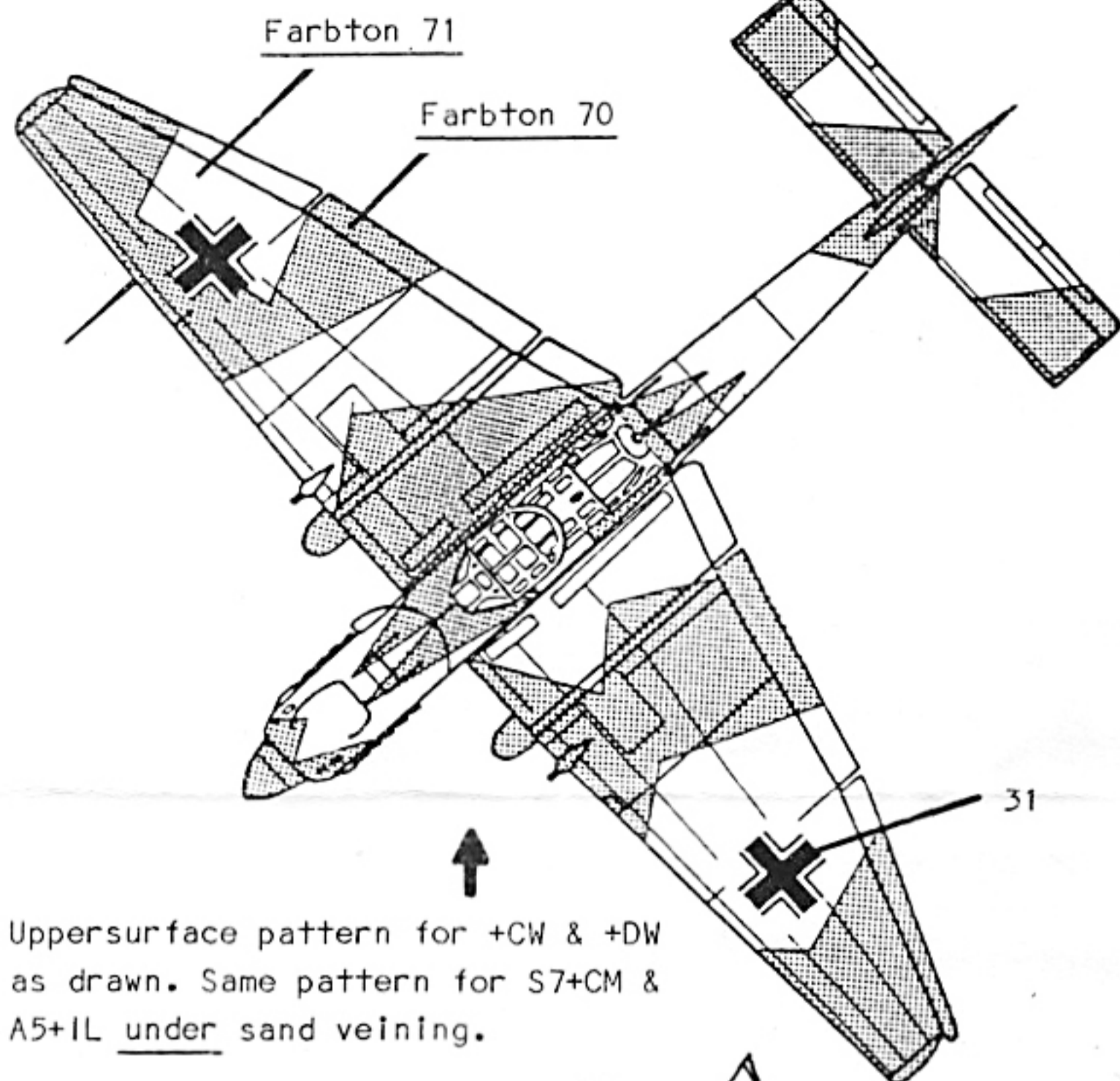

↑
Uppersurface pattern for +CW & +DW as drawn. Same pattern for S7+CM & A5+IL under sand veining.

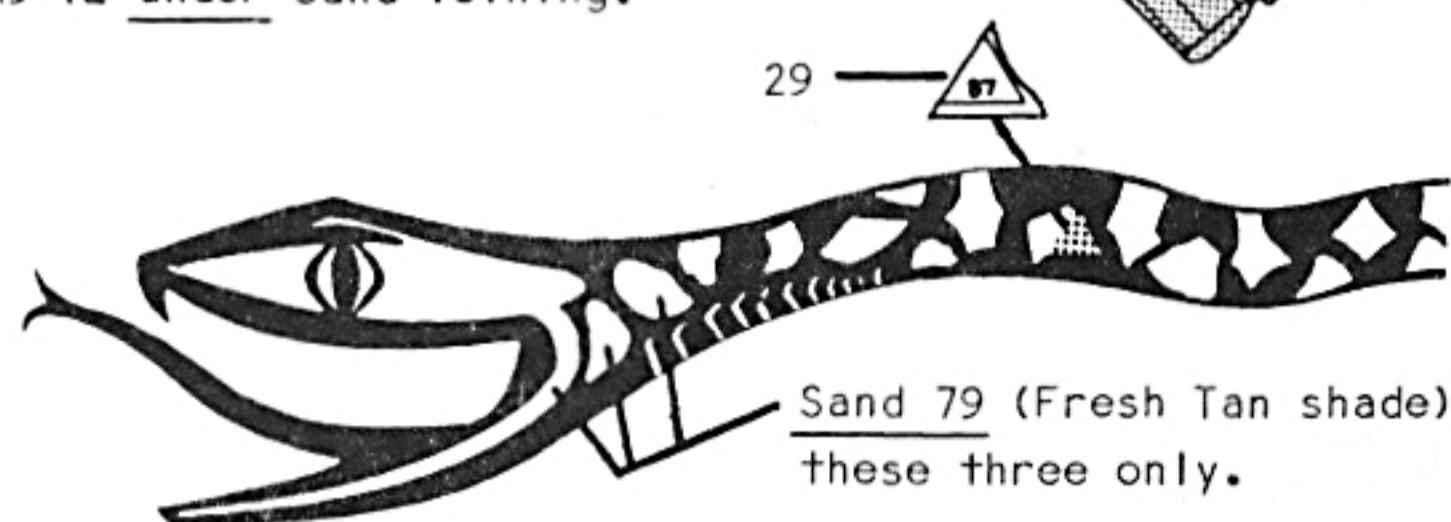

Sand 79 (Fresh Tan shade) these three only.

Trim tongue on application to fit exhausts.

Snake white areas drawn in black on illustrations for clarity.

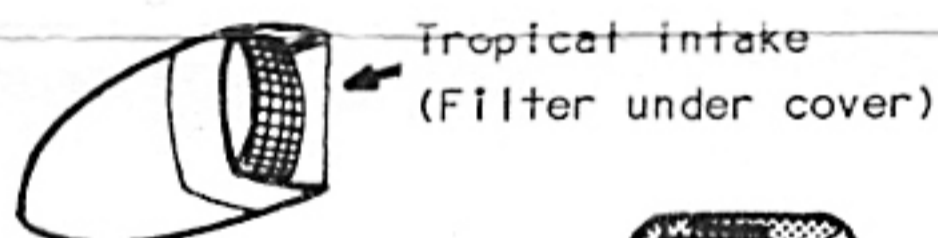
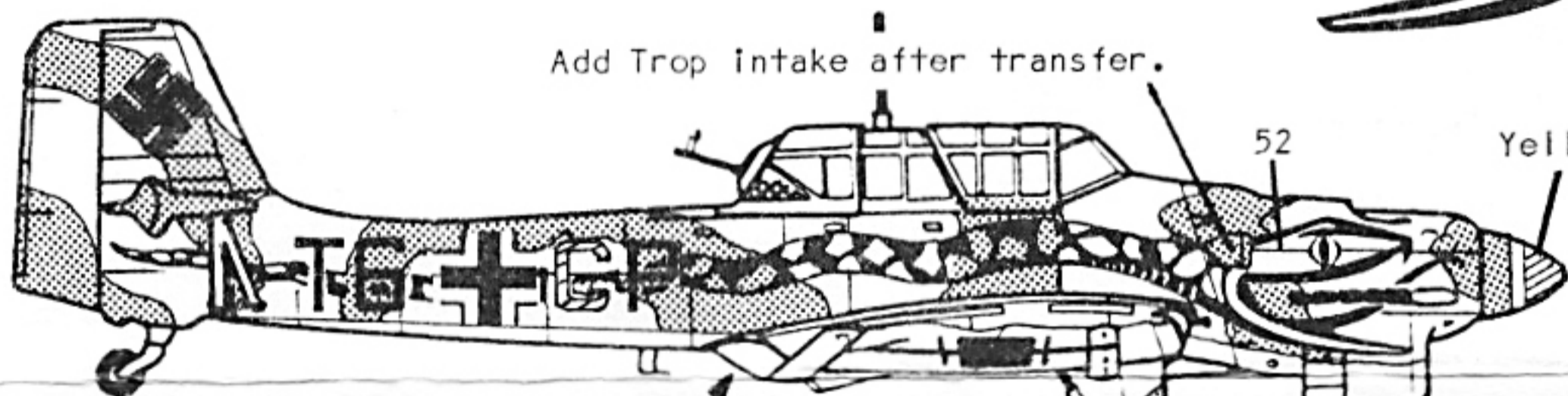

Aircraft of Lt. Hubert Polz based at Tmimi, Lybia, August 1941. Pilot non-operational shortly after.

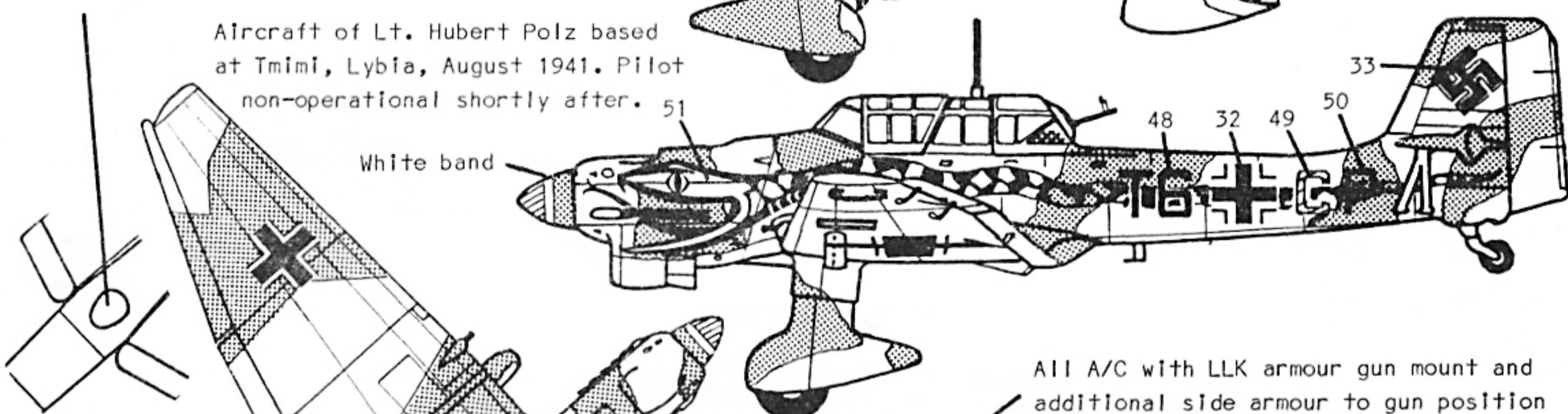

Farbton 78 undersides - all aircraft.

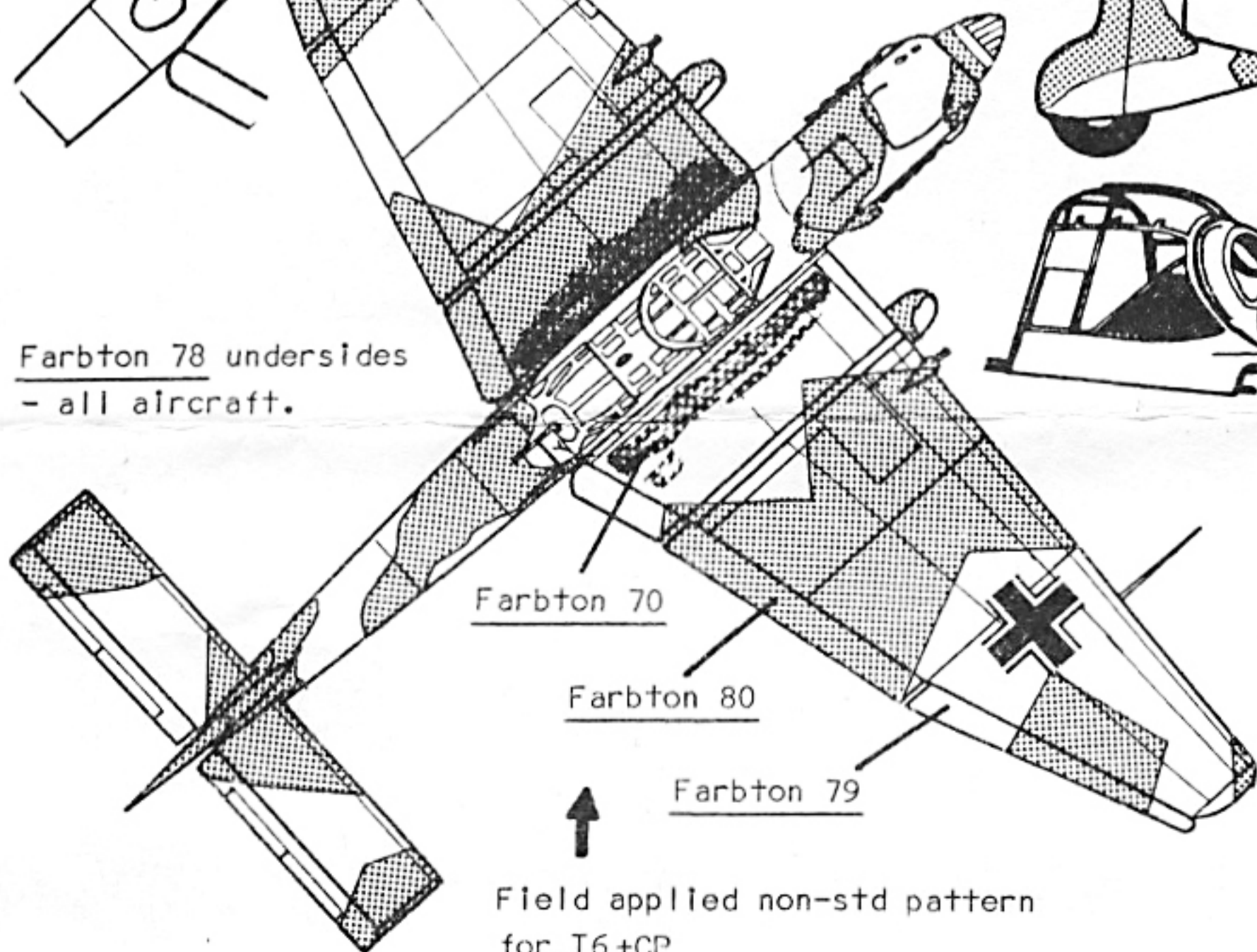

E.D. Models

JUNKERS Ju 87 B & R
SHEET C8
Tropical Stuka's

E.D. MODELS., 64 STRATFORD ROAD,
SHIRLEY, SOLIHULL B90 3LP,
ENGLAND. Tel: 021-744-7488

Research by Les Whitehouse.

L1+CW operating in Finland during 1942 in support of Axis forces. Typical of supply anomalies this machine is full production tropical build supplied direct as replacements and repainted by overspraying the Sand Yellow 79 uppersurfaces with Farbton 70/71. Undersurfaces remain in Farbton 78. Areas of sand remain as background to stencils and hard to mask areas. Yellow wing tips underneath, yellow band under fuselage crosses, yellow nose to spinner. 30 Underwing crosses; 31 Upperwing crosses; 32 Fuselage cross; 33 Fin swastika; 42 Codes for Lehrgeschwader 1; 43 A/C marking; 44 Staffel letter; 45 Spat marking; No unit badge displayed by IV/LG 1.

As an alternative its sister aircraft can be modelled, L1+DW.
46 replaces 43; 47 replaces 45.

S7+CM at El Adem mid-June 1942. Formerly operating as 1/St.G 1 (this a/c coded A5+CH), the entire Gruppe was redesignated 11/St.G 3 early in 1942. It retained the diving crow emblem but remarked all but the individual letter progressively during 1942.

Camouflage is Sand Yellow 79 sprayed as a veining over original Farbton 70/71 camouflage. Spat letter on the original 70 with hard edges, rest not masked shows much overspray. Repairs and original codes covered with Green 80. White spinner tip.

30 Underwing crosses; 31 Upperwing crosses; 32 Fuselage cross; 33 Fin swastika; 34 Codes for St.G 3; 35 A/C marking; 36 Staffel marking; 37 Spat marking; 38 Unit badge; 24 Radiator stencil.

As an alternative A5+IL in late 1941 demonstrates the same scheme but original 3/St.G 1 coding and yellow spinner front half.

39 replaces 34; 40 replaces 35; 41 replaces 36; 37 not applied.

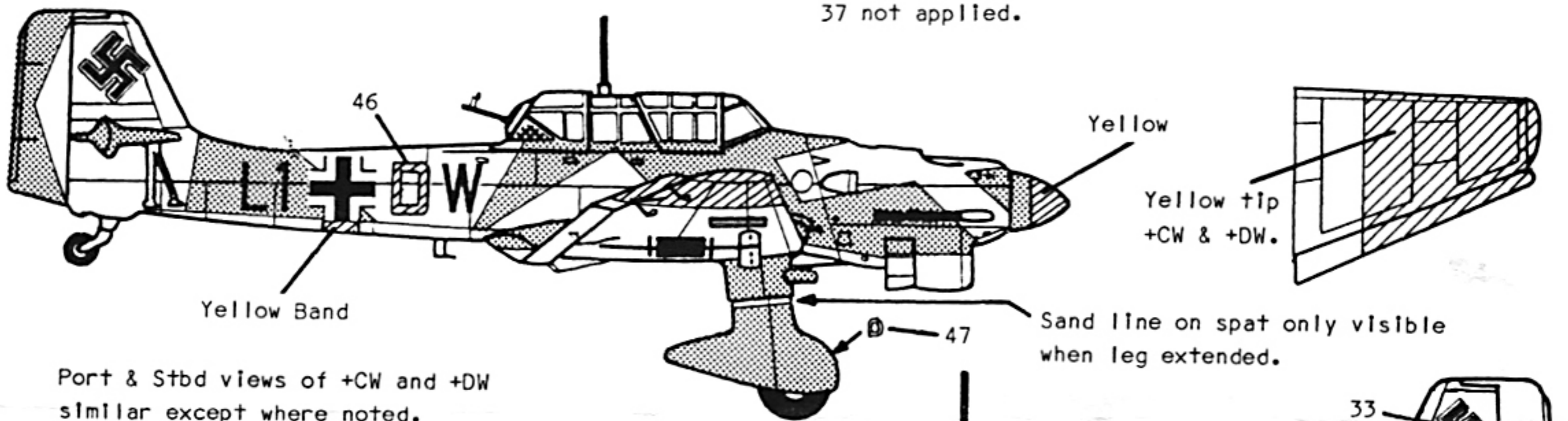

Port & Stbd views of +CW and +DW similar except where noted.

All stencils retain Sand background.

Wing gun fairing front - Sand 79

Sand 79 patch both sides on +CW
Coolant marking half on Sand, half on Blue 78.

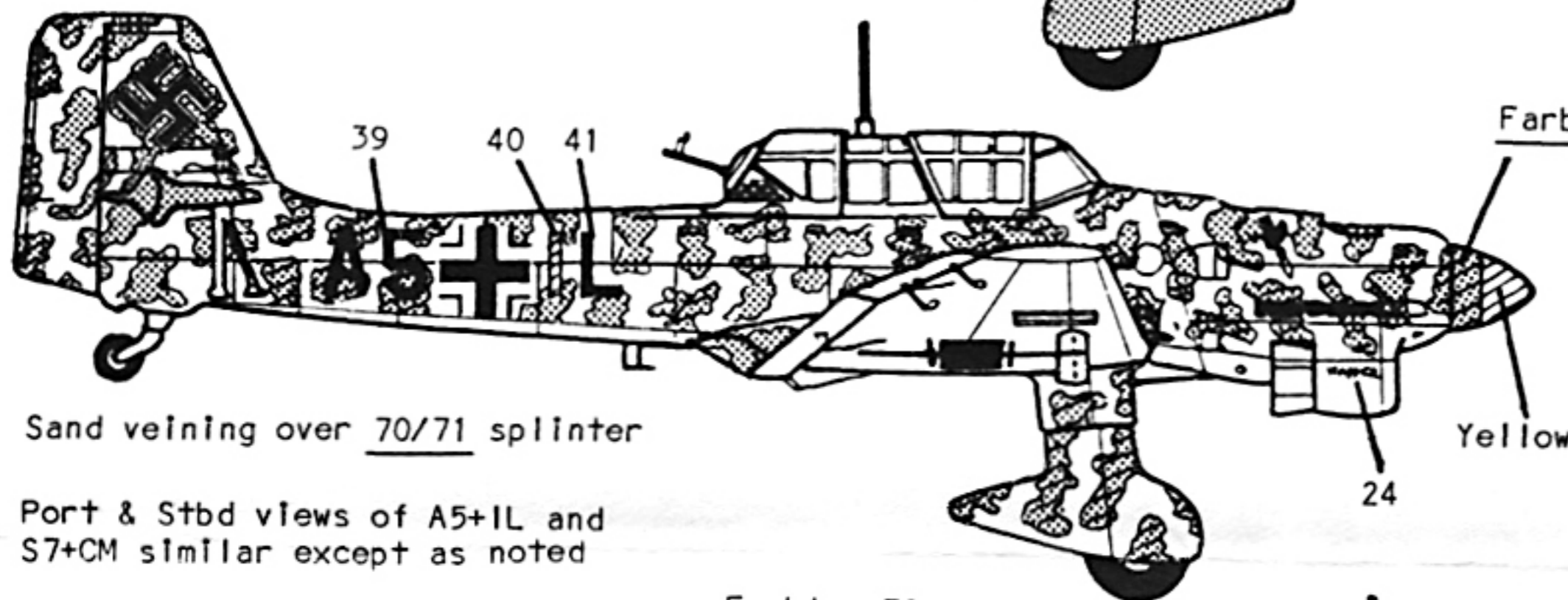
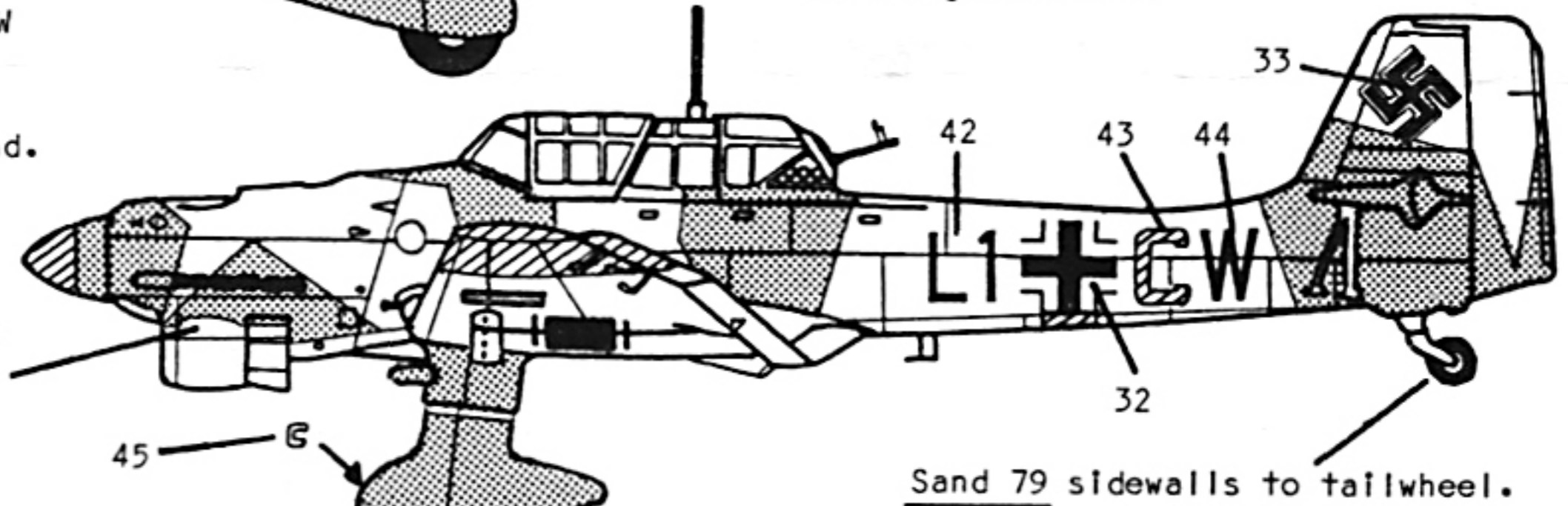

Port & Stbd views of A5+IL and S7+CM similar except as noted

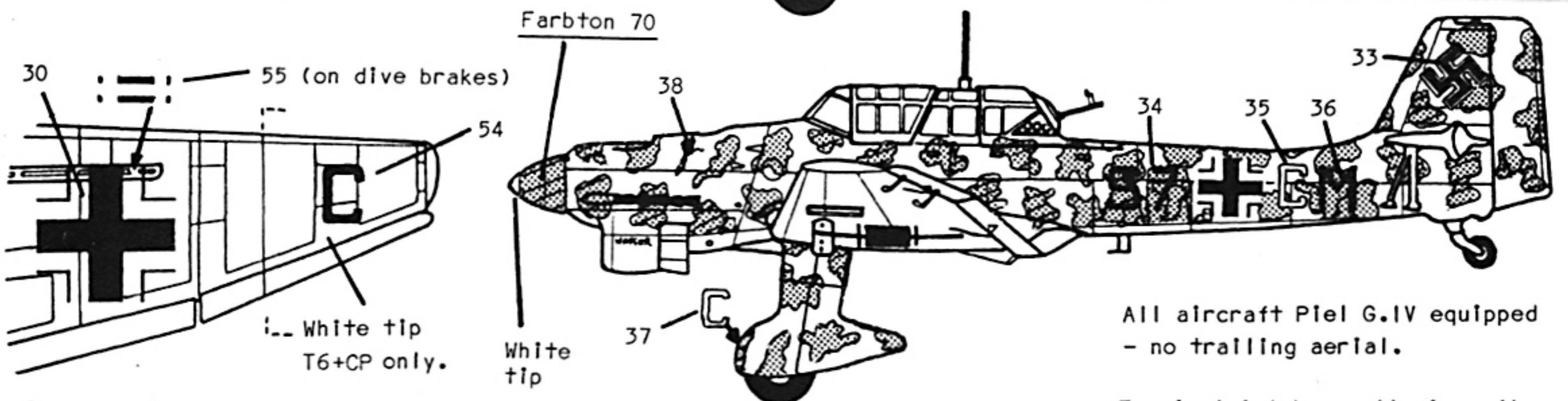
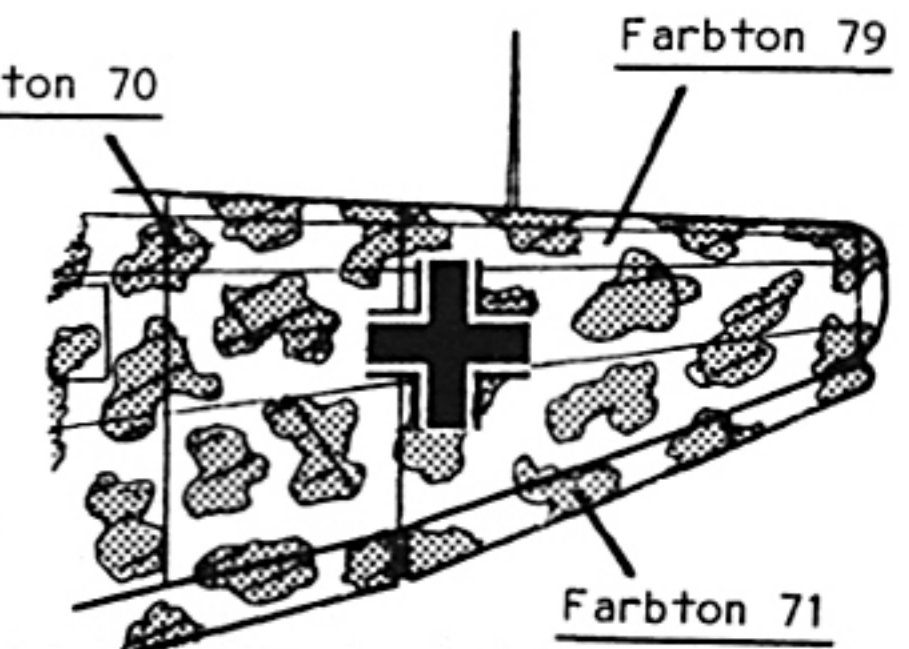

All aircraft Piel G.IV equipped - no trailing aerial.

Tropical intake - all aircraft.

ITEM	COLOURS	REMARKS
1	White	On aerial mast - 'Caution, Do not Touch'
2	White	On spat - Landing gear leg pressure
3	White	On spat - Tyre Pressure
4	White	Oil tank capacity (Port side only) - in conjunction with item 12
5	White	On leg fairing, port side both legs - 'Short bolt here'
6	White	On leg fairing, stbd side both legs - 'Short bolt here'
7	White	Base of rear fuselage - Tyre Pressure sometimes applied in red
8	Red	Rear fuselage above trestle tube - 'Ballast here' Sometimes Hier Aufbocken 'Jack here'
9	Red	On inboard flap and top of spat - 'No Step'
10	Red	Reinforced areas for lifting wing or aircraft in nose down attitude
11	Red/Black	Electrical socket - Both sides but at different positions
12	Red-Brown & White	Oil Triangle, port side only
13	Blue/White	Oxygen marking, with text 'oxygen, keep free from oil and grease'
14	Yellow/ White	Fuel Triangle, both sides with white arrow pointing to filler cap on wing
15	Black	Coolant marking on radiator cowl
16	Black	'Jack here' - under wing
17	Red/White	First Aid marking on plexiglass panel (Port only)
18	Black	Under wing - 'Short bolt here'
19	Black	On R models only - 'Tighten retaining strap after filling tank'
20	Black	Under outer wing - 'Control lock here'
21	Black/ Silver	Metal data plate either side of spat
22	Black/ Silver	Metal data plate port side fuselage
23	White	Stencil applied to engine cowl of early machines particularly III/St.G 51 and hence II/St.G 1 - Believed to refer to oil cooler and need to leave this uncovered when ground running engine
24	Black	'Water' - In place of item 15 on some desert machines, particularly I/St.G 1 and hence II/St.G 3
25	Red	Alignment mark on camera gun blank plate
26	Black/ Silver	Metal data plate on Elevator balance weight
27	Black/ White	Junkers emblem on early prop blades
28	Black/ White	Later prop blade emblem

NOTE: ITEM NUMBERS FOR B & R models ARE
NOT NECESSARILY INTERCHANGABLE
WITH THOSE FOR D & G models.

THE FOLLOWING STENCILS ARE OMITTED
ON AIRCRAFT STATED:

6G+FR & +AR: Item 23 must be applied
Omit items 2,4,19,24,28.

6G+KT & +AT: Omit items 2,4,23,24,
27.

Wk Nr. 0353: Omit items 2,8,23,24,
27,28. Plus any freshly overpainted.

T6+MP: Omit items 2,4,19,23,24,27,
28.

S7+CM: Omit items 2,3,4, Top half
of 10,19,23,27,28. Use item 24 in the
place of 15.

A5+IL: As S7+CM but note SS in WASSER
like the SS runes on this a/c.

L1+CW & +DW: Use sand background to
stencils and Omit 2,4, Top half of
10,23,24,27,28.

E.D. Models

JUNKERS Ju 87 B & R
STENCIL DETAILS

E.D. MODELS., 64 STRATFORD ROAD,
SHIRLEY, SOLIHULL B90 3LP,
ENGLAND. Tel: 021-744-7488

Research by Les Whitehouse.

PORT ONLY:
4, 12, 17, 22,
23.
STBD ONLY:
13.
OTHERS BOTH
BUT 11 IN
SEPARATE
POSITIONS

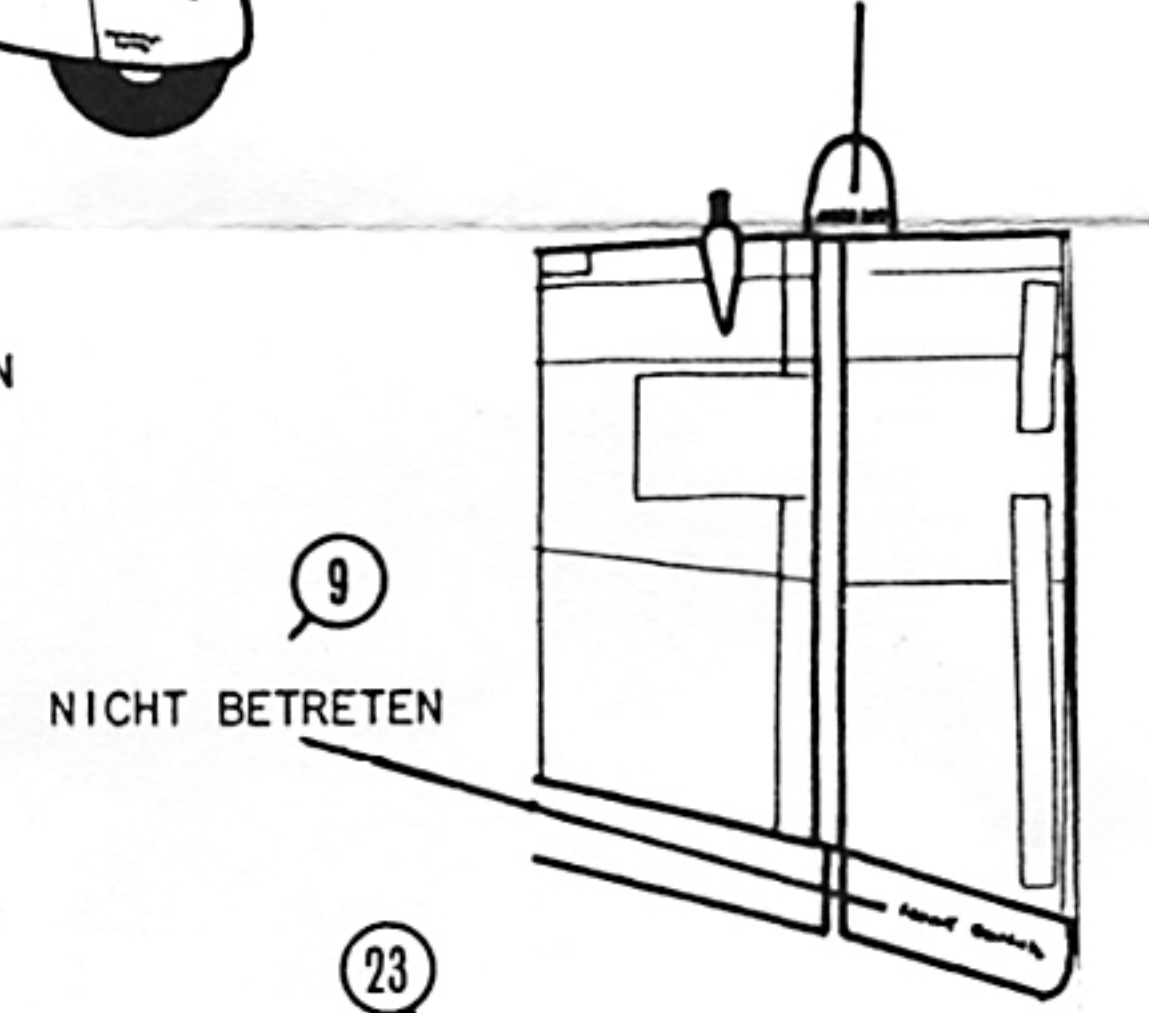
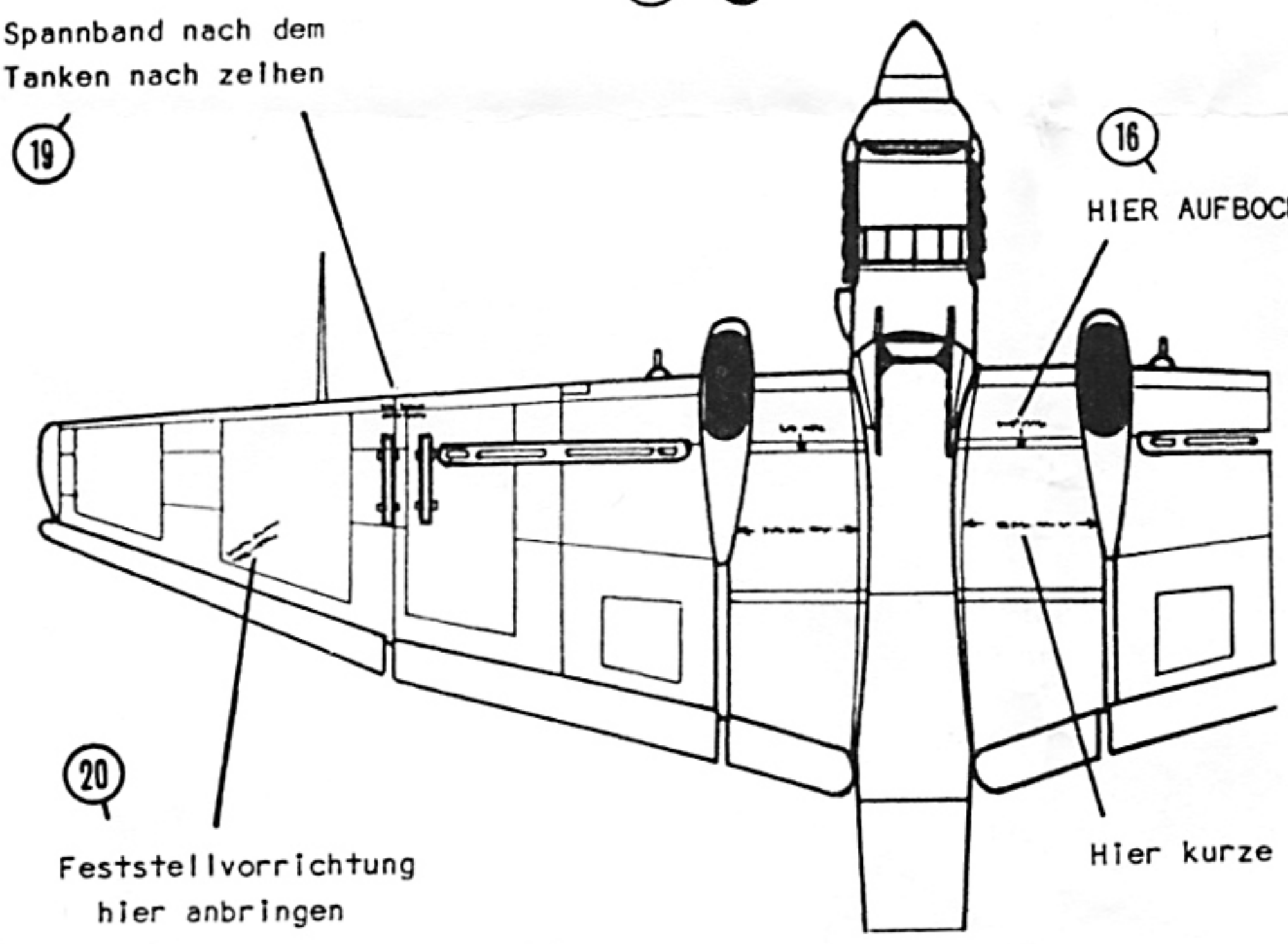
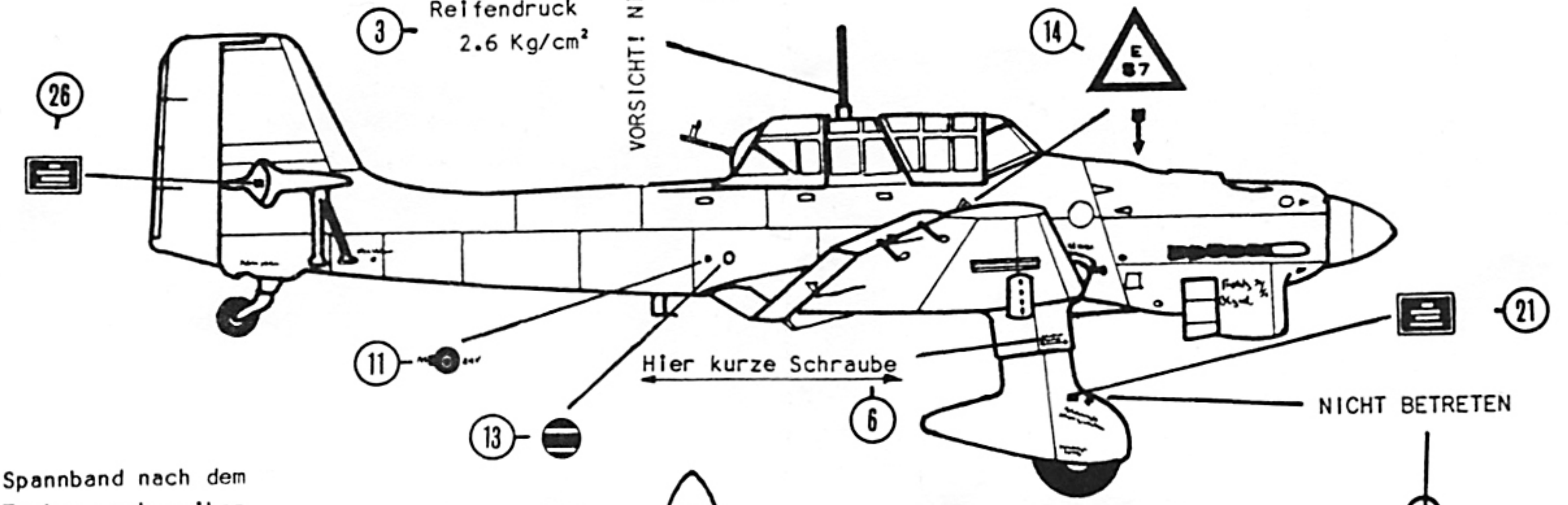
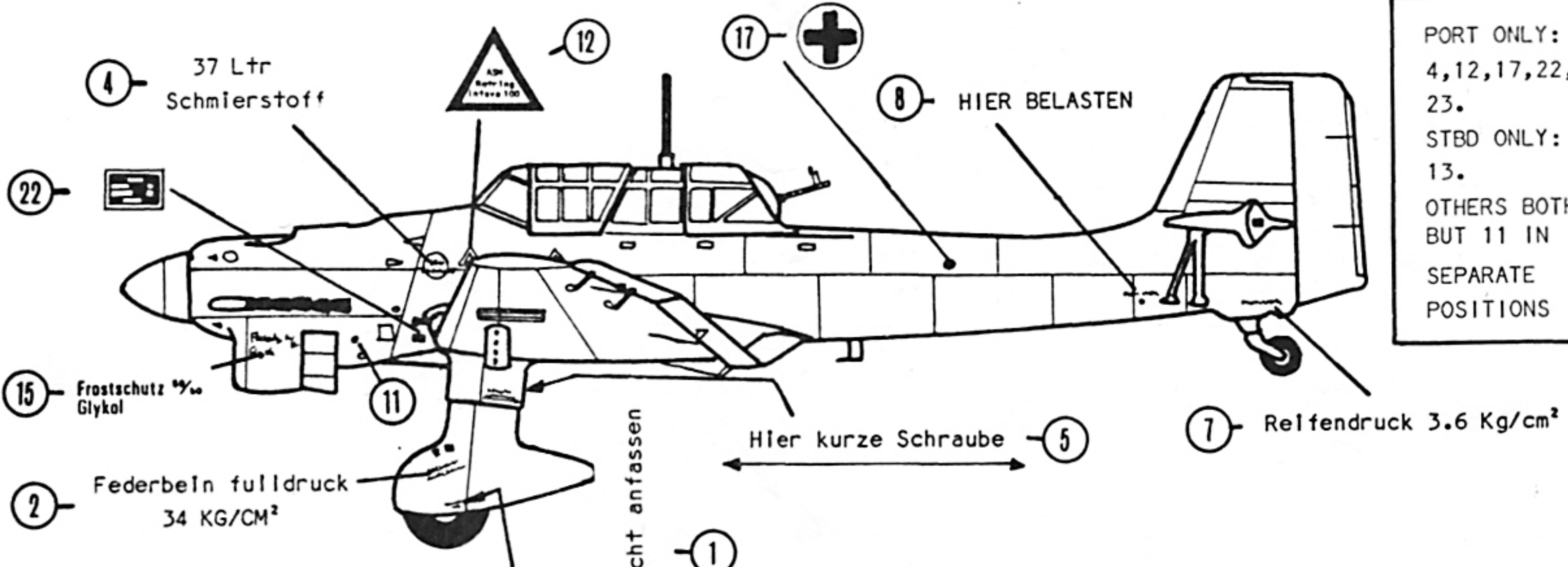

Ölkehlief hinaufbaut
im motoren abstart nicht
die luftschutz koerper auf

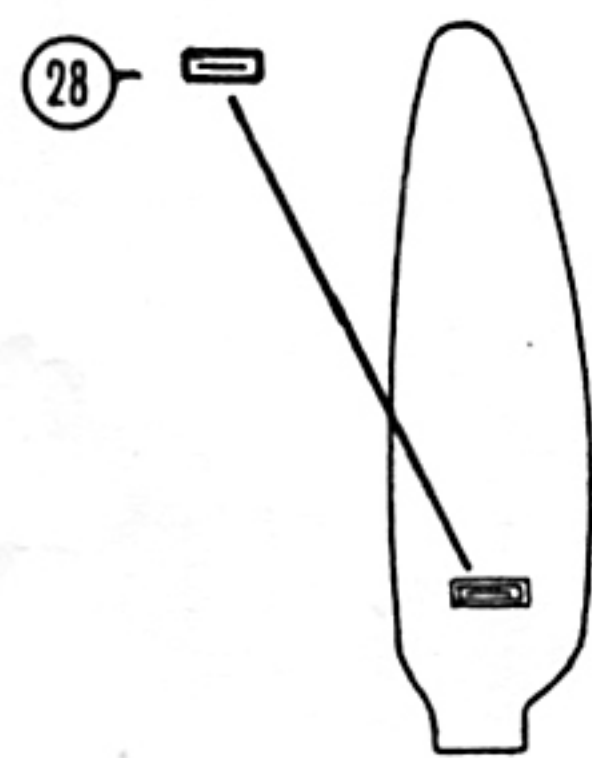
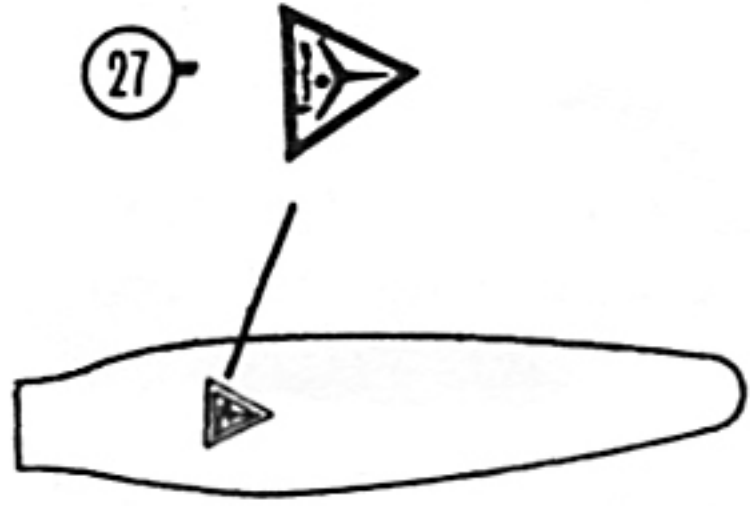
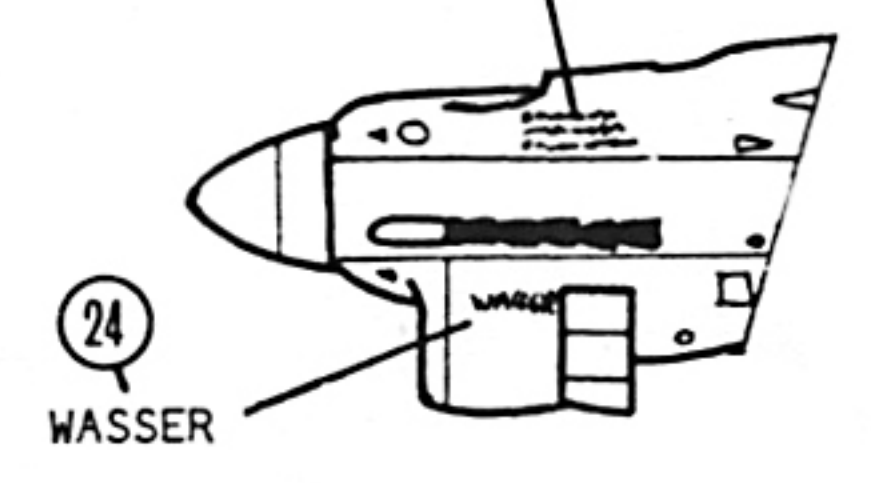
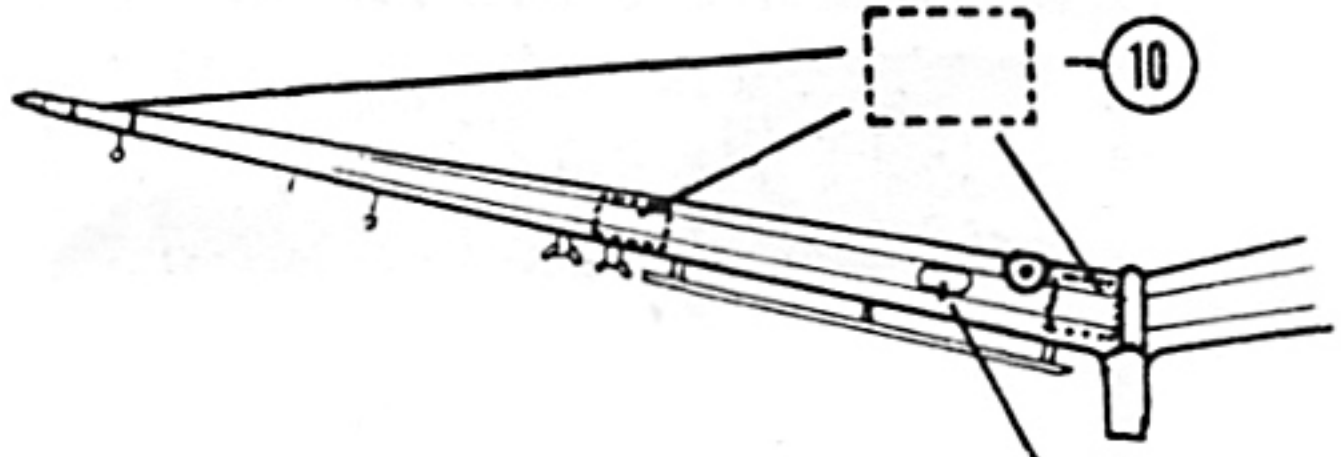

© Les Whitehouse