



HGW

MESSERSCHMITT BF 109E-7 TROP 1/32 LIMITED EDITION



Přátelé, dostáváte do rukou první stavebnici firmy HGW. Výlisky mají původ u firmy Dragon, Cyberhobby, toto byla od HGW výborná volba. Model patří mezi to nejlepší ve své kategorii a troufnu si napsat, že je to vůbec nejlepší Messerschmitt 109 v měřítku 1/32. Ze stavebnice lze postavit verze E-3, E-4 a E-7, včetně tropikalizace a verzí bombardovacích. Firma HGW nabídkou doplňků podporuje pouze verzi E-7 Trop. Veškeré plastové díly mají velmi kvalitní zpracování a lícování, není třeba žádné upravování ani tmelení. Ve stavebnici nabízené detaily - motor, cockpit, zbraně - jsou naprosto dostatečné ke stavbě vynikajícího modelu. Laserem vytvořené textilní pásy umožní naprosto pohodovou práci při ztvárnění pilotní sedačky stejně jako přístrojová deska se zasklenými přístroji. Sada pozitivních nýtů umožňuje jednoduché onýtování modelu a zvýrazní realistický vzhled letounu. Markingy (obtisky) jsou provedeny nejmodernějším trendem, tedy technologií Wet Transfer. To vše umožňuje vytvoření skvěle vyhlížejícího modelu, který se velmi přibližuje skutečné předloze. Stavba tohoto modelu mě velmi zaujala.
Miloslav Hrahaň - modelář.

Přeji pohodové chvíle u stavby.
Jan Bobek - HGW

Friends, you are getting this new HGW kit to your hands. Plastic parts are from Dragon, Cyberhobby, this was an excellent choice from HGW. This model is among the best in its category and I dare write that it is the best ever Messerschmitt in 1/32 scale. The kit can be built in versions E-3, E-4 and E-7, including tropicalization and bomber versions. HGW supports the E-7 Trop in this kit only. All plastic parts have high quality workmanship and fit perfect. The details offered in the kit - engine, cockpit, weapons - are absolutely sufficient to build excellent model. Laser-fabricated belts allow you to make perfect the pilot seat, as well as the instrument panel with glazed instruments. A set of positive rivets allows easy modeling and highlighting realistic look of airplane. Markings (decals) are made by the latest trend, in Wet Transfer technology. All this makes possible to create a great looking model that is very close to the real plane. I was very impressed by the construction of this model.
Miloslav Hrahaň - modeler

I wish you a happy modeling
Jan Bobek - HGW



MAKE 2pcs
2 TEILE FERTIGEN
EFFECTUER 2 PIECES
TEE 2 KPL
GÖR 2 ST



REMOVE
ENTFERNEN
RETRIERER
SEPARARE
POISTA
AVLAGSNA



DO NOT CEMENT
NICHT KLEBEN
NE PAS COLLER
NON INCOLLARE
EILIMAA
LIMMAEJ



APPLY WET TRANSFERS
HIER WET TRANSFERS
APPLIQUER WET TRANSFERS
APPLICARE WET TRANSFERS
ASETA WET TRANSFERS
APPLICERA WET TRANSFERS



FILL HOLE
SCHLIESSEN
BOUCHER LE TROU
FORD PIENO
TÄYTÄ REIKÄ
FYLL HÅLET



PLEASE WAIT FOR A FEW MINUTES UNTIL DRY
ENIGE MINUTEN WARTEN BIS DER KLEBSTOFF GETROCKNET IST
ASPETTARE ALGUN MINUTI FINCHÉ LA COLLA È ASCIUGATA
VEKLEZ PRIBITELI OČEKAVES JARČOU NE SECHAGE
VÄNTA NÅGRA MINUTER TILLS TORR
ODOTA MUIUTTA MINUUTTI KUUNES KUUVUNUT



BE CAREFUL
HIER VORSICHT
FAIRE ATTENTION
VAROASTI
FÖRRIKTIGT



OPEN HOLE
OFFNEN
FAIRE UN TROU
FORO APERTO
AVAA REIKÄ
ÖPPNÄ HÅLET



CEMENT TOGETHER
ZUSAMMENKLEBEN
COLLER ENSEMBLE
INCOLLARE INSIEME
LIMMA YHTEEN
LIMMA IHOP



BEND
BITTE BIEGEN
PLIER S'IL VOUS PLAIT
PIEGARE
TÄTA
BOCKA



OPTIONAL
NACH BELIEBEN
FACULTATIV
FACOLTATIVO
VALINNANVARAINEN
VALBAR



INSTANT GLUE FOR METAL
METALLKLEBER
COLLA A METALLO INSTANTANEA
PER METALLO
PIKALIMAA METALLIOSIA VARTEN
SNABBLIM FÖR METALLDELAR

COLOR REFERENCE

	GS1 (H C)	AK Interactive	Mr Paint
YELLOW RLM 04	413 110	RC 267	MRP-51
FLAT WHITE	11 62	RC 004	MRP-4
STEEL	18 28	AK 476	MRP-30
BLACK GREEN RLM 70	65 18	RC 274	MRP-60
SANDY BROWN RLM 79	66 18	RC 282	MRP-68
CLEAR RED	90 47	RC 503	MRP-266
CLEAR BLUE	93 60	RC 504	MRP-267
BLACK GRAY RLM 66	416 116	RC 339	MRP-59
LIGHT BLUE RLM 78	418 118	RC 280	MRP-67
OLIVE GREEN RLM 80	420 120	RC 284	MRP-69
GRAY RLM 02	420 60	RC 052	MRP-050

	GS1 (H C)	AK Interactive	Mr Paint
SILVER	8 8	AK 3035	MRP-003
BLUE	25 34	AK 3069	MRP-238
BURNT IRON	76 61	AK 484	MRP-147
LIGHT BLUE RLM 65	67 16	RC 272	MRP-058
GREEN RLM 71	64 47	RC 275	MRP-061
RED	13 3	RC 006	MRP-041
LIGHT GULL GREY	51 41	RC 220	MRP-098
TIRE BLACK	77 137	RC 022	MRP-173
GLOSS BLACK	2 2		MRP-172
FLAT BLACK	12 33	RC 001	MRP-171

PARTS

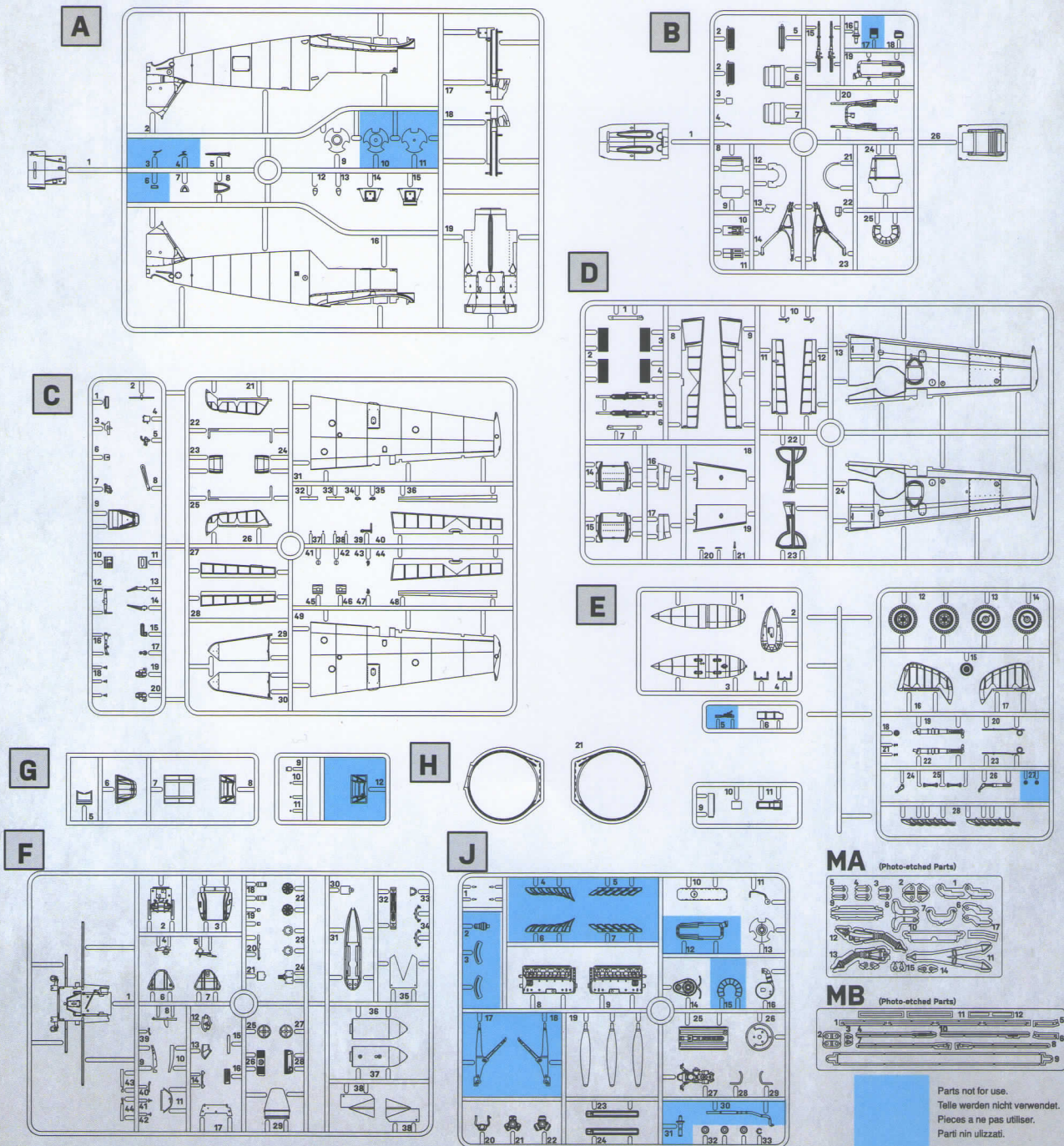

Parts not for use.
Teile werden nicht verwendet.
Pièces a ne pas utiliser.
Parti nin utilizzati.

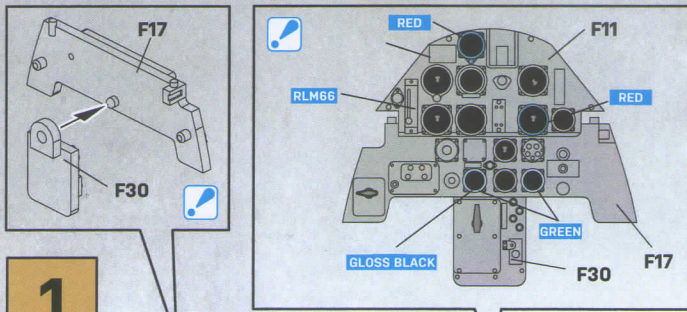

1

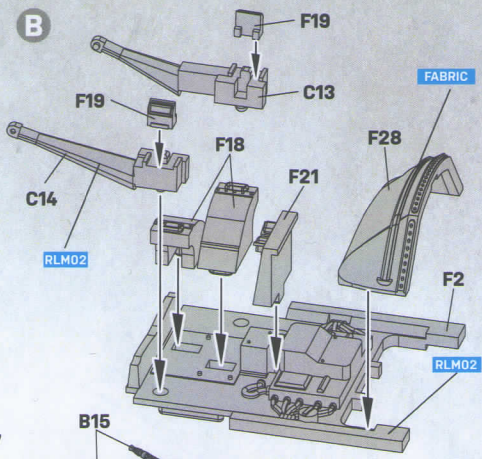

3

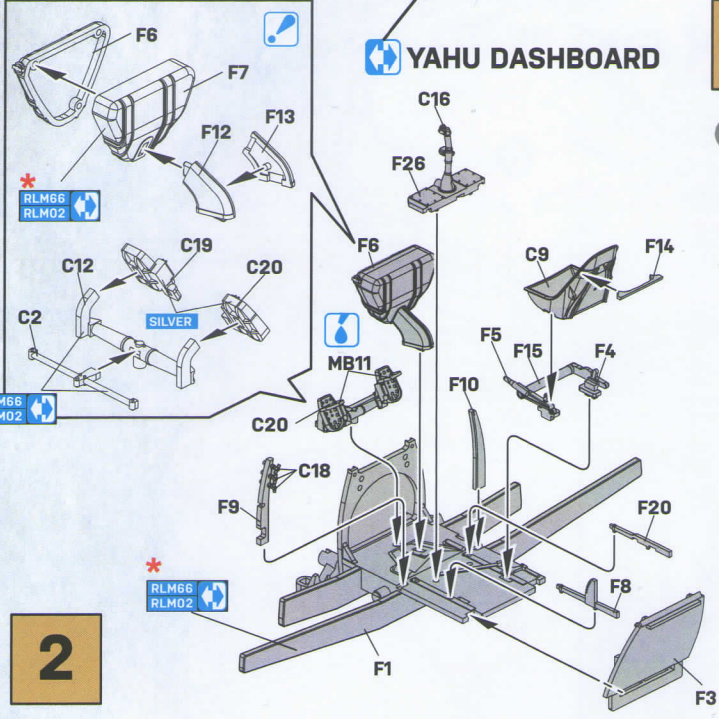

2

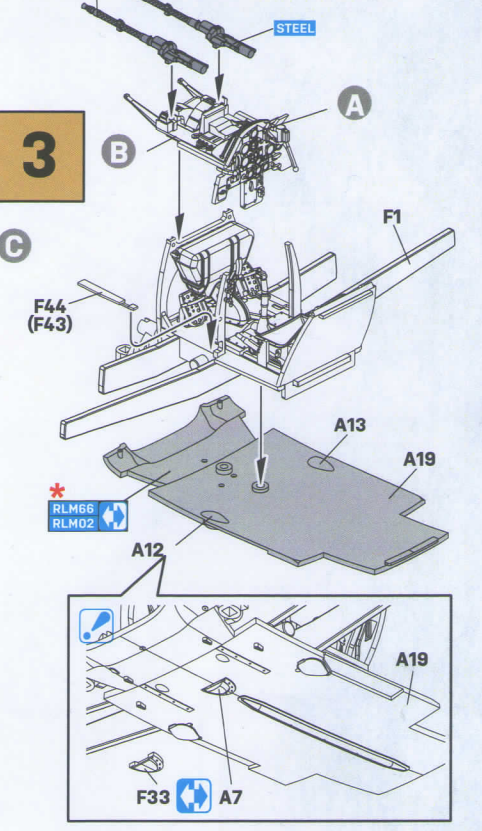

YAHU DASHBOARD

* Marking B,C, RLM 02 + RLM 66 canopy frame incl. upper fuselage.
Marking A,D,E, RLM66.

HGW FABRIC SEAT BELTS

TEXTILE PART

PHOTOETCHED PART

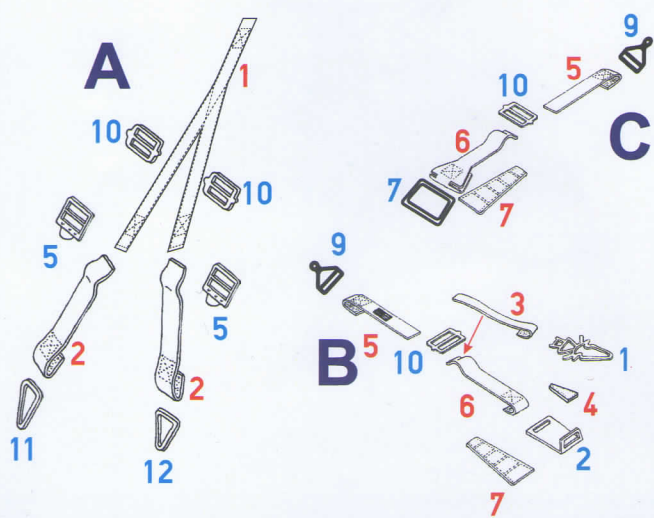

1. Take the precut textile part out of the sheet.
 2. Remove supporting paper.
 3. Crumple the belt into a little ball and need it between the fingers.
 4. Thread the belts into a little ball and need it between the fingers.
 5. Put the belts into the seat.
 6. Spray by the glossy varnish.
 7. Impregnate the belts with very diluted oil color (mix black and brown) - it will highlight the texture.
 8. Spray by matt varnish.
- After the varnish becomes dry it is possible to drybrush with light oil colour.

1/32 High Quality Detail Set
Messerschmitt Bf109E-7 Trop
132613

Messerschmitt Bf109E 132613

WARNING!
This set contains small and sharp parts. Work carefully in a ventilated and well-lit room. Safety glasses are recommended. This product is not suitable for children 14 years or younger.

WWW.HGWMODELS.CZ

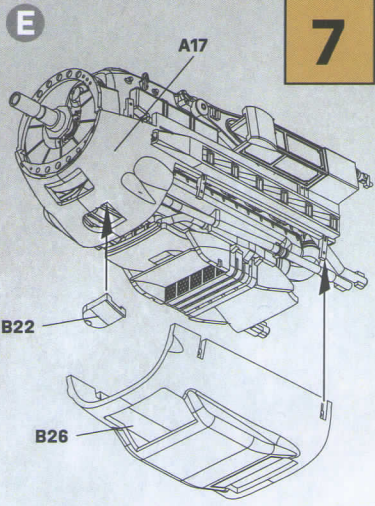

7

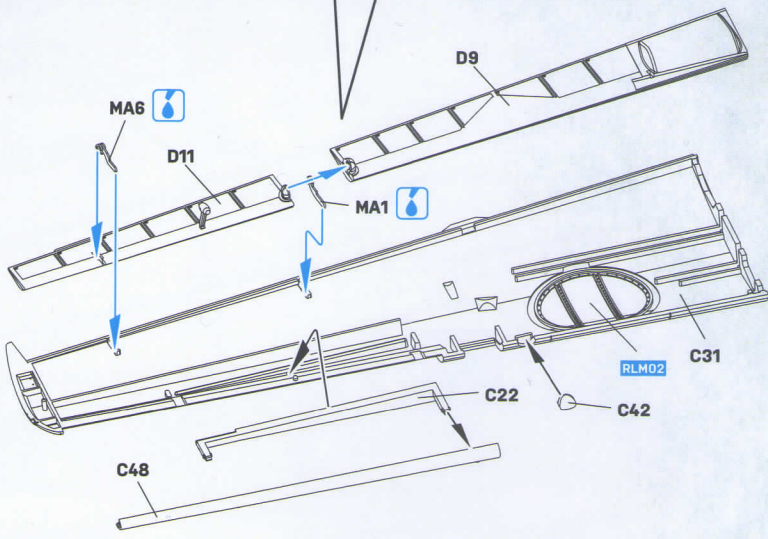
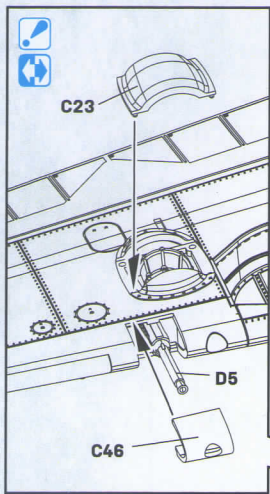
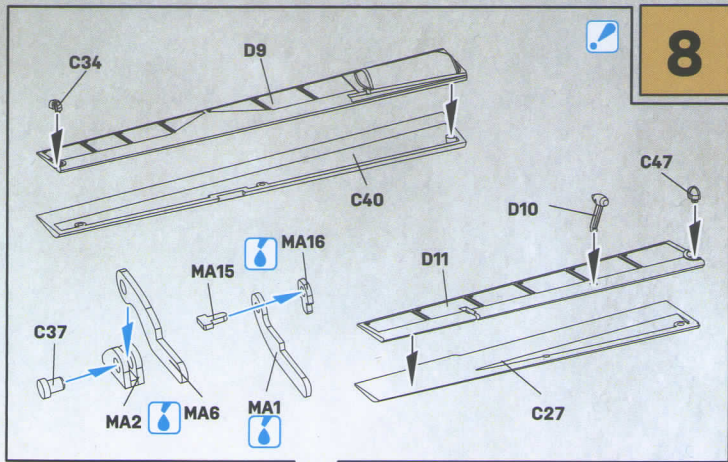

9

K

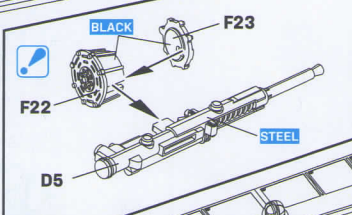
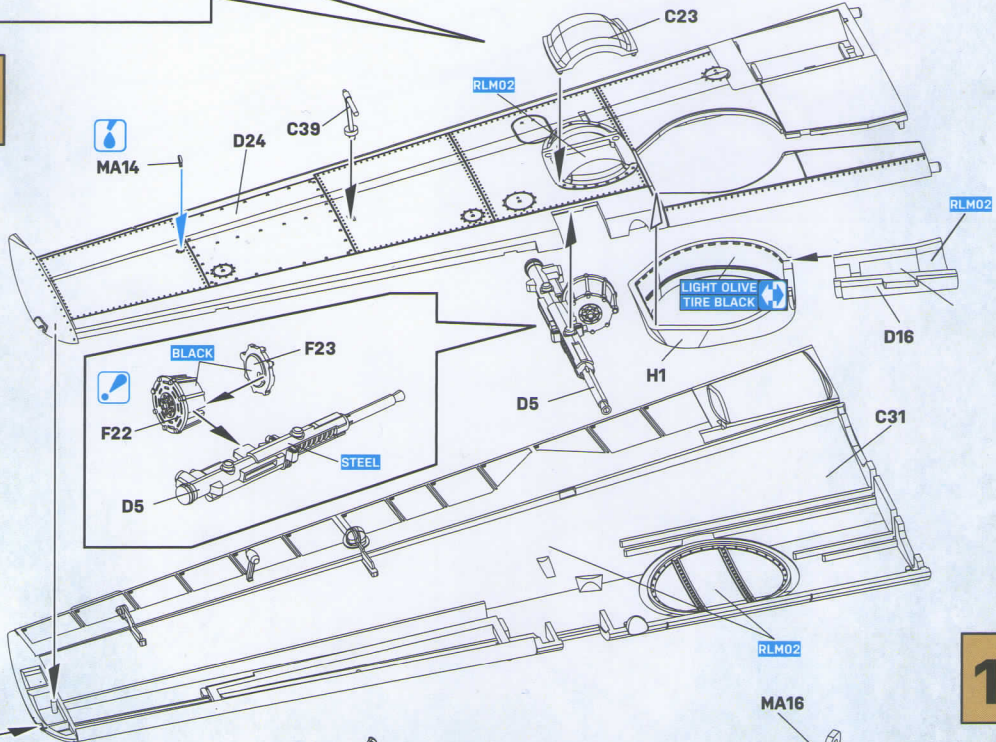

10

CLEAR RED

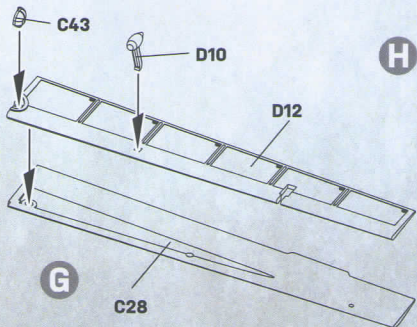
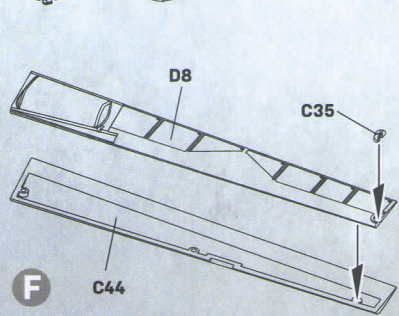

H

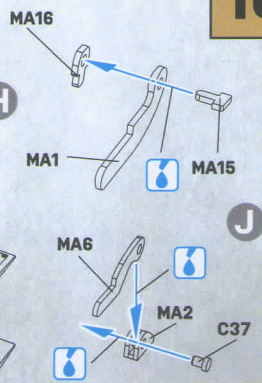

J

11

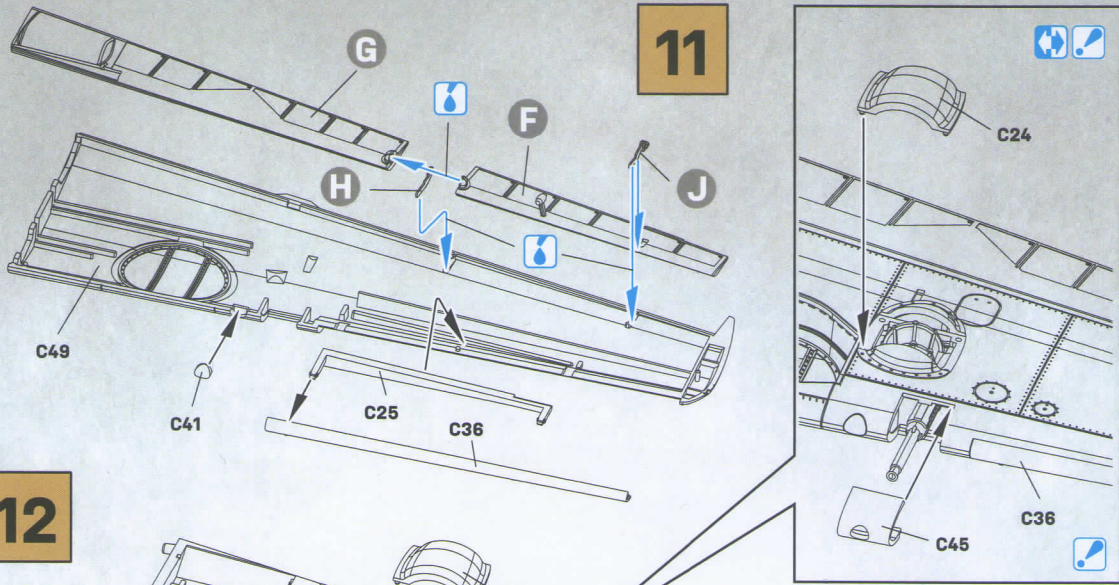

12

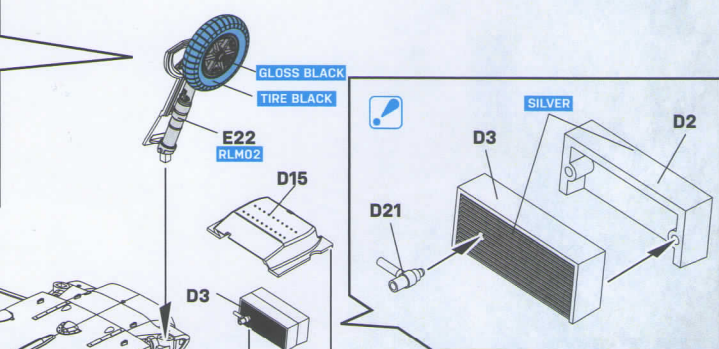
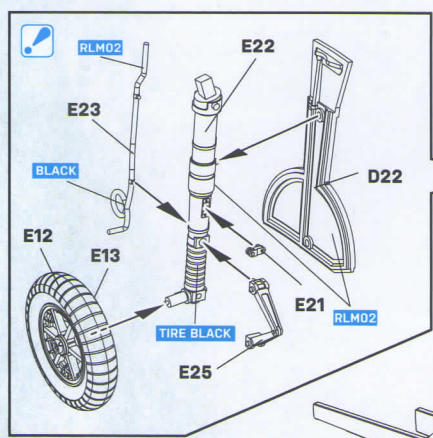
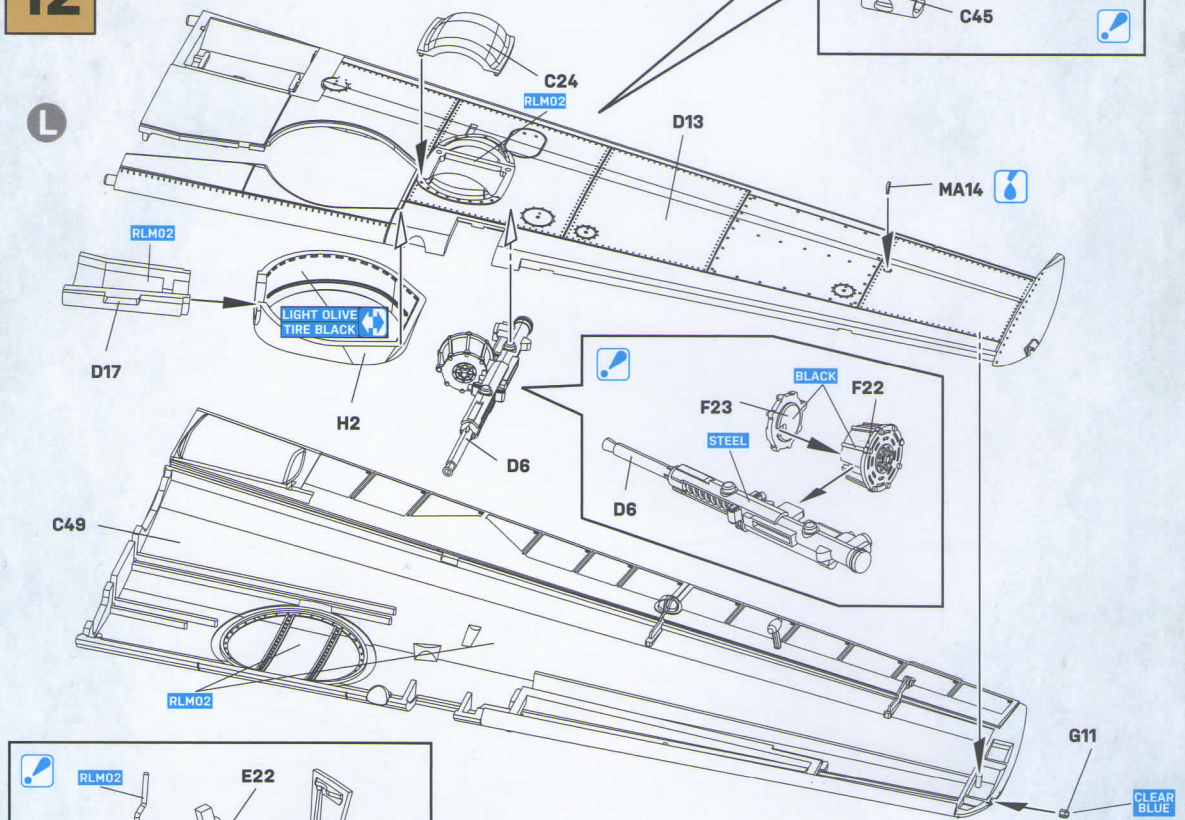

13

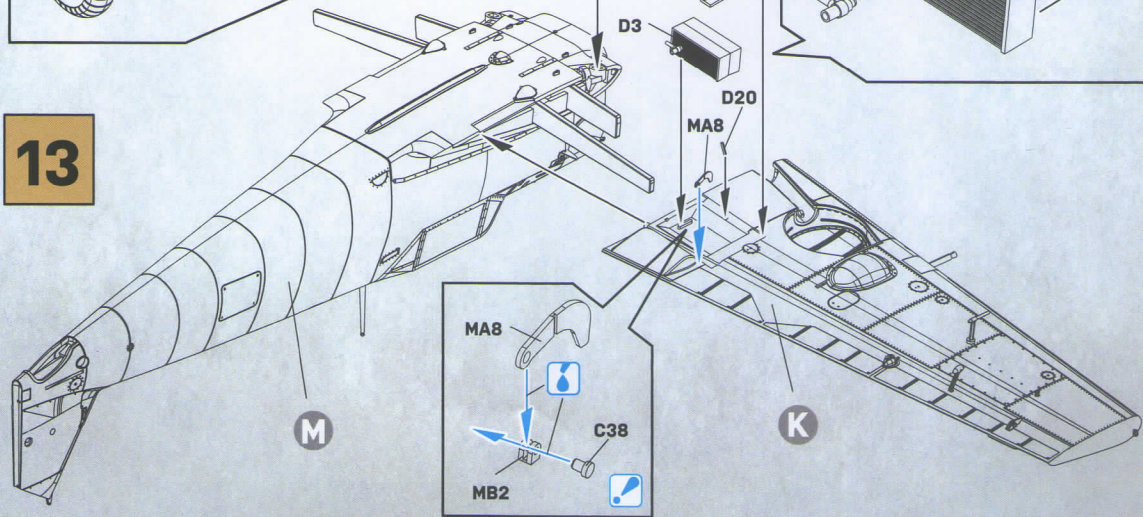

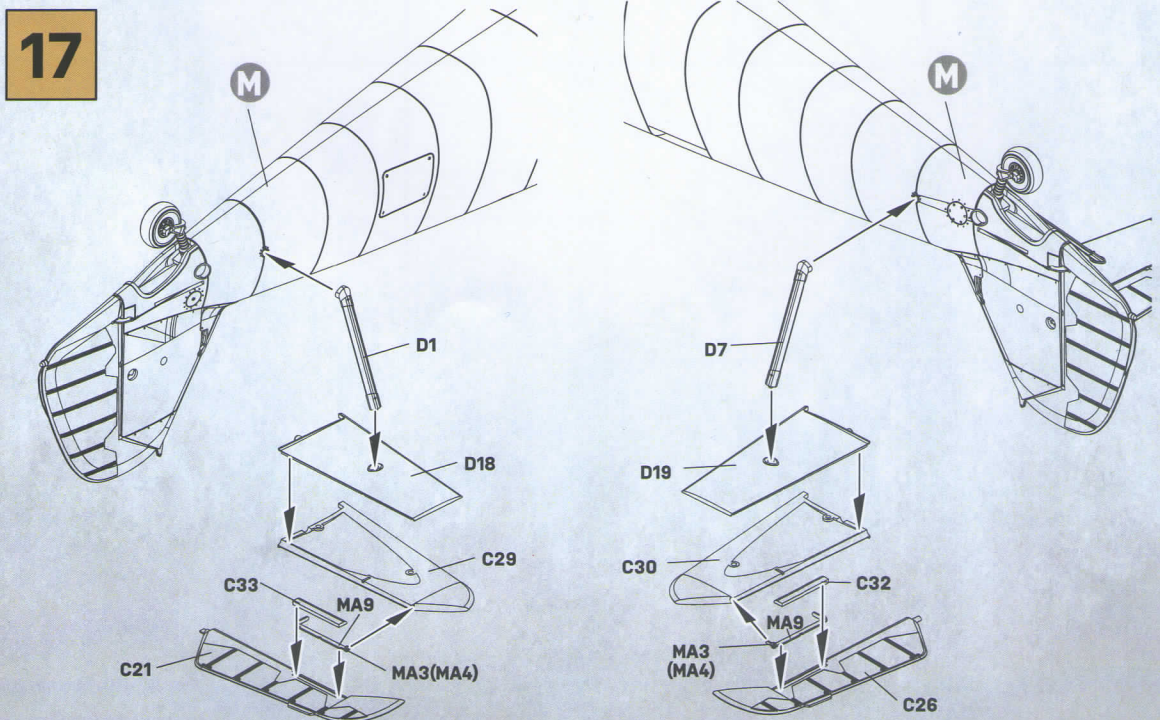
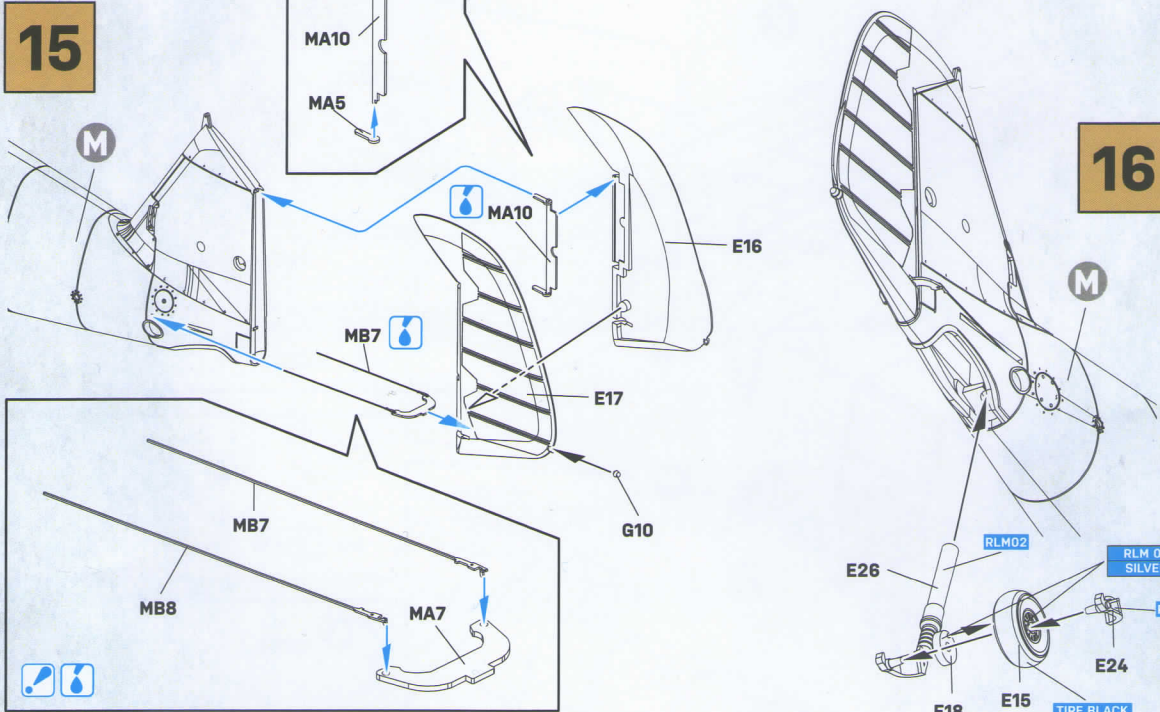
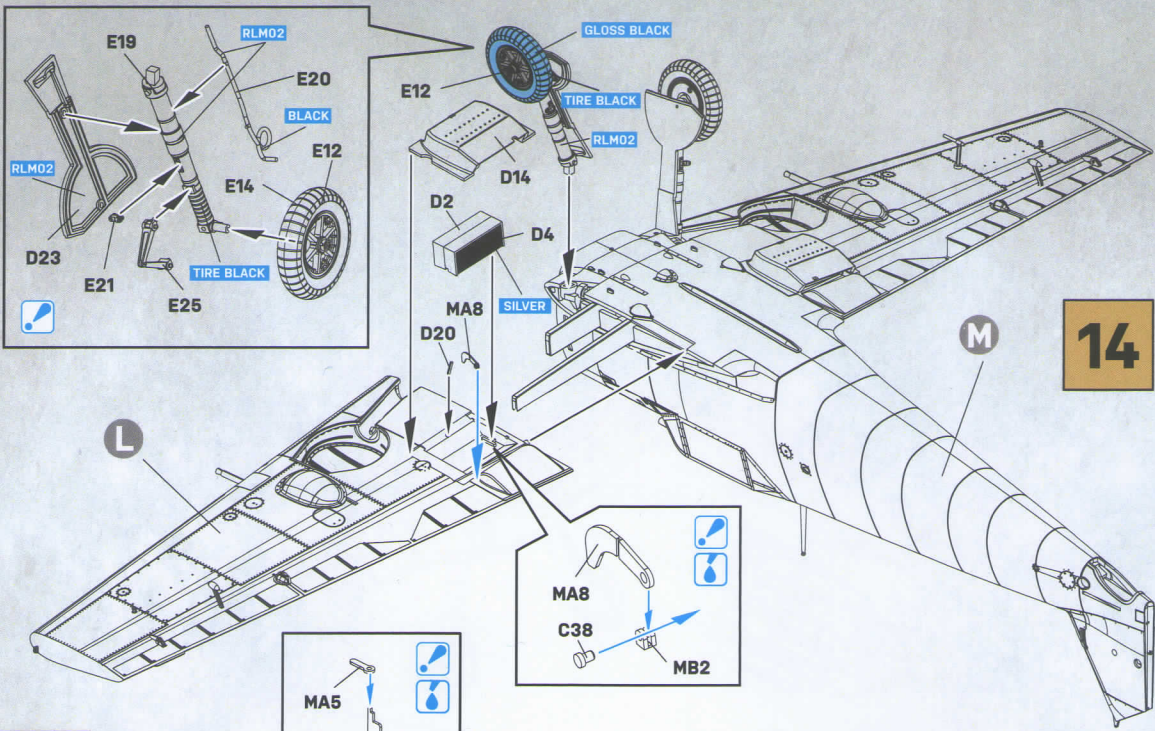

18

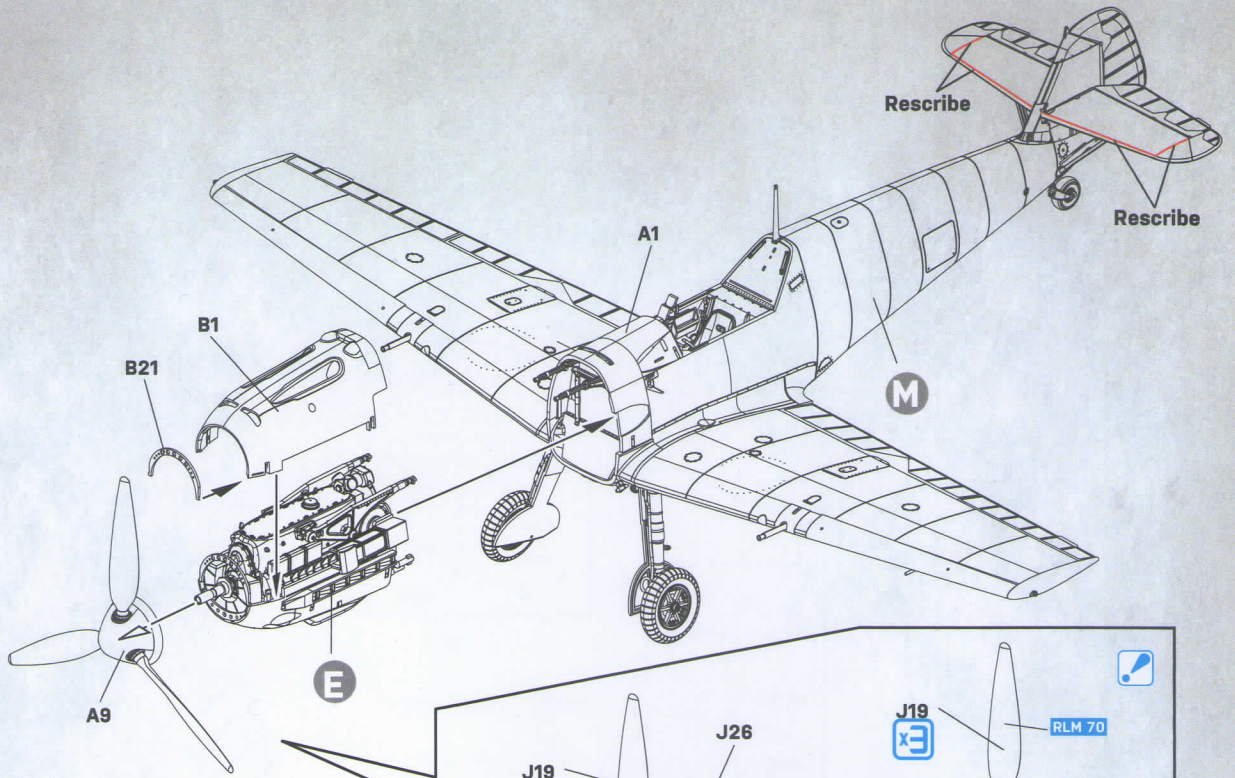

19

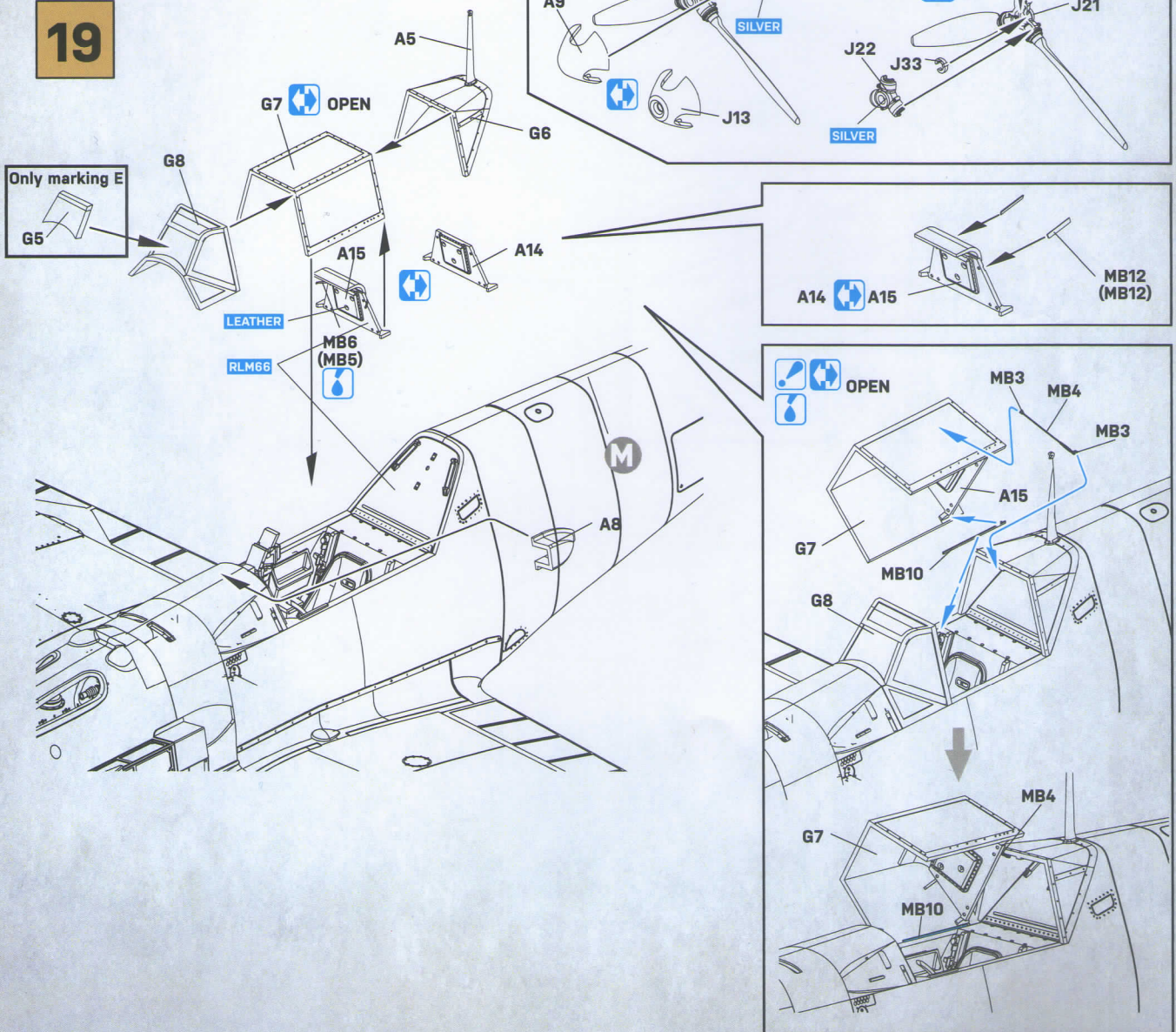

20

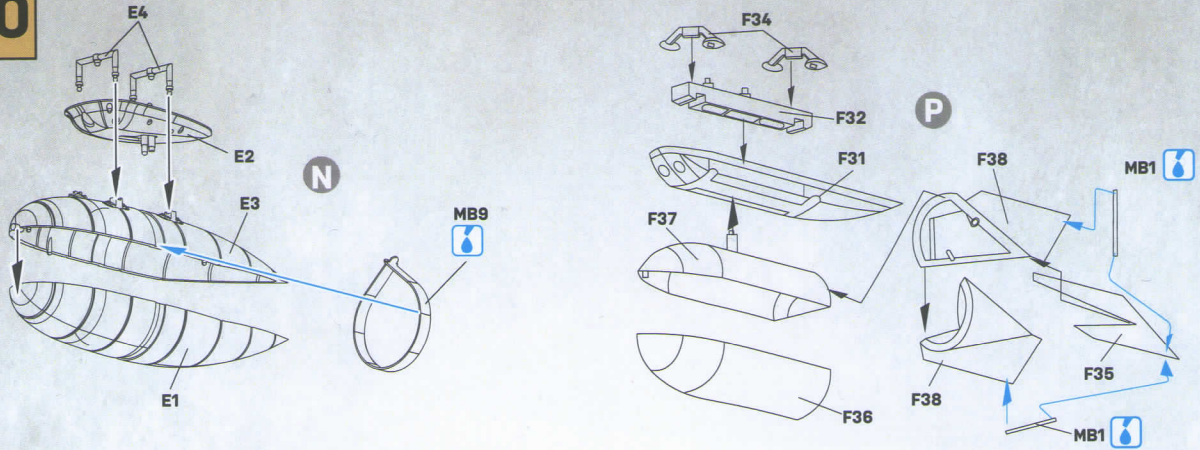

21

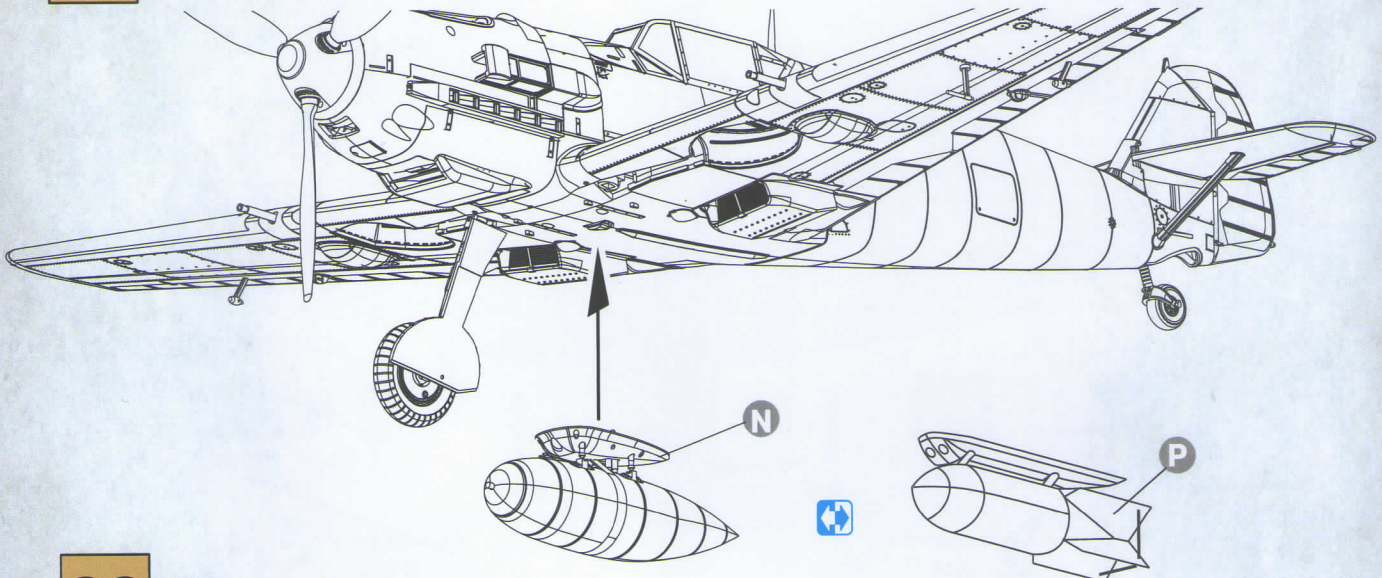

22

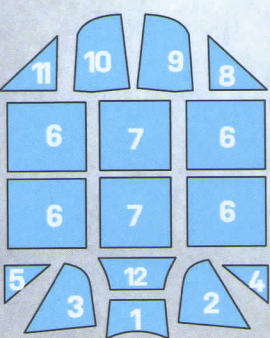
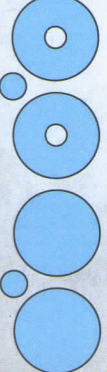
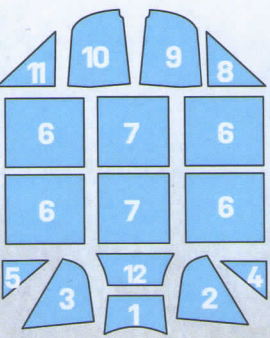
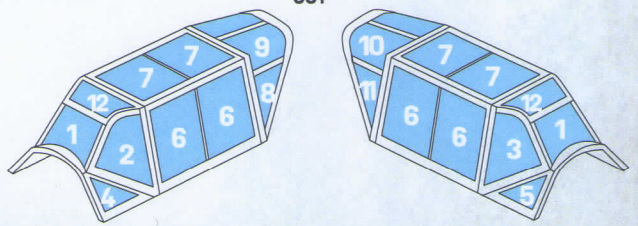
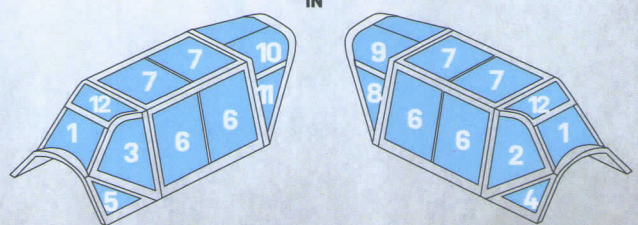

IN	WHELL MASKS	OUT	
			<p>OUT</p> 
			<p>IN</p> 

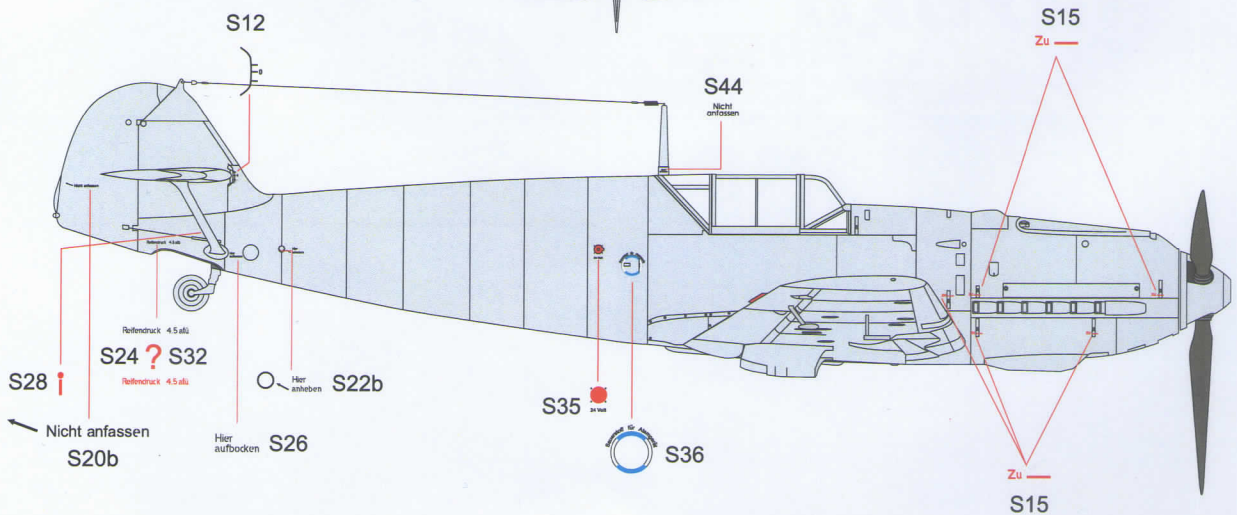
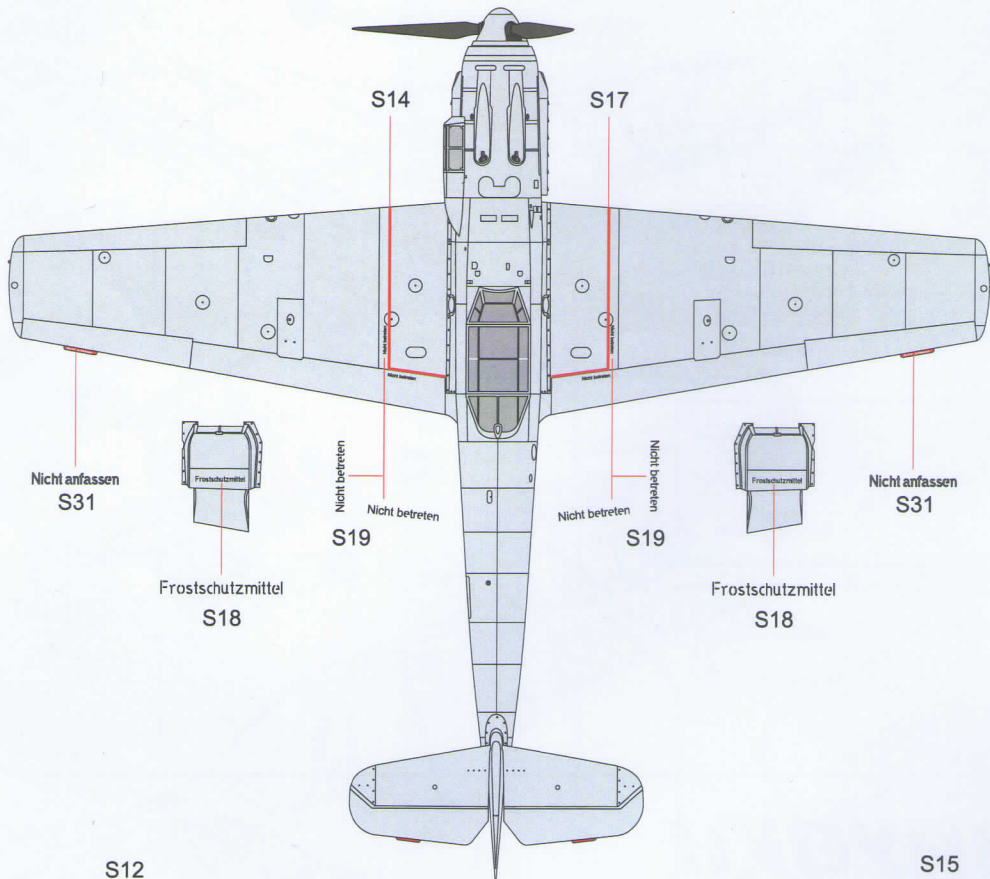
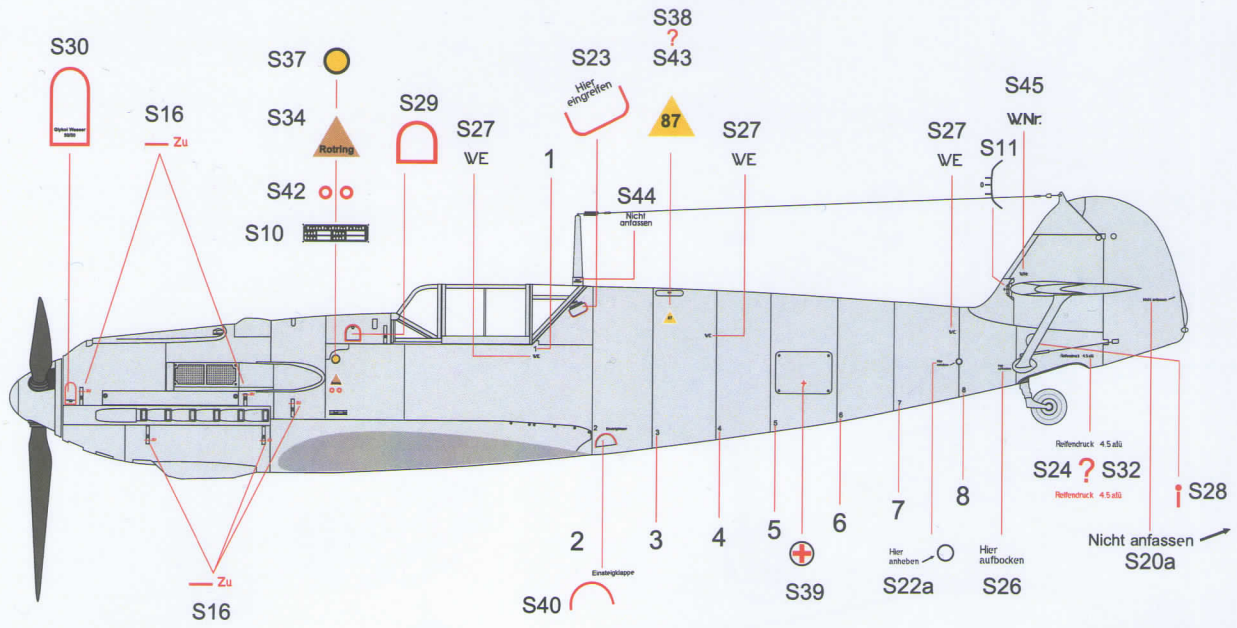

A wrecked Bf 109E-7/Trop, W.Nr.6431, pictured near Sollum in Egypt, November 1942. The aircraft crashed after being damaged in combat while covering the retreat of Rommel's troops. The aircraft had been on the strength of 8/ZG1, a Zerstorergeschwader twin-engine fighter unit, probably as an armed reconnaissance machine.

Vrak Bf 109E-7/Trop, W.Nr.6431 zachycený nedaleko Sollumu v Egyptě v listopadu 1942. Letoun nouzově přistál po poškození v souboji při krytí ústupu Rommelových vojsk, byl ve stavu 8/ZG1, Zerstorergeschwader – jednotky dvoumotorových stíhačů pravděpodobně jako ozbrojený průzkumný stroj.

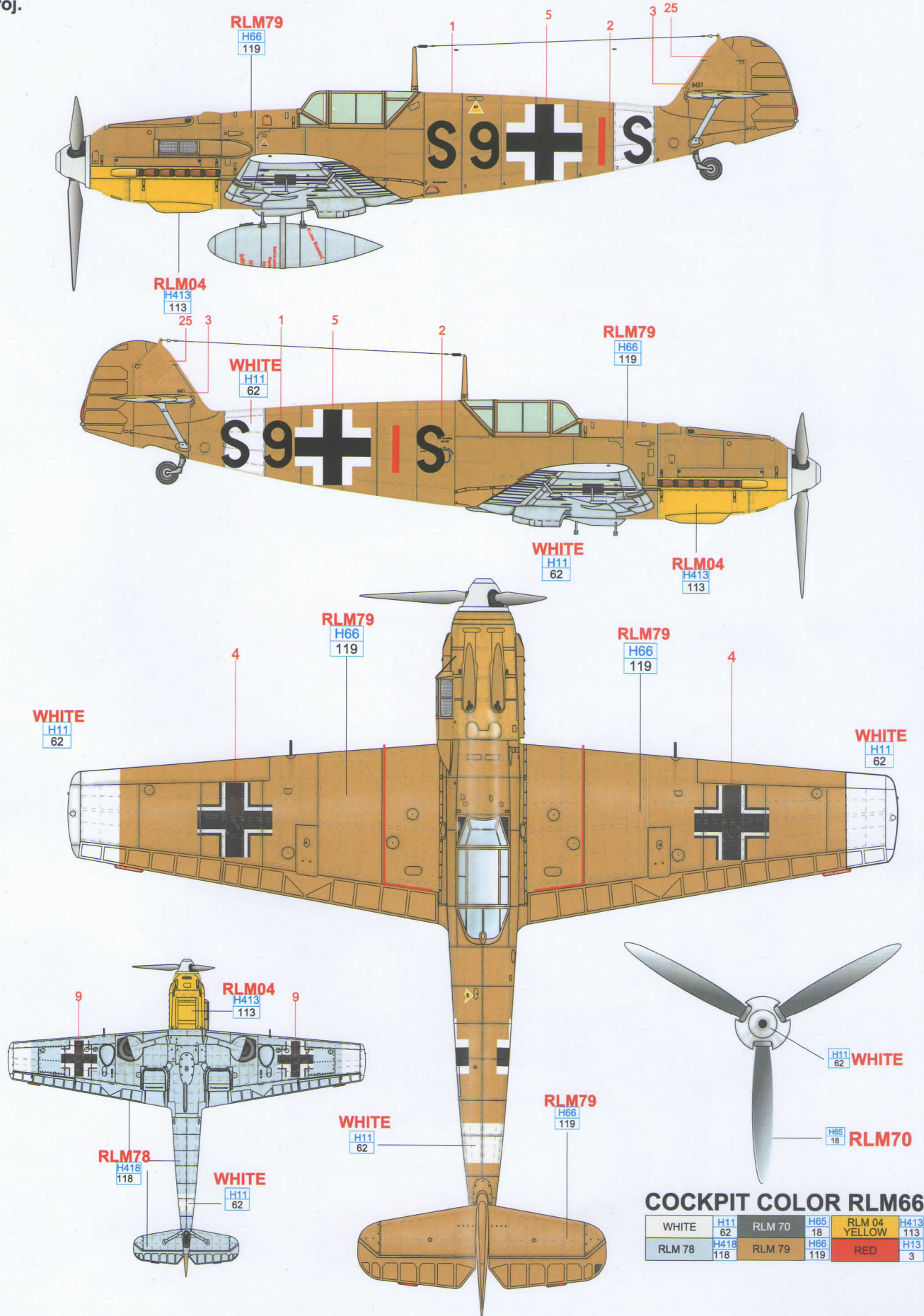

COCKPIT COLOR RLM66

WHITE	H11 62	RLM 70	H65 18	RLM 04 YELLOW	H413 113
RLM 78	H418 118	RLM 79	H66 119	RED	H13 3

Oblt. Ludwig Franzisket, Stab I/JG27, Ain-el-Gazala, Libya, June 1941

Ludwig Franzisket served as a Gruppenadjutant of I./JG 27 by December 5, 1941 when he took over the command of 1st Staffel of JG 27 from the hands of Karl-Wolfgang Redlich. He led 3rd Staffel in the period from June to August 1941 simultaneously. The evidence of pilot's function within the unit is a Black chevron and a letter „A“ on the fuselage. Twentythree Abschussbalken on the rudder show Franzisket's score as of September 9, 1941. He shoot down 24 enemy aircraft over Africa in addition to 14 victories scored previously. War end saw him a commanding officer of JG 27 with 43 kills to his score (incl. 4 four-engined bombers). He was awarded with Ritterkreuz on July 23, 1942 for 22 victories in 204 missions.

Ludwig Franzisket působil jako Gruppenadjutant I./JG 27 až do 5. prosince 1941, kdy převzal od Karla-Wolfganga Redlicha velení 1. Staffel JG 27. Během června až srpna 1941 velel také 3. Staffel. O Franzisketově zařazení svědčí černý klín s písmenem A na trupu. Třiatdvacet Abschussbalken na směrovce představuje jeho skóre k 9. září 1941. Celkem Franzisket sestřelil nad Afrikou 24 nepřátelských letadel, které přidal ke dřívějším 14 vítězstvím. Válku ukončil jako velitel JG 27 s celkovým skóre 43 sestřelů (včetně čtyř viromot - čtyřmotoráků). Byl držitelem Rytířského kříže, jímž byl vyznamenán 23. července 1942 za 22 sestřelů v 204 bojových misích.

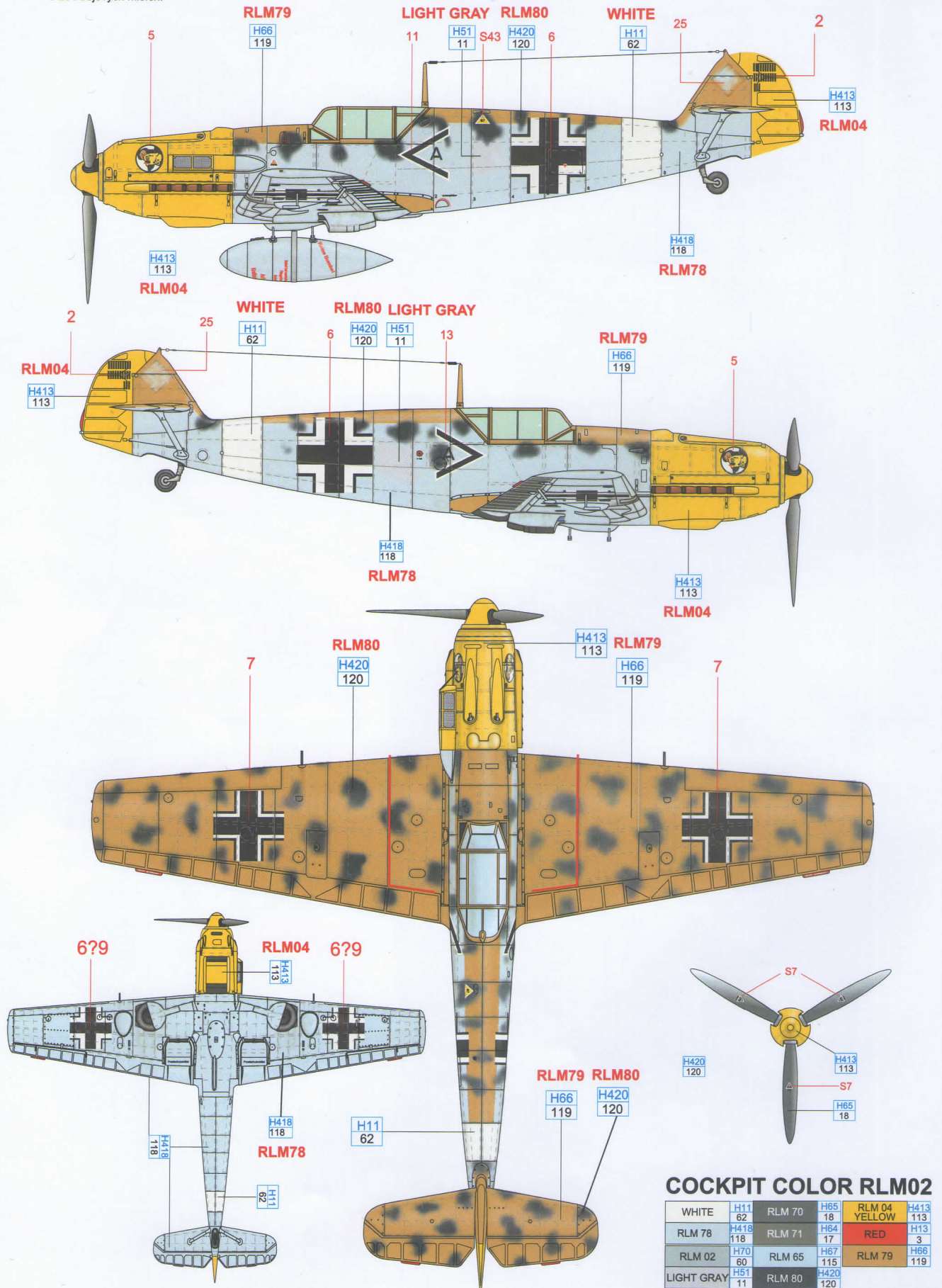

COCKPIT COLOR RLM02

WHITE	H11 62	RLM 70	H65 18	RLM 04 YELLOW	H413 113
RLM 78	H418 118	RLM 71	H64 17	RED	H13 3
RLM 02	H70 60	RLM 65	H67 115	RLM 79	H66 119
LIGHT GRAY	H51 11	RLM 80	H420 120		

I./JG27 Ain-el-Gazala, Libya 1941

One of the most interesting tropical Emilis is „Black 3“. She wore typical European camouflage scheme of RLM 71 and 02 on the upper sides and RLM 65 on the undersides. It was darkened with Dark Green (RLM 71 in all probability) stripes on the fuselage. This modification was done by the ground personnel of another unit in Europe probably as similarly camouflaged Emil was photographed in JG 3 service. Formerly all-Yellow cowling was overpainted with the same colour on its upper sides. The older fuselage number was replaced by „Black 3“ with thin Red outline.

Jedním z nejzajímavějších kamuflovaných tropických Emilů je „černá 3“. Na africký kontinent se dostal v původní tovární kamufláži tvořené nepravidelnými poli barev RLM 71 a RLM 02 na horních plochách a barvou RLM 65 na plochách bočních a spodních. Pravděpodobně ještě v Evropě bylo toto kamuflážní schéma na bocích trupu ztmaveno stříkanými pruhy tmavé barvy, zřejmě RLM 71. Tuto úpravu s velkou pravděpodobností provedli pozemní personál jiné jednotky než I./JG 27, podobně zbarvený stroj létal u JG 3. Stejným odstínem byla zřejmě přestříkána horní a boční část původně žlutého krytu motoru. Starší číselné označení na trupu bylo přestříkáno barvou RLM 02 nahrazeno černou „3“.

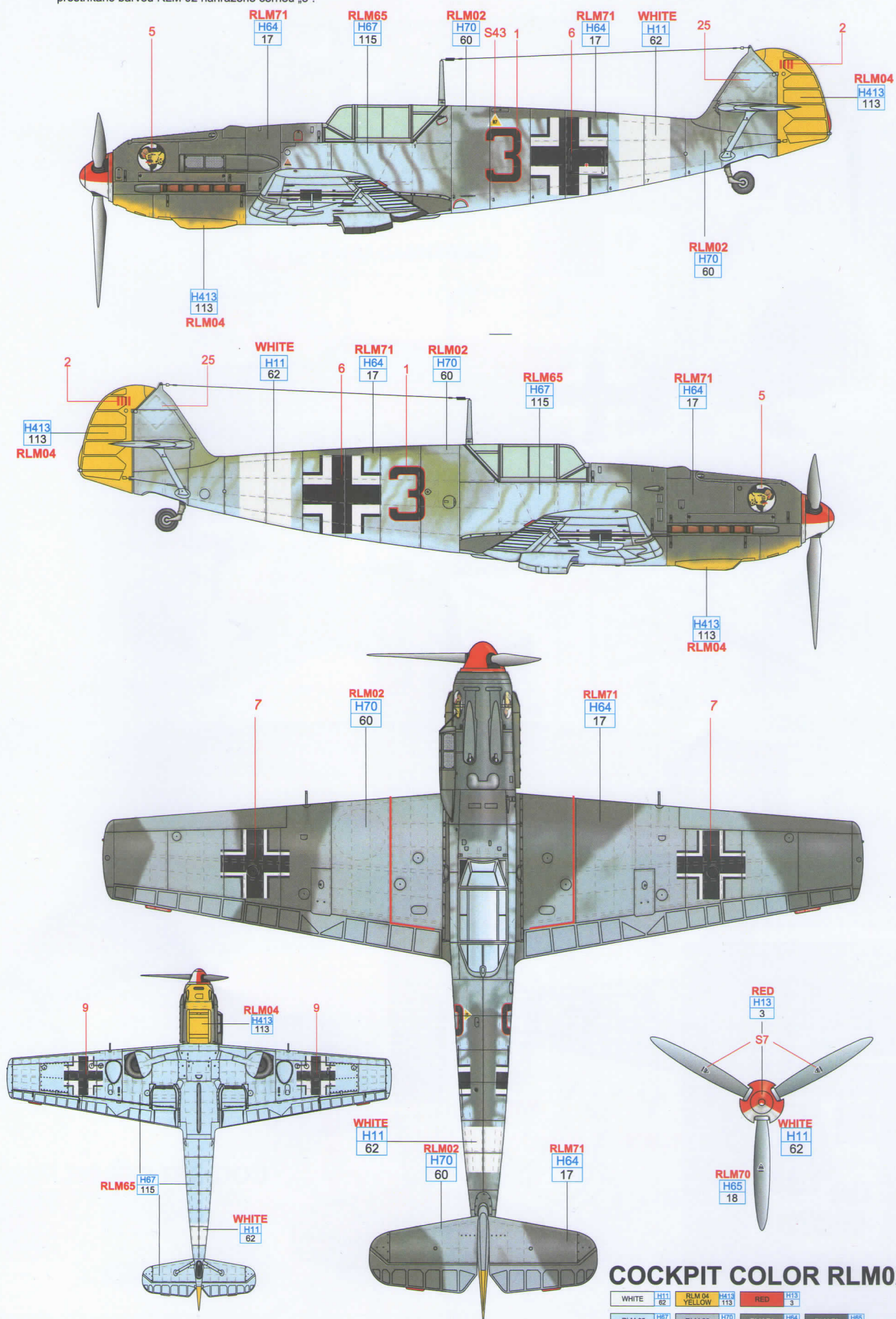

COCKPIT COLOR RLM02

WHITE	H11	62	RLM 02	H70	60	RED	H13	3
RLM 65	H67	115	RLM 04	H413	113	RLM 71	H64	17
			RLM 70	H65	18			

8.ZG1, El Daba, Libya 1942

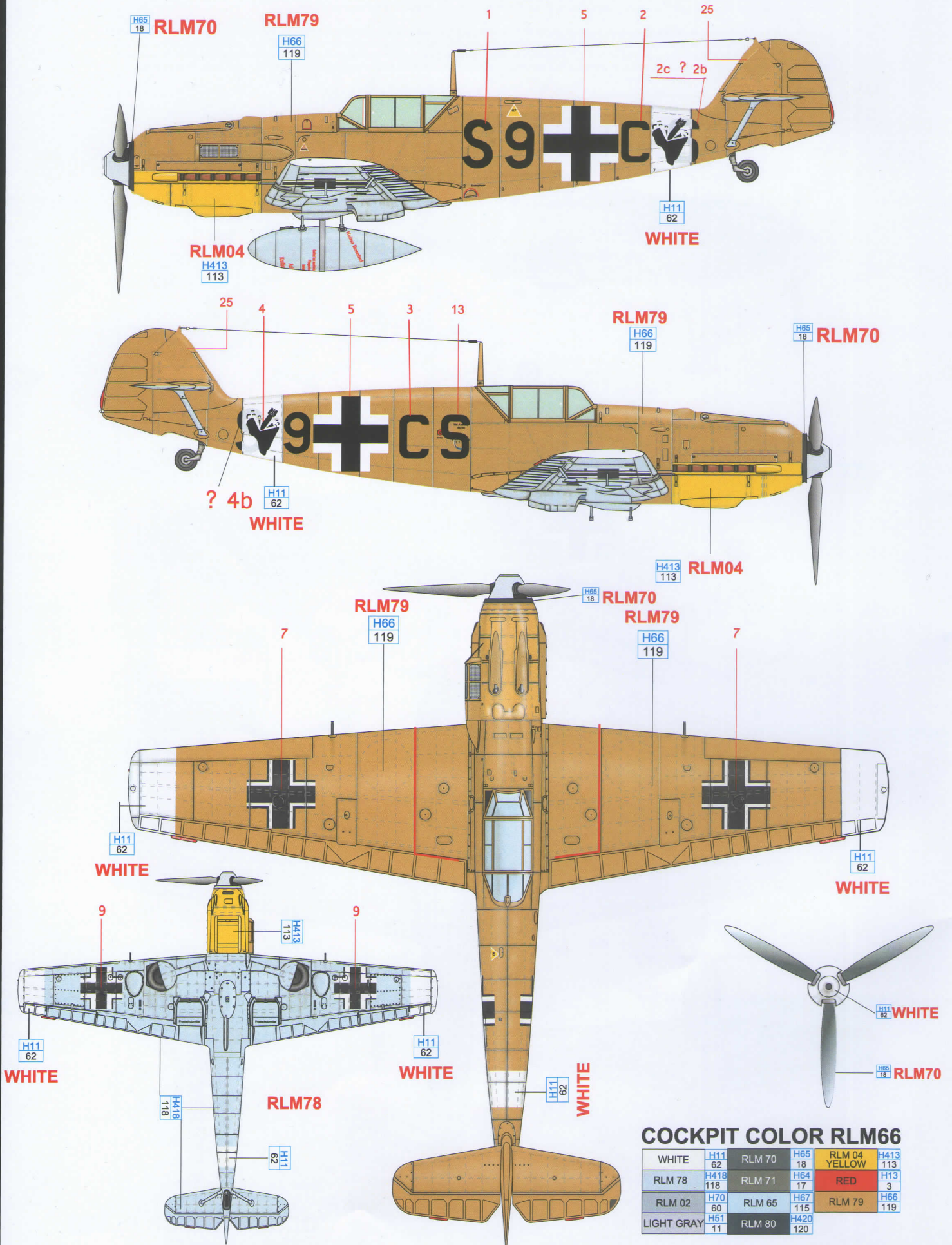

COCKPIT COLOR RLM66

WHITE	H11 62	RLM 70	H65 18	RLM 04 YELLOW	H413 113
RLM 78	H418 118	RLM 71	H64 17	RED	H13 3
RLM 02	H70 60	RLM 65	H67 115	RLM 79	H66 119
LIGHT GRAY	H51 11	RLM 80	H420 120		

7.ZG1, W.Nr 4964, El Alamein, Libya, August 1942 Uffz., Hans Sennholz

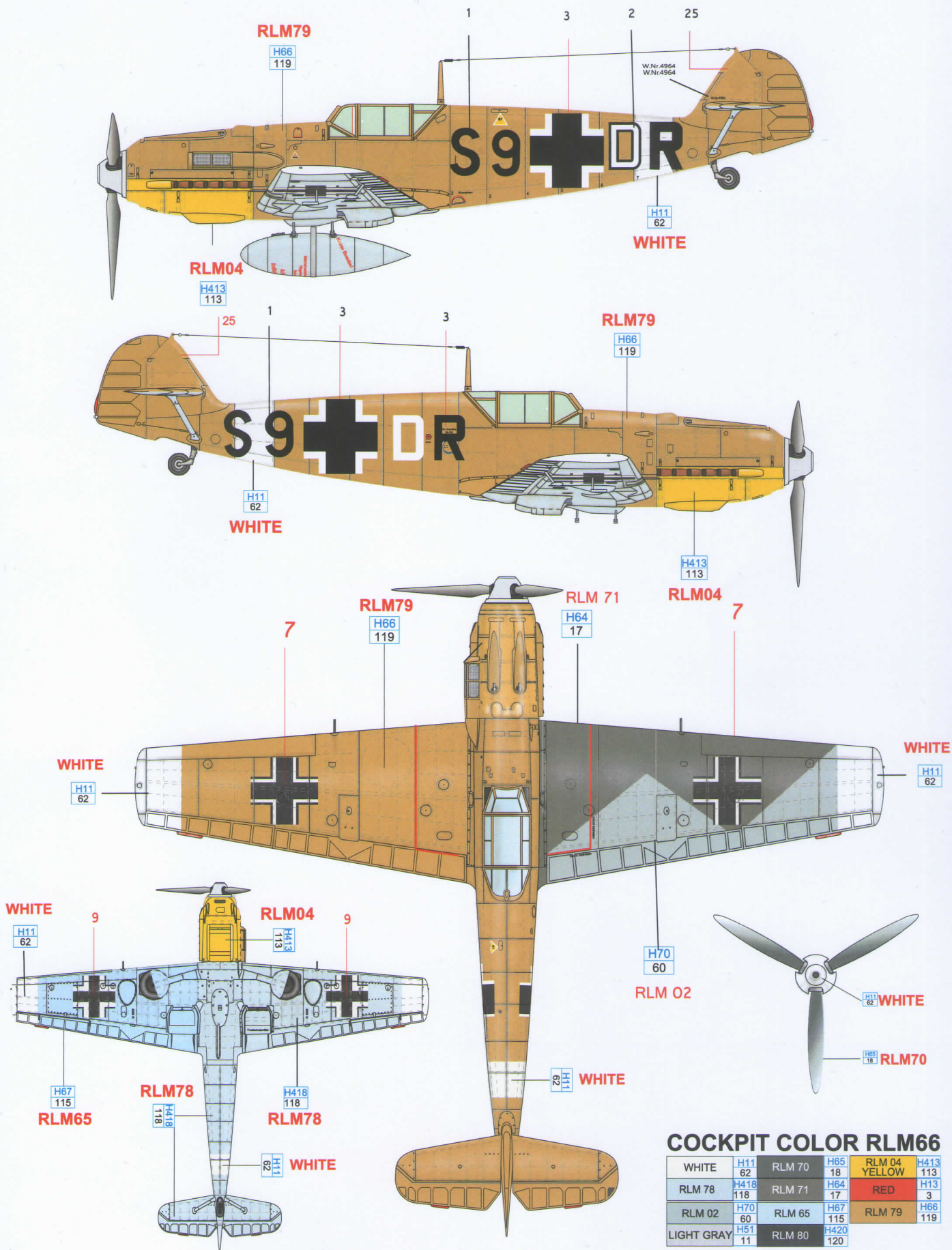

COCKPIT COLOR RLM66

WHITE	H11 62	RLM 70	H65 18	RLM 04 YELLOW	H413 113
RLM 78	H418 118	RLM 71	H64 17	RED	H13 3
RLM 02	H70 60	RLM 65	H67 115	RLM 79	H66 119
LIGHT GRAY	H51 11	RLM 80	H420 120		



HGWmodels.cz
info@hgwmodels.cz