

31820



3-in1 Ford LNT

**SNOW PLOW**

**DUMP TRUCK & SEMI TRACTOR**



099-31820

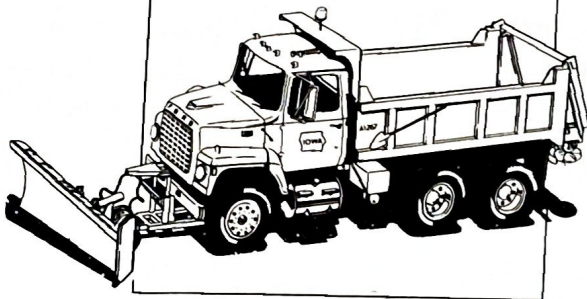

**A**t 3 a.m. on a January morning, the world is asleep. A peaceful snow floats gently through the frozen air burying buildings, vehicles and roads in foot-deep drifts. Nothing moves.

Away from the city, the highway has disappeared under a heavy winter blanket. Roads are impassable. The snow has taken on an air of permanence, but it must be moved.

In the garage where the snowplows are kept, the great clattering diesel engines are thundering to life. Plows are adjusted and dump trucks are filled with road salt. Bleary-eyed drivers climb into cabs and throw their Fords into gear. Rolling down the highway, headlights gleaming off the white, the plows slam into drifts with tons of force, sending clouds of powder off to one side. The Meyer spreader releases a steady stream of salt out the tailgate to eliminate any further problems. Early risers begin their drive to work on a clear road.

when commercial roadsters and delivery vans, based on the Model T passenger car, were first offered for sale. By the middle of the 1930s, Ford had already put over 3 million trucks on the road.

In 1970, the L-line of Ford trucks was started. L is short for Louisville, the city in Kentucky that is home to the Ford truck plant. When it was built, this plant was the largest in the world. It produces a range of medium and heavy-duty trucks, filling the gap between the F-series and the W-range. After fifteen years of production, the L-line is still a bestseller, offering a choice of more than 650 models.

The heavy-duty construction and tandem axle of the Ford LN make it durable enough to take the brutal punishment handed out to a dump truck. In this role, the Ford LN can be seen at highway construction sites, working together with loaders, literally moving mountains of earth to create overpasses and on-ramps. In the quarries, power shovels fill the trucks with rock to be hauled to the crushers. At mining sites they carry ore and at salt flats they bring raw salt to the processing plants. The versatile LN can also be used to pull cargo on the nation's highways. Geared low enough to pull tons up the side of a mountain, this workhorse is also right at home barreling down the flat.

**FORD LNT 8000 Chassis**  
**Engine:** Cat V8 Diesel  
**Brakes:** Air  
**Clutch:** 14" diameter — 1 plate  
**Transmission:** 5 speed  
**Wheels:** Cast spoke — 10 hole disc  
**Tires:** Goodyear tubeless radial

**Valk 84 Snow Plow**  
**Overall width:** 12'3"  
**Height of Nose End:** 29"  
**Height of Discharge End:** 49"  
**Weight of Plow:** 1,390 lbs.

**Meyer UTG 600 Salt Spreader**  
**Type:** Under tailgate  
**Width:** 96"  
**Hopper:** 7 gauge  
**Auger:** Dual 4" flights  
**Bearings:** Self-aligning, sealed, dust proof, zerkl fittings

**Heil Dump Box**  
**Type:** HPT-53 Series  
**Body Length:** 12'  
**Hoist:** Model 53-110  
**Weight:** 790 lbs.  
**Dump Angle:** 52 degrees

### Average Yearly Snowfalls

Helena, Montana	48.8 inches
Fargo, North Dakota	35.4 inches
New York City, New York	29.3 inches
Des Moines, Iowa	33.4 inches
Portland, Maine	74.5 inches

Based on snowfalls from 1939 to 1978.

**Please read through the instructions before building your kit.** Get a general feel for the assembly sequence and compare the kit parts with the illustrations.

**Note** that the kit is assembled by building up sub-assemblies which are then put together to form the final assembly. This will allow cement and paint to dry on one assembly while you work on the next assembly.

**We recommend** that you test fit parts together before applying cement to check for fit and actual location.

**Always trim** the parts off the trees with a sharp hobby knife. Pulling them off by hand will result in either an extra bit of plastic or hole on part. Also a little trimming or filing will often make a good fit a perfect fit.

When assembling plated parts you should carefully scrape off the contact areas of the plated parts for a good bond, this also holds true for painted parts, plastic cement cannot go "through" paint or plating. Be careful not to get cement on plated and painted surfaces other than the glue surface as it will discolor these surfaces. We recommend using paint and cement specifically labeled for styrene plastic.

**Be sure** to read all labels and warnings on cement and paint containers. These products should only be used in well ventilated areas.

### Additional Building Tips

For the best possible finish you should paint your model, even though it is molded in color. Paint will also make the decals look better as they stick better to a painted surface.

For the most authentic looking scale model we recommend that you **always use good tools** such as a good hobby knife with a sharp blade, jewelers or hobby files, a good artists brush (00 size), small tweezers and clamps to hold small parts.

In examining your parts you will note that all parts have a small line around them. This results from where the mold halves meet during the molding process and is called the parting line. The body will have several parting lines around it. To prepare your non-plated parts for painting remove the parting line by using the edge of your hobby knife or small file. After cementing parts together the glue joint can be removed the same way but be sure the cement is dry first.

Sanding larger parts with fine (600 Emery) sandpaper will prepare the surface for painting by providing a "tooth" on the surface to hold the paint. This will also help to blend contours, especially on the body.

**Be sure** to wash your parts before painting. This removes the mold release agents that may be used in manufacturing, oil from your fingers and sanding residue. Use a mild solution of dishwashing detergent and water, rinse with lukewarm water and air dry.

A primer paint can be used to paint all parts before using a color paint. When using spray paint **apply several light coats**, allowing drying time between coats. This will give you an even finish and eliminate peeling and drips which result from trying to paint one heavy coat. Paint the various sub-assemblies as a unit such as engine with all non-plated parts assembled. Hand paint final details such as instrument faces, fan belts, seat belts, etc. after painting your base color.

If you are painting a two tone paint scheme, paint the lighter color first, let it dry thoroughly, then mask with a frosted clear tape for your second color.

It is useful to paint all the window moldings before cementing windows into body. Chrome trim marker lights and other detailing may be painted after final assembly to avoid excessive handling and potential smearing of these details.

**It is a good idea** to test-fit the body over the completed chassis before painting the body. This will give you an idea on cementing locations, possible fit problems and how to handle the body to avoid harming finish during final assembly.

To give the body an automotive luster it should be painted with several light color coats followed by a final gloss coat. (Be sure to let paint dry thoroughly between coats.) The final gloss coat of paint may be rubbed out (after it has dried for several days) by using a soft automotive paste wax (just a little) and a very soft rag to apply it. An alternative method is to use a coat of "clear" paint over the final color coat to add sheen and luster to your model.

**As you gain experience** you may wish to incorporate your own details such as engine wiring, brake cables, actual paint schemes and other extra items. We recommend you acquire brochures, magazine articles, actual photos, etc. to make your kit a more individualized scale model of the real thing. Which is all a part of the fascinating hobby of scale kit building.



Use a good sharp model knife to trim and detach plastic parts. Some parts will appear to have extra "tabs" on them — cut these off.



Tweezers are handy for holding very tiny parts when you glue them in place or when you are painting them.

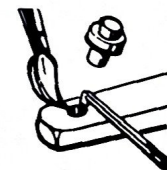

We recommend the use of liquid poly styrene cement. Apply with a fine brush and toothpick. Do not use too much glue — a sloppy job will result.



## ENGINE ASSEMBLY

- Cement both halves of the ENGINE BLOCKS (18 and 21) together.
- Cement the VALLEY COVER (4), and both CYLINDER HEADS (9 and 12) to the top of the ENGINE.
- Cement the FUEL INJECTOR (514) to the VALLEY COVER.
- Cement the OIL COOLER (10) and one of the two ENGINE MOUNTS (36) to the left ENGINE BLOCK.
- Cement both OIL FILTERS (13) to the OIL COOLER.

Paint all engine parts BLUE unless otherwise indicated.  
ENGINE MOUNT - FRAME COLOR  
OIL FILTERS - WHITE

Fig. 1

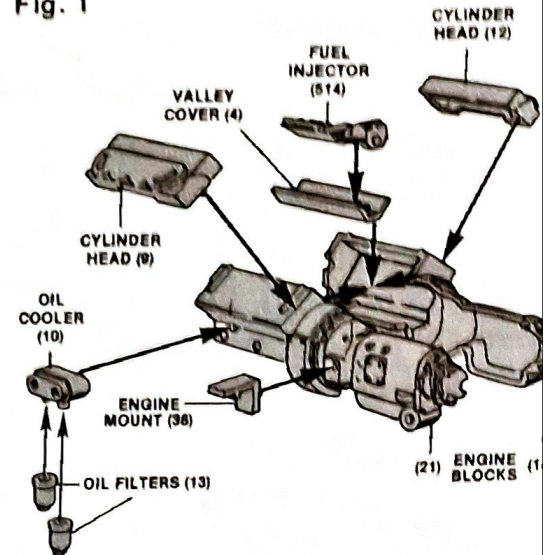
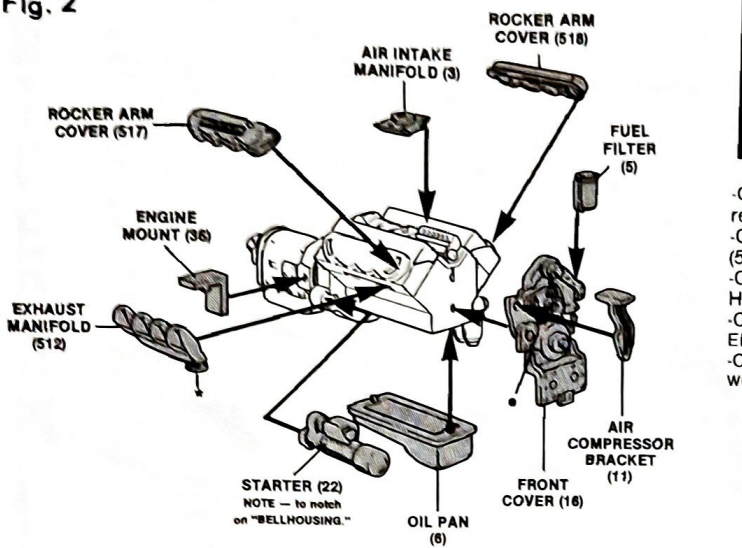

Fig. 2



- Cement the OIL PAN (6), STARTER (22), FRONT COVER (16) and remaining ENGINE MOUNT (36) to the ENGINE.
- Cement the AIR COMPRESSOR BRACKET (11) and the FUEL FILTER (5) to the FRONT COVER.
- Cement both ROCKER ARM COVERS (517 and 518) to the CYLINDER HEADS.
- Cement one of the EXHAUST MANIFOLDS (512) to right side of ENGINE as shown.
- Cement the AIR INTAKE MANIFOLD (3) to the top of the ENGINE between the CYLINDER HEADS as shown.

ENGINE MOUNT - FRAME COLOR  
FUEL FILTER - RED

\* EXHAUST PIPE / MUFFLER Location; see page nine.

• RADIATOR HOSE location; see page nine.

## FOUR

- Cement the EXHAUST MANIFOLD (513) to the CYLINDER HEAD as shown.
- Cement both halves of the POWER STEERING PUMP (8 and 7), the FAN (20), and the ALTERNATOR (506) to the PULLEY ASSEMBLY (15).
- Cement the PULLEY ASSEMBLY to the FRONT COVER.
- Cement the AIR COMPRESSOR (527) to the AIR COMPRESSOR BRACKET and the PULLEY ASSEMBLY.
- Cement the PCV VALVE (14) to the AIR INTAKE MANIFOLD.

FAN - BLACK  
PULLEY ASSEMBLY - BELTS - BLACK, PULLEYS - BLUE

Fig. 3

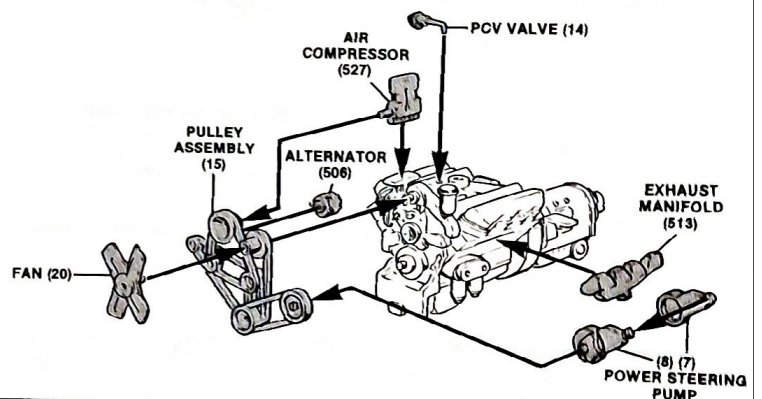

## TIRE ASSEMBLY

- Cement a WHEEL FLANGE (522) and a FRONT RIM (554) together, trapping a TIRE in between. (Assemble two sets at this time.)

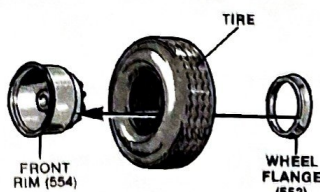

## TIRE ASSEMBLY

- Cement both halves of the REAR HUB (525 and 502) together as shown.
- Cement two WHEEL FLANGES (552) to the REAR RIMS (501 and 500) as shown trapping a TIRE between the FLANGES and RIMS.
- Slip the REAR HUB through the RIMS as shown. (Assemble four sets.)

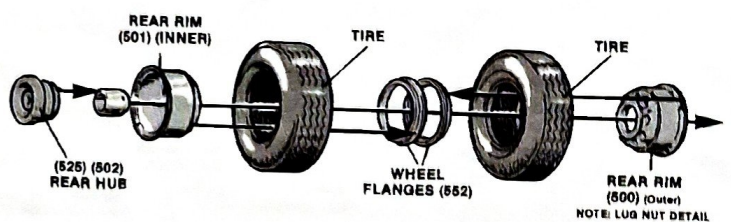



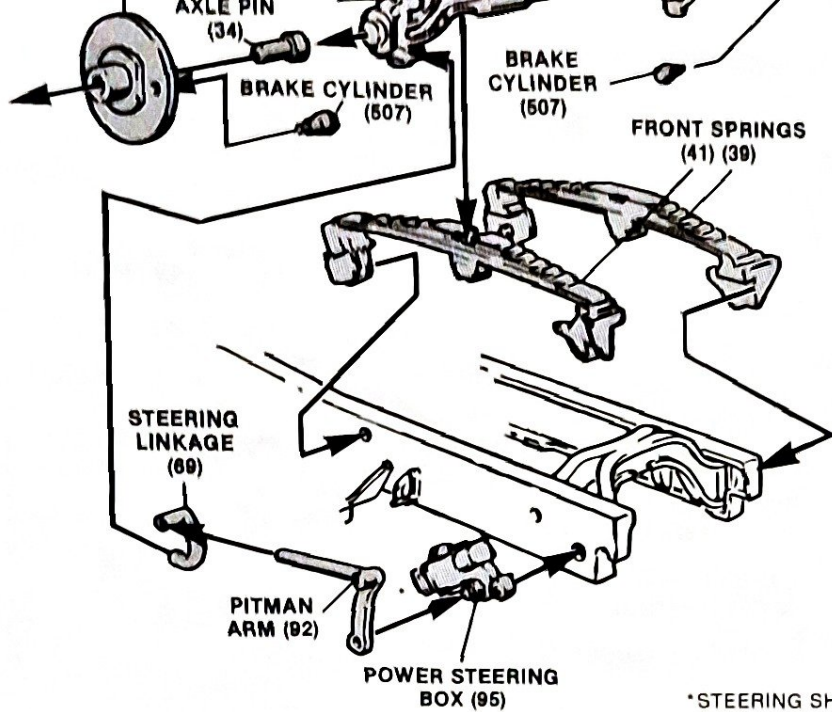

**Fig. 2**

- Cement both FRONT SPRINGS (41 and 39) and the POWER STEERING BOX (95) to the FRAME as shown.
- Cement the TIE ROD (68) to the FRONT AXLE (70) as shown.
- Cement the FRONT AXLE to the FRONT SPRINGS.
- Cement the PITMAN ARM (92) to the POWER STEERING BOX.
- Cement the STEERING LINK (69) to the PITMAN ARM and FRONT AXLE.
- Cement both BRAKE CYLINDERS (507) to the FRONT BACKING PLATES (54).
- Slip the AXLE PINS (34) through the BACKING PLATES and carefully cement the PIN to the FRONT WHEEL. Do not get cement on the BACKING PLATE.
- Cement the BACKING PLATES to the FRONT AXLE.
- Cement the FRONT TIRE ASSEMBLIES to the AXLE PINS.

\*STEERING SHAFT Location. See page eleven.

**SIX**

-Cement both REAR SPRINGS (206 and 207) to the FRAME, with the STABILIZER BAR (203) carefully cemented between the SPRINGS, as shown.

**Fig. 3**

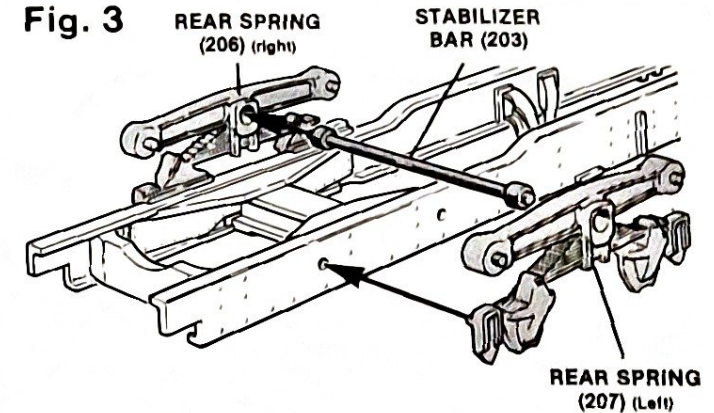

**Fig. 4**

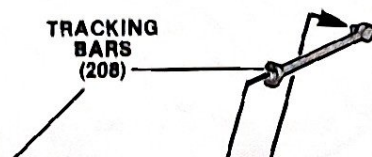

- Cement both halves of the FRONT (217 and 218) and both halves of the REAR (219 and 220) TANDEM AXLE/DIFFERENTIAL together.
- Cement both TANDEM AXLE/DIFFERENTIAL to the REAR SPRINGS trapping the REAR DRIVE SHAFT (221) between the AXLES. The assembled REAR WHEELS onto the AXLES.
- Cement both TRACKING BARS (208) into place between the AXLES and to the front wheel.



- Cement both halves of the two FUEL TANKS together (530 to 529) and (531 to 532).
- Cement the FUEL TANK END CAPS (553) to the TANKS as shown.
- Cement the MAIN STEPS (535 and 527), the FUEL TANK CAP (534) and the TOP STEPS (539 and 538) to the TANKS.
- Cement the FUEL TANK MOUNTING BRACKETS (90) to the FRAME. (Two per side.)
- Cement both halves of the LUBERFINER (536 and 537) and both halves of the BATTERY BOX (81 and 82) and cement the BATTERY BOX to the FRAME.
- Cement the LUBERFINER to the bottom of the BATTERY BOX.
- Cement the ENGINE to the FRAME trapping the FRONT DRIVE SHAFT (212) between the ENGINE and the HOUSING.

Fig. 5

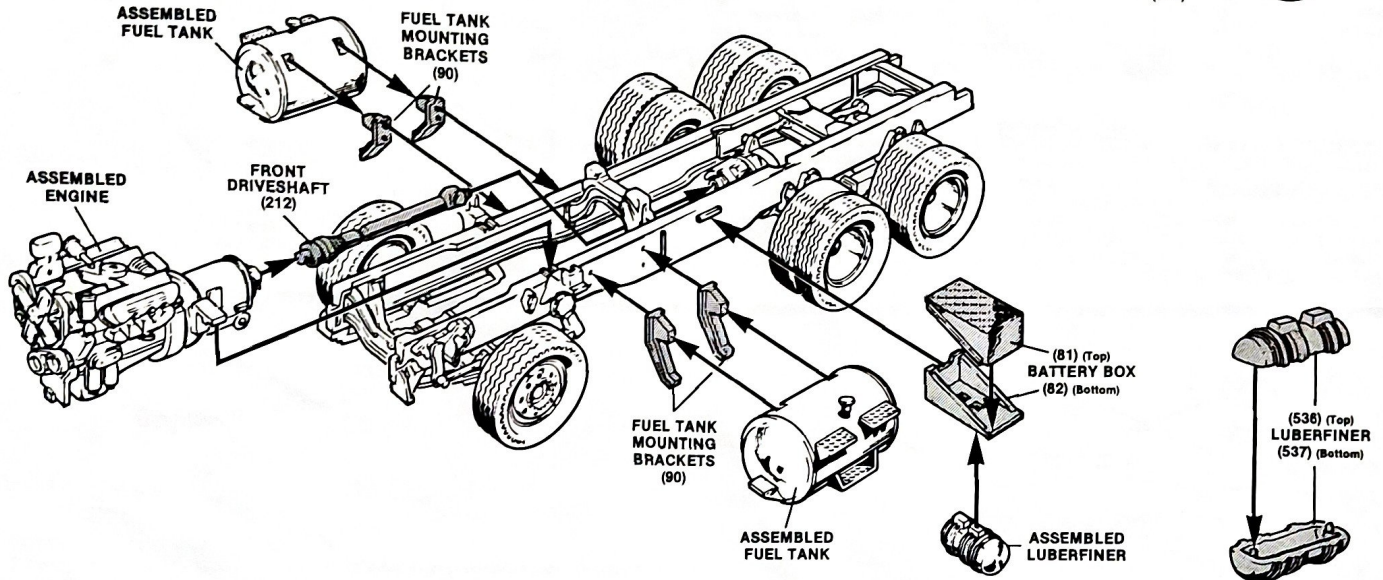
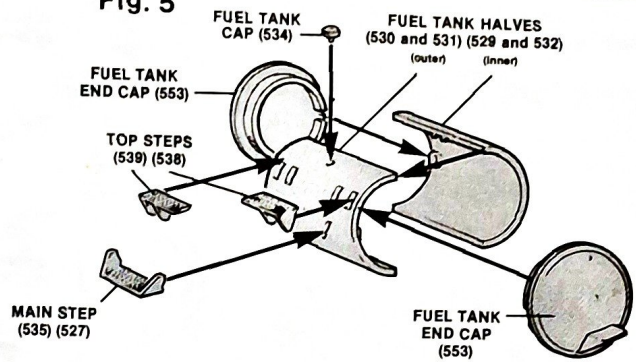

EIGHT

- Cement the FAN SHROUD (53) and the RADIATOR (50) together.
- Cement the RADIATOR to the FRAME.
- Cement both EXHAUST PIPE/MUFFLERS (71 and 72) to the EXHAUST MANIFOLDS. (See ENGINE ASSEMBLY, Fig. 2 and Fig. 3 for location.)
- Cement both RADIATOR HOSES (84 and 85) to the FRONT COVER AND THE RADIATOR.
- Cement the two EXHAUST PIPE ENDS (63) to the EXHAUST PIPE/MUFFLERS. (Dump truck version only.)

Fig. 6

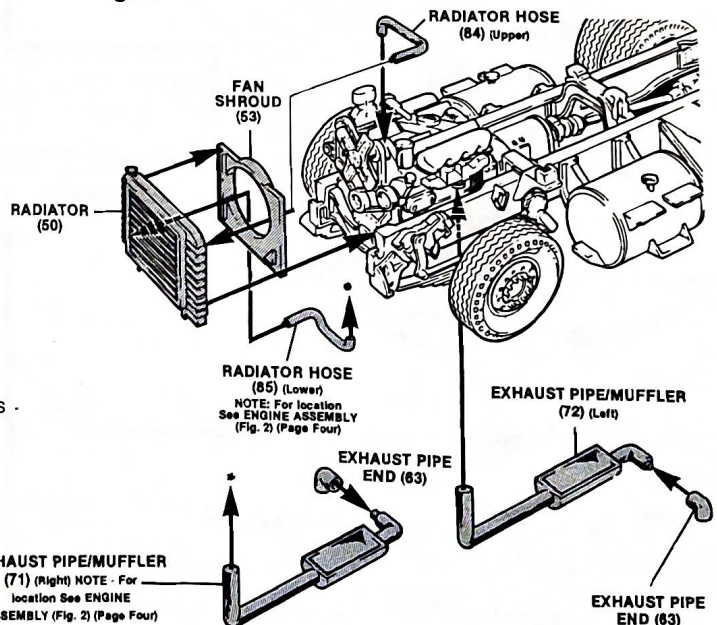

PAINT FAN SHROUD, RADIATOR, RADIATOR HOSES and EXHAUST PIPE/MUFFLERS - BLACK.

CAB/INTERIOR ASSEMBLY

- Carefully open the holes in the roof of the CAB to accommodate the HORNS and RUNNING LIGHTS.
- The CAB and HOOD should both be painted prior to any further assembly. Greater realism can often be obtained by using automotive touch-up paints to match a specific vehicle, but only if properly primed. Always test primers and paints on scrap material to be sure that they do not "eat" into the plastic.

Fig. 1

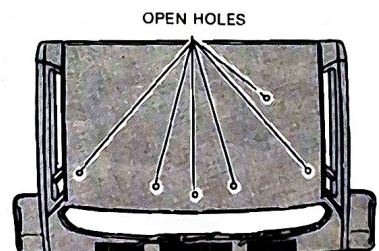

STRAIGHT TRUCK - COLOR OPTIONAL  
DUMP TRUCK - ALL EXTERIOR BODY parts - ORANGE



- Cement the TRANS-QUADRANT HOUSING (52) to the FIREWALL (60).
- Cement both halves of the DRIVERS SEAT BASE (32 and 33) together.
- Cement DRIVERS SEAT, the PASSENGER SEAT (31) and the FIREWALL to the INTERIOR (91).
- Cement THE GAUGE PANEL (61) and the STEERING COLUMN (93) to the INSTRUMENT PANEL (94).
- Cement the STEERING WHEEL (96) and the STEERING SHAFT (509) to the STEERING COLUMN.
- Cement the SHIFT LEVER (533) to the TRANS-QUADRANT HOUSING.
- Cement the INSTRUMENT PANEL to the INTERIOR.
- Cement the DUMP BOX CONTROL LEVER (423) and the BLADE CONTROL UNIT (428) to the DUMP BOX CONTROL UNIT (429) as shown and cement the CONTROL UNIT to the FLOOR of the INTERIOR between the SEATS (SNOW PLOW VERSION ONLY).

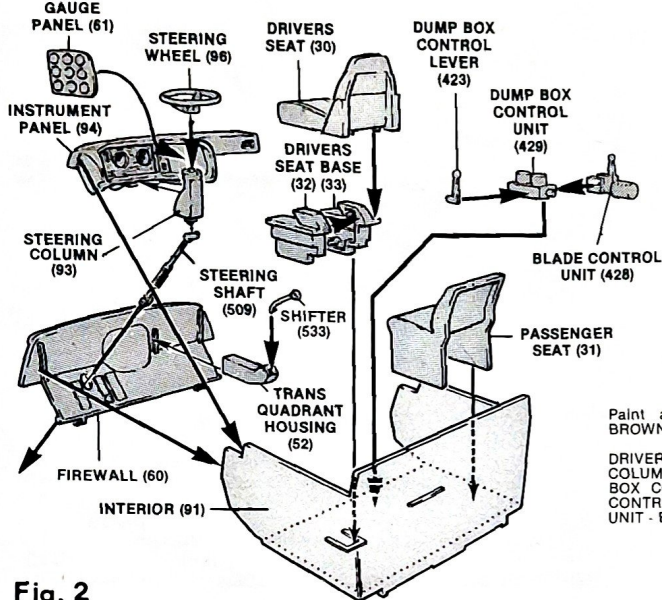

Fig. 2

Paint all INTERIOR Parts LIGHT BROWN unless otherwise indicated.  
 DRIVERS SEAT BASE, STEERING COLUMN, STEERING WHEEL, DUMP BOX CONTROL UNIT, DUMP BOX CONTROL LEVER, BLADE CONTROL UNIT - BLACK.

- Cement the four clear WINDOW PANELS into their respective locations on the inside of the CAB (1).
- Cement the CITIZENS BAND RADIO (51) to the center of the roof of the CAB as shown.
- Cement both AIR TANKS (64) to the bottom of the INTERIOR.
- Cement to INTERIOR into the CAB.

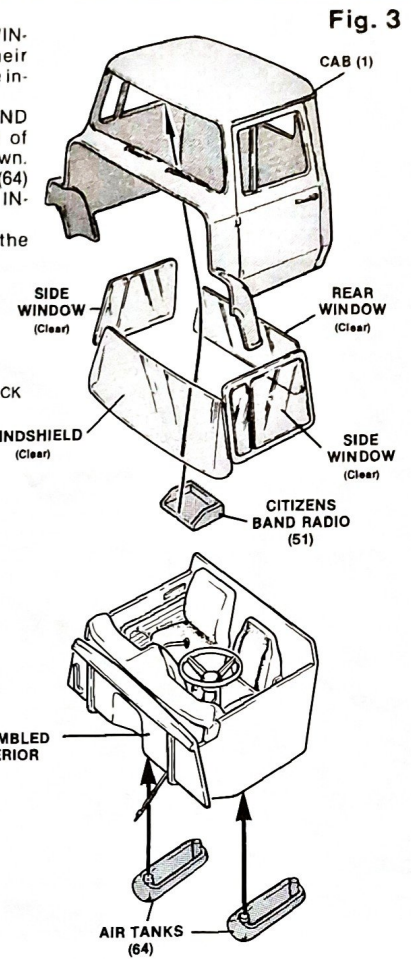

Fig. 3

TEN

FRONT END ASSEMBLY

- Cement both TURN SIGNALS (519), both HEADLIGHT BEZELS (505), the AIR CLEANER COVER (83), and the GRILLE (504) to the HOOD (2).
- Cement the HEADLIGHT LENSES (clear) to the HEADLIGHT BEZELS.

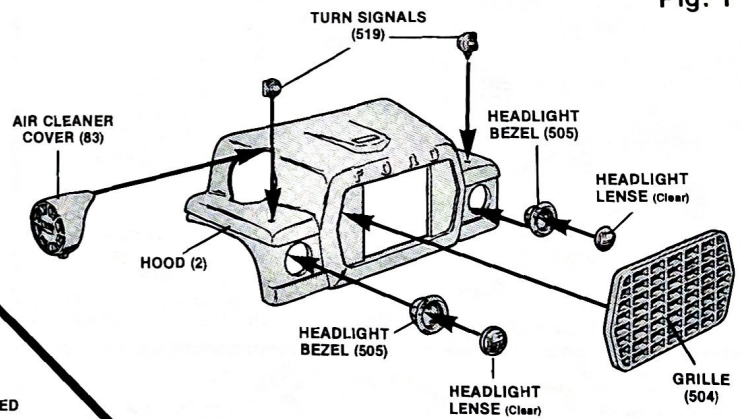
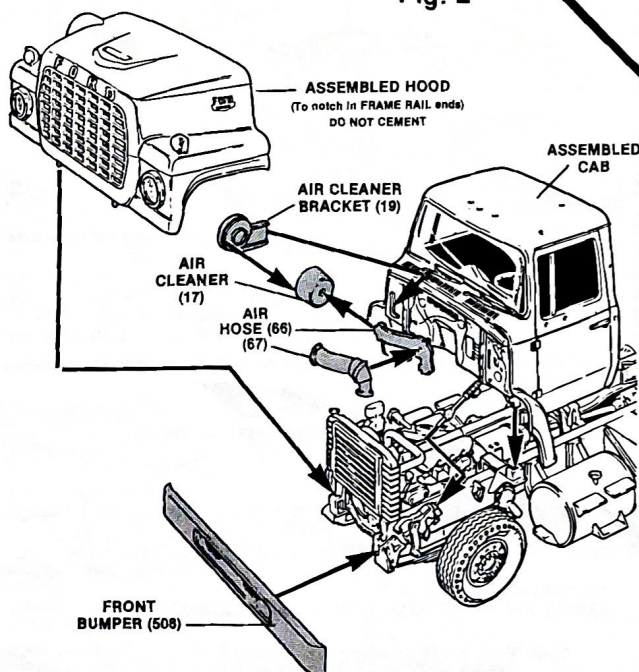

Fig. 1

Fig. 2



- Cement both halves of the AIR HOSE (66 and 67) together.
- Cement the AIR HOSE to the AIR CLEANER (17).
- Cement the AIR CLEANER BRACKET (19) to the FIREWALL.
- Cement the AIR HOSE to the AIR INTAKE MANIFOLD and the AIR CLEANER to the AIR CLEANER BRACKET.
- Cement the FRONT BUMPER (508) to the FRAME.
- Cement the ASSEMBLED CAB to the CAB MOUNTS as shown. (Carefully align the STEERING SHAFT to the STEERING BOX)
- Place the HOOD onto the FRAME.

AIR CLEANER, AIR CLEANER, and AIR HOSES - BLACK

ELEVEN



## FINAL ASSEMBLY (STRAIGHT TRUCK)

- Cement the HAND RAILS (528) to the CAB (both sides).
- Cement the EXHAUST STACKS (510 and 511) to the CAB. (510 shown) (511 other side).
- Cement the AIR CONDITIONER GRILLE (540) to the AIR CONDITIONER (55) and cement the AIR CONDITIONER to the center of the roof of the CAB.
- Cement the 5 RUNNING LIGHT LENSES (amber) to the RUNNING LIGHT BEZELS (503).
- Cement the RUNNING LIGHTS and the AIR HORNS (520) to the roof of the CAB.

AIR CONDITIONER - BODY COLOR

- Cement both FRAME RAIL EXTENSIONS (222), the SLIDE PLATE (201), and the DECK PLATE (551) to the FRAME as shown.
- Cement the two MUD FLAPS (214 and 210) to the FRAME RAIL EXTENSIONS.
- PRESS THE 5th WHEEL (550) onto the 5th WHEEL CARRIER (202) and cement the CARRIER to the SLIDE PLATE.

-Paint all parts - BLACK.

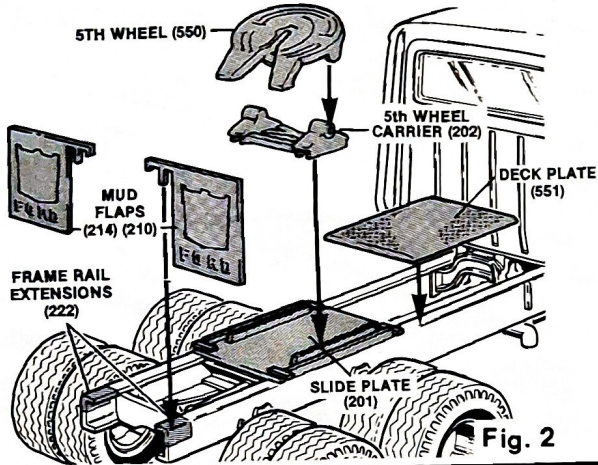
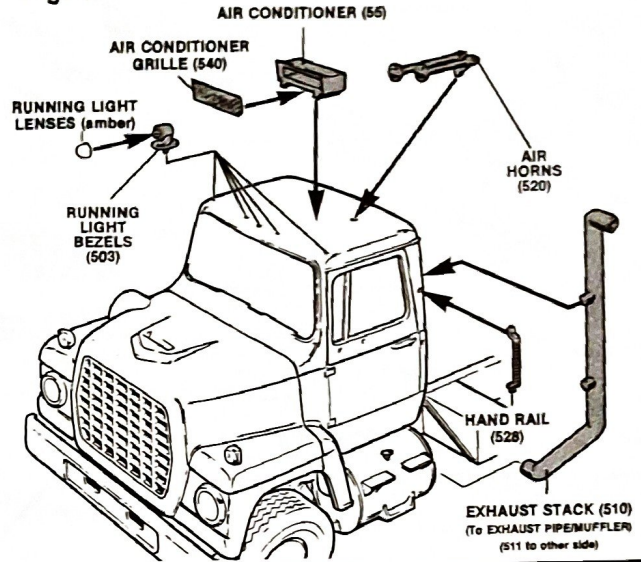

Fig. 2

Fig. 1



- Cement the TAILLIGHT BEZEL/LICENSE PLATE BRACKET (213) to the right FRAME RAIL.
- Cement the other TAILLIGHT BEZEL (216) to the left FRAME RAIL.
- Cement the TAILLIGHT LENSES (red) to the BEZELS.
- See page eighteen for TAILLIGHT selection.

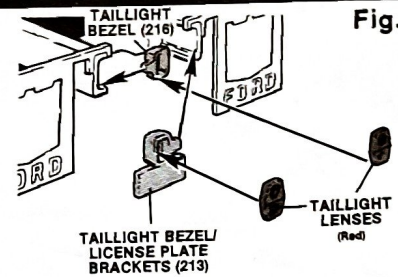

Fig. 3

TWELVE

## DUMP TRUCK: BOX/HOIST ASSEMBLY

- Cement both UNDERBODY FRAME RAILS (321 and 322) to the DUMP BOX FLOOR (300).
- Cement the MUD FLAP RETAINER (306) to the MUD FLAPS (210 and 214). (Note: Remove "Tabs".)
- Slide the remaining METAL AXLE through the holes of the FRAME RAILS as shown.
- Slip the MUD FLAPS onto the METAL AXLE.
- Cement the HINGE RETAINER (316) to the HINGE SUPPORT (313) trapping the METAL AXLE between them as shown.

-Paint all DUMP BOX/HOIST PARTS ORANGE unless otherwise indicated MUD FLAPS - BLACK

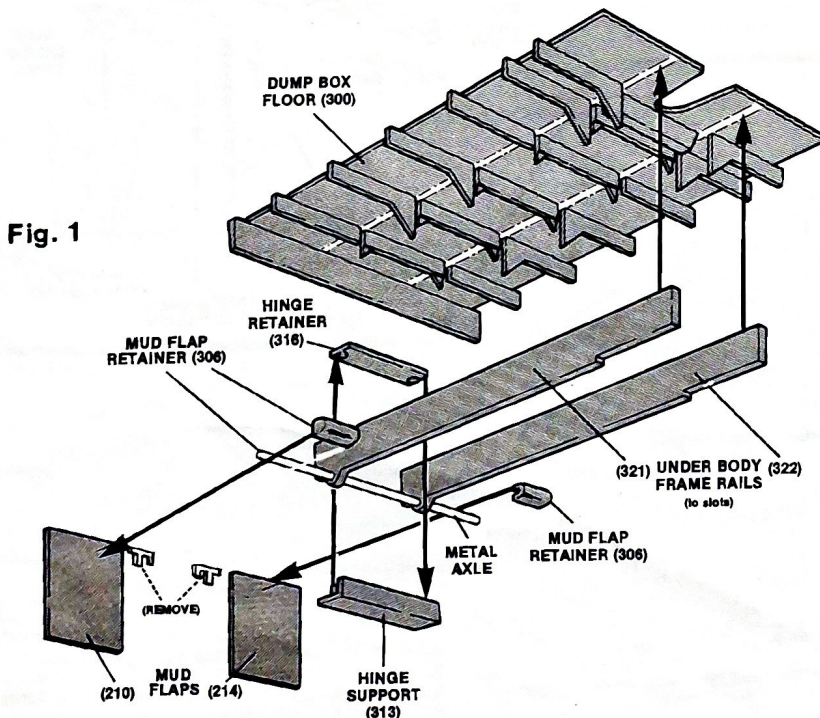
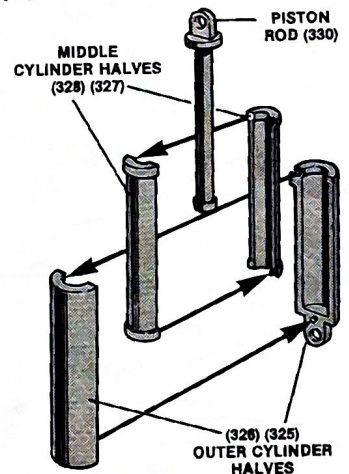

Fig. 1

- Cement both halves of the MIDDLE CYLINDER (328 and 327) together around the trapping the PISTON ROD (330) inside.
- Cement both halves of the OUTER CYLINDER (326 and 325) together around the MIDDLE CYLINDER.
- (Apply cement carefully so that the PISTON ASSEMBLY can "TELESCOPE" freely.)

Fig. 2



PISTON ROD, MIDDLE CYLINDER - SILVER

THIRTEEN



-Cement the SIDE PANELS (323 and 319) to the SIDE REINFORCEMENT FRAMES (324 and 320).  
 -Cement the SIDE REINFORCEMENT FRAMES and the DUMP BOX FRONT PANEL (333) to the DUMP BOX FLOOR ASSEMBLY.

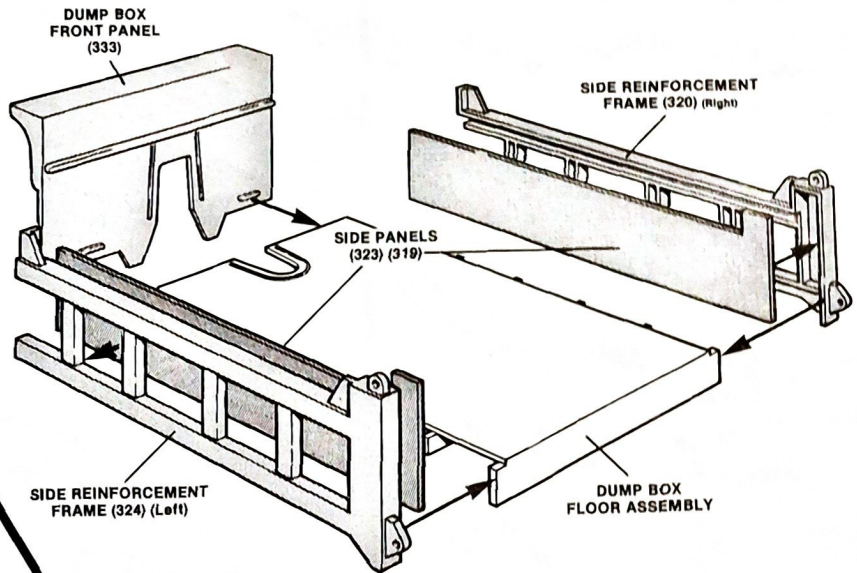
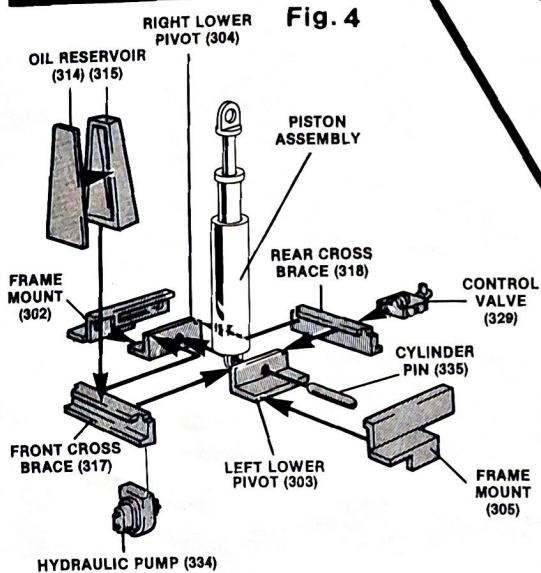

Fig. 4



-Cement both halves of the OIL RESERVOIR (314 and 315) together.  
 -Cement both the RIGHT (304) and LEFT (303) LOWER PIVOTS to the FRONT (317) and REAR (318) CROSS BRACE as shown.  
 -Slide the CYLINDER PIN (335) through one of the LOWER PIVOTS, and PISTON ASSEMBLY, to the other LOWER PIVOT and cement into place. (DO NOT get cement on the PISTON ASSEMBLY.)  
 -Cement both FRAME MOUNTS (302 and 305) into position as shown.  
 -Cement the OIL RESERVOIR and the HYDRAULIC PUMP (334) to the FRONT CROSS BRACE.  
 -Cement the CONTROL VALVE (329) to the REAR CROSS BRACE.

FOURTEEN

-Cement the DUMP BOX GUIDES (328 and 332) and the HOIST ASSEMBLY to the FRAME as shown.  
 -Position the PISTON ASSEMBLY through the "NOTCHED" area at the FRONT of the DUMP BOX FLOOR and cement the HINGE SUPPORT to the FRAME as shown.  
 -Cement both halves of the HOIST HOUSING (312 and 311) together, trapping the PISTON ROD between them and cement the HOUSING to the FLOOR and FRONT PANEL. (Work Carefully, DO NOT get cement on the PISTON ROD.)

Fig. 5

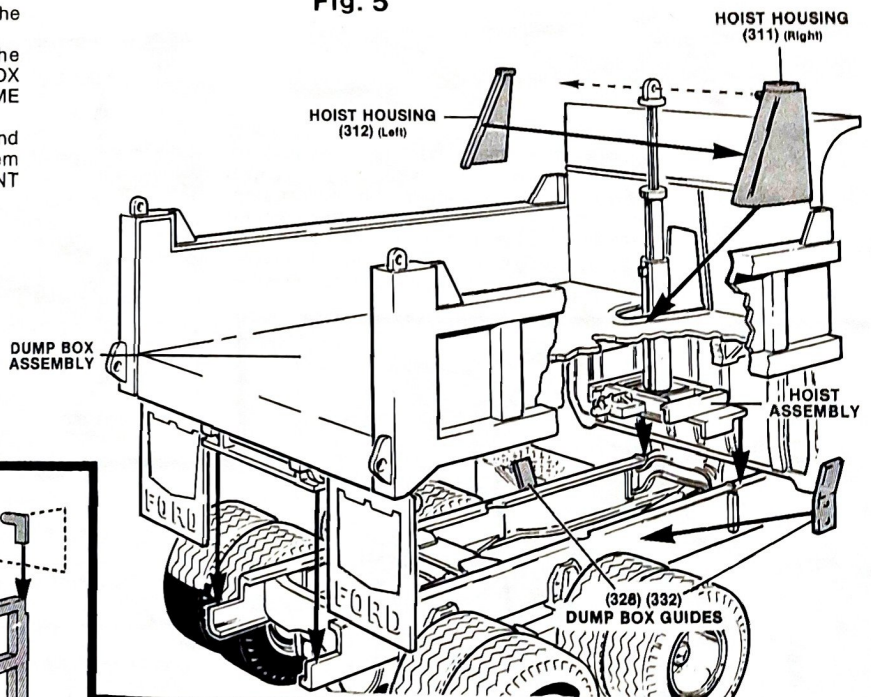
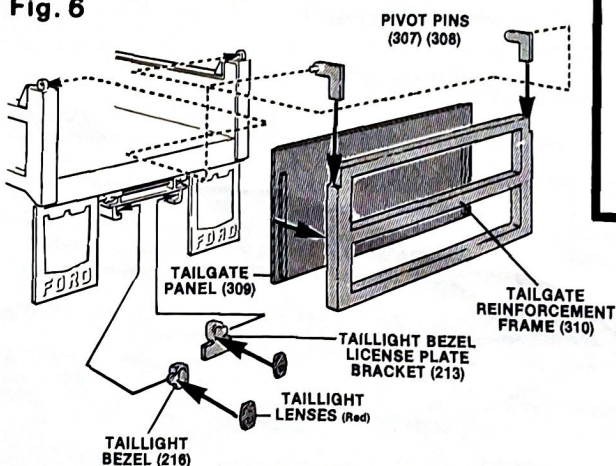

Fig. 6



-Cement the TAILGATE PANEL (309) and the two PIVOT PINS (307 and 308) to the TAILGATE REINFORCEMENT FRAME (310).  
 -Carefully SNAP the TAILGATE into place between the REINFORCEMENT FRAMES. (DO NOT CEMENT.)  
 -Cement the TAILLIGHT BEZEL/LICENSE PLATE BRACKET (216) to the right FRAME RAIL.  
 -Cement the other TAILLIGHT BEZEL (213) to the left FRAME RAIL.  
 -Cement the TAILLIGHT LENSES (red) to the BEZELS as shown.  
 -See page eighteen for LENSE selection.



# SNOW PLOW ASSEMBLY

- Carefully position the BLADE MOUNT (403) on to the PUSH BOX (406).
  - Cement the BLADE MOUNT RETAINER (427) and the FRAME MOUNT (402) to the PUSH BOX. ("HEAT SWAGE" the pin on the front of the PUSH BOX to hold the BLADE MOUNT.
  - Cement the HITCH BRACES (412 and 413) and the HITCH (408) to the HITCH TELESCOPE (414).
  - Cement the HITCH CYLINDER (407) to the HITCH and the HITCH TELESCOPE.
  - Cement the HITCH TELESCOPE to the FRAME MOUNT.
  - Cement both halves of the TRIP CYLINDER (400 and 401) together.
  - Cement the TRIP CYLINDER MOUNTS (404 and 405) to the BLADE MOUNT trapping the TRIP CYLINDER in between.
  - Cut two pieces of VINYL TUBING four inches long and cement the sections between the BLADE MOUNT and the HITCH.
- We recommend using an instant bond type of cement when attaching the tubing.

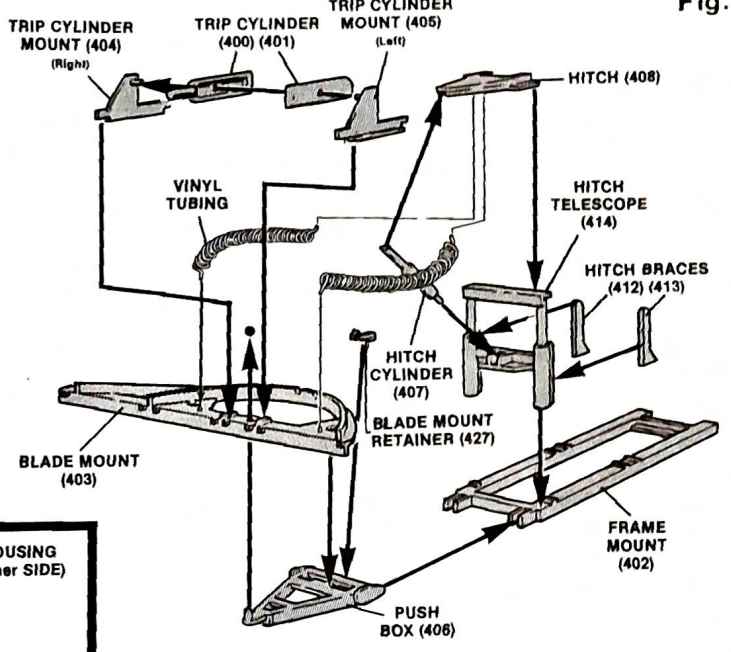

-Paint all SNOW PLOW PARTS (EXCEPT HOSES) ORANGE

● HEAT SWAGE: See Page Eighteen

Fig. 2

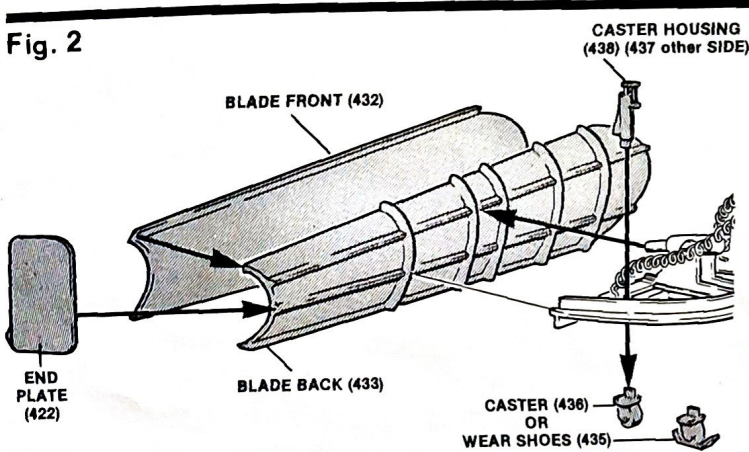

- Cement both halves of the BLADE (432 and 433) together.
- Cement the END PLATE (422) to the BLADE.
- Place the CASTER HOUSING (438 and 437) through the holes of the BLADE MOUNT.
- Carefully cement the CASTORS (436) or the WEAR SHOES (435) to the CASTER HOUSINGS.
- Cement the BLADE TO THE BLADE MOUNT.
- Cement the TRIP CYLINDER to the BLADE.

## SIXTEEN

### FINAL ASSEMBLY (DUMP TRUCK/SNOW PLOW)

- Cement both HAND RAILS (528) to the side of the CAB (one each side).
- Cement the RUNNING LIGHT LENSES (Amber) to the RUNNING LIGHT BEZELS (503). (Ref: Page eighteen for LENSE selection.) Cement the RUNNING LIGHTS to the roof of the CAB.
- Cement the AIR HORNS (520) to the roof of the cab.
- Cement the AIR CONDITIONER GRILLE (504) to the AIR CONDITIONER HOUSING (55). Cement the AIR CONDITIONER to the roof of the CAB (optional).

### SNOW PLOW

- Cement the BUMPER MOUNT (441) to the center of the FRONT BUMPER as shown.
- Slide the FRAME MOUNT of the "PLOW" under the FRAME (above the FRONT AXLE). Cement the HITCH BRACES to the BUMPER MOUNT.
- Cement the "FLASHER" (Amber) to the FLASHER BASE (431). Cement the FLASHER UNIT to the roof of the CAB. See page eighteen for "FLASHER" selection.

AIR CONDITIONER - ORANGE

### REAR VIEW MIRROR ASSEMBLY

- Cement the REAR VIEW MIRROR (524) and the MIRROR BRACKET (516) together as shown.
- Cement the UPPER (521) and LOWER (522) BRACES to the BRACKET.
- Cement the BRACKETS to the CAB as shown.
- Note: SUBSTITUTE 523 for 522 and 515 for 516 on the passenger side.

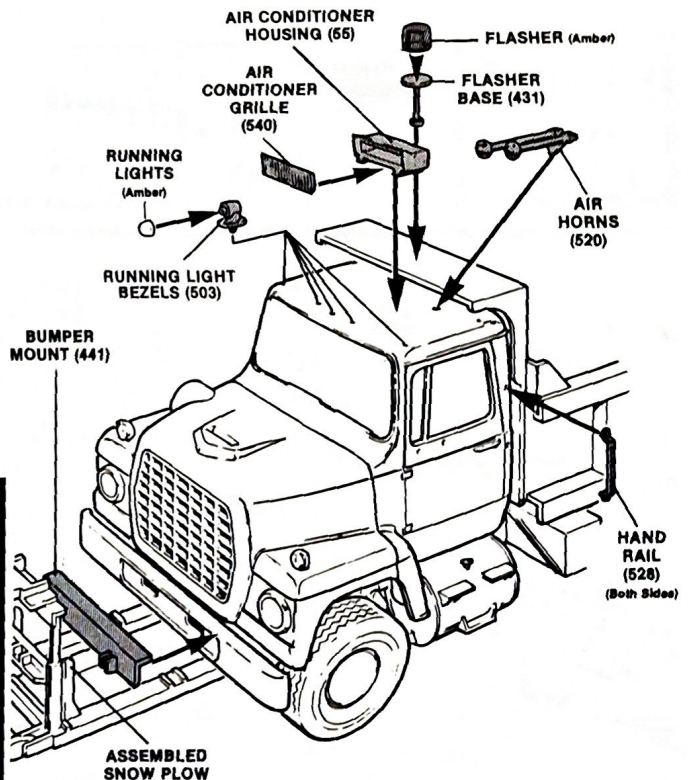
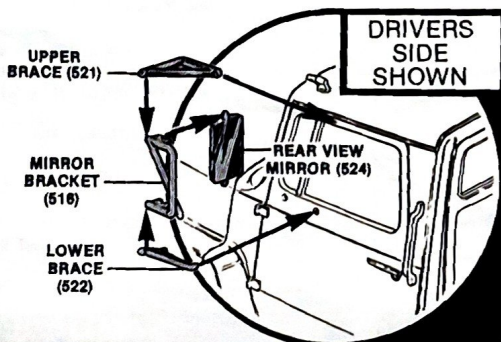



## SALT SPREADER ASSEMBLY (SNOW PLOW: OPTIONAL)

- Cement the SPINNER (434) and the SPINNER BAND (410) to the SPINNER MOUNT (409).
- Cement both SPREADER ENDS (418 and 417) and the SPINNER MOUNT to the SPREADER PAN (421).
- Cement the AUGER MOTOR (426) to the RIGHT SPREADER END as shown.
- Cement the AUGER (419) between the SPREADER ENDS.
- Cement the AUGER PLATE (430) to the SPREADER PAN above the AUGER.
- Cement the SPREADER to the back of the DUMP BOX.
- Cement the TAILGATE FILLER PANELS to the inside of the TAILGATE.  
(Test fit the FILLER PANELS inside the DUMP BOX before cementing.)
- Snap the TAILGATE into position.
- Place the COVER PLATE (42) onto the SPREADER PAN (cement not necessary). COVER PLATE can be displayed in either the UP (shown) position or DOWN (indicated) position.

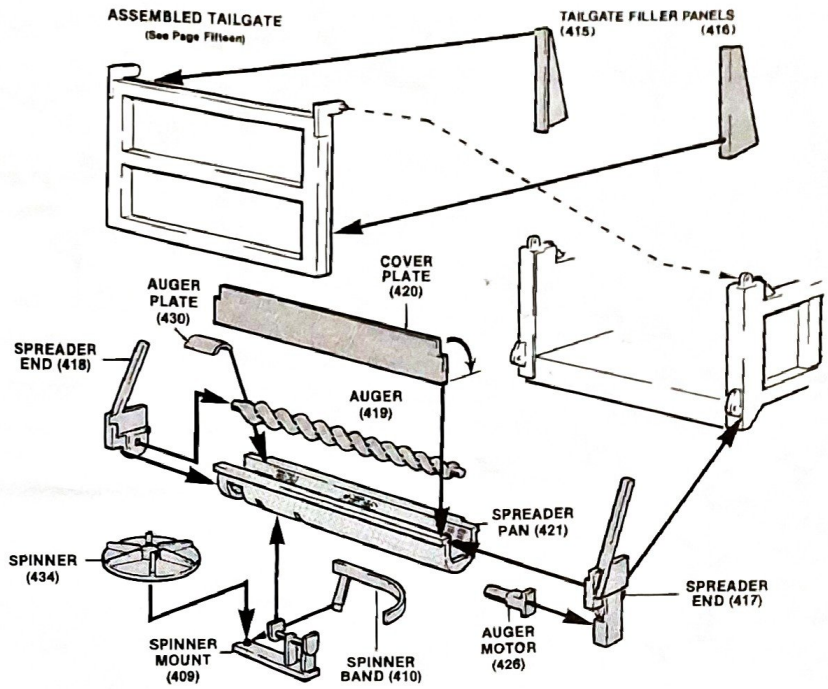

Paint all SALT SPREADER parts - ORANGE

## HEAT SWAGE

When HEAT SWAGE is indicated, this means to heat the tip of the knife in a candle or match flame. When touched to the plastic, the plastic will soften and form a mushroom head.

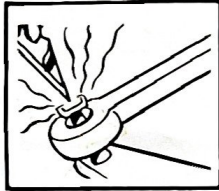

## LENSE SELECTION

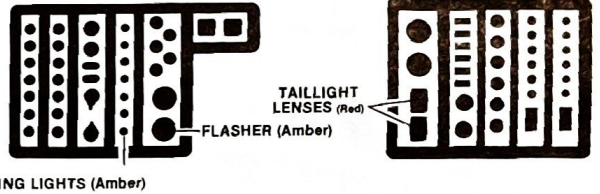

EIGHTEEN

## Decal and Painting Instructions

Apply decals by first trimming them individually from the decal sheet. Soak them in lukewarm water for 10 to 15 seconds. Gently slide the decal from the backing paper onto the surface of the model. Blot excess water with a tissue, gently pressing decal onto model surface. Allow decals to dry for an hour or more before handling model.

Optional decals for semi-tractor:

Optional decals for semi-tractor:

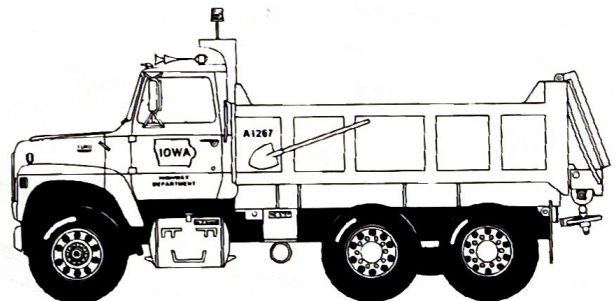
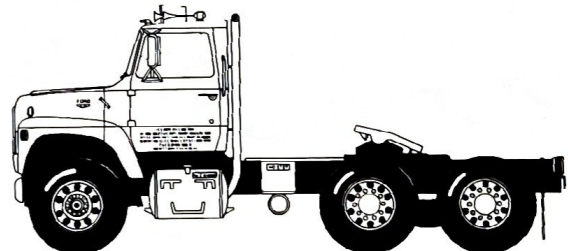



**3 in 1 from Racing Champions Ertl, Inc.**  
**This model can be built**  
**one of three ways:**  
**Snow Plow**  
**Dump Truck**  
**or Semi Tractor**

## **DUMP TRUCK**

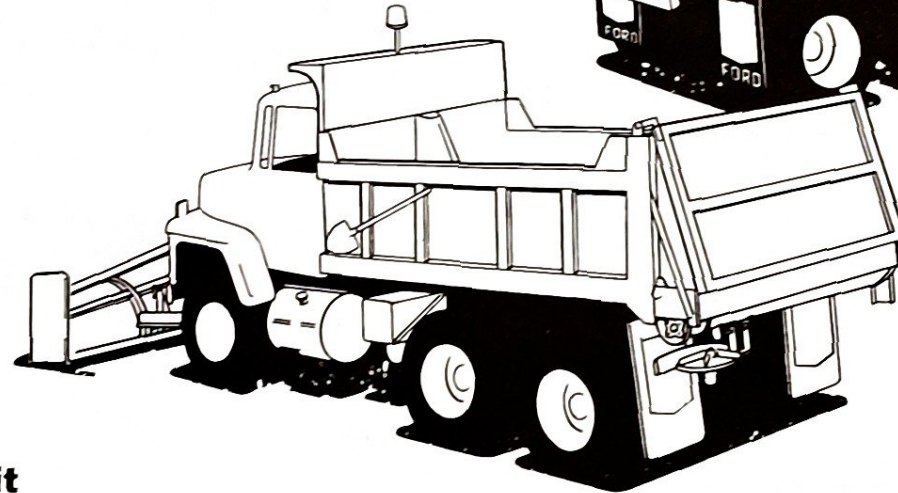
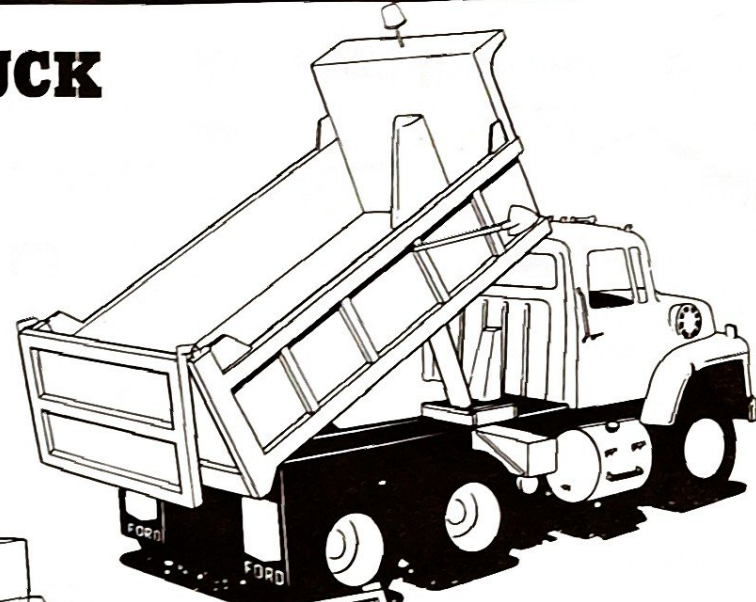

## **SNOW PLOW**

### **Parts Not Used in This Kit**

You will find extra parts that are not used in this kit.  
You may keep them for your "parts box" or they  
may be discarded as you wish.

## **SEMI TRACTOR**

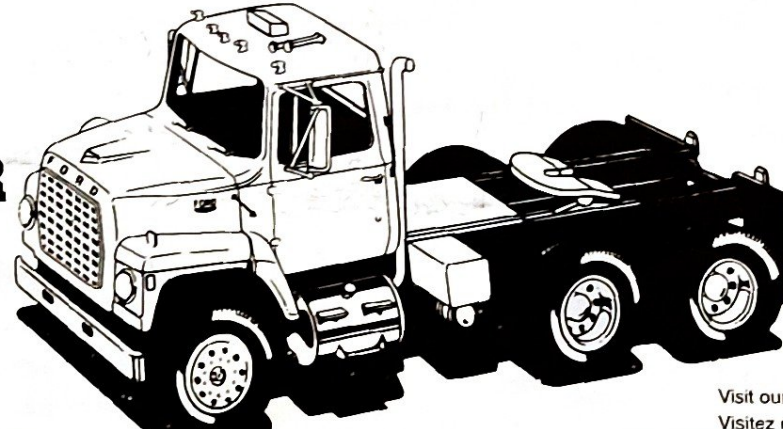

Official Licensed Product

*Ford Motor Company*



©2002 RC ERTL, INC. Dyersville, Iowa 52040-0500 U.S.A.

Visit our website at [www.RCERTL.com](http://www.RCERTL.com)  
Visitez notre site web au [www.RCERTL.com](http://www.RCERTL.com)