

# AH-64E *APACHE GUARDIAN*

## ATTACK HELICOPTER

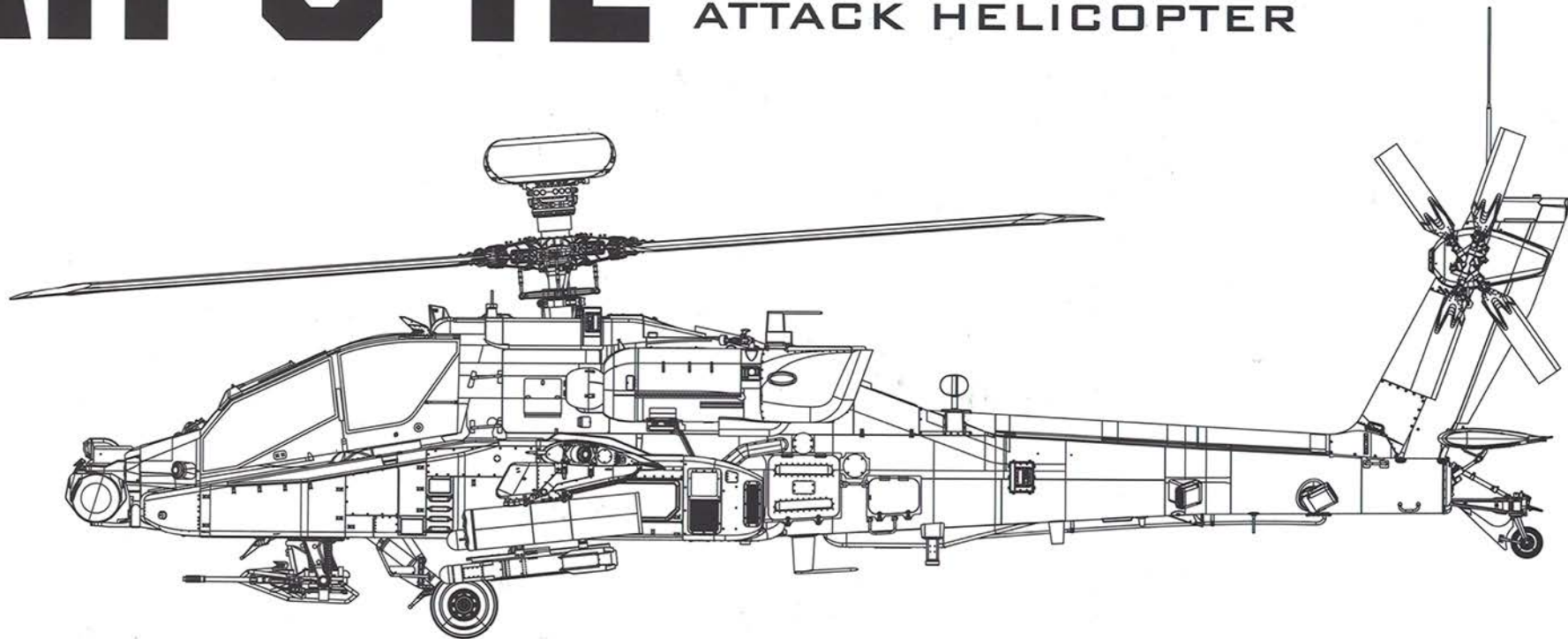

Beginning in the late 1980s, the US Army planned a series of upgrades to its AH-64A fleet. In 1992 McDonnell Douglas converted four AH-64As into prototypes for the variant designated AH-64D. The designations AH-64B and AH-64C for interim variants were later dropped so that the AH-64D became the second operational Apache variant.

The main upgrade focused on the Northrop Grumman AN/APG-78 Longbow millimeter-wave fire-control radar (FCR) target acquisition system and the Radar Frequency Interferometer (RFI) housed in the radome mounted on the mast above the main rotor shaft. This allows the AGM-114L to be fired in an autonomous fire-and-forget mode, whereas the laser-guided Hellfire requires external designation or use in conjunction with the TADS, and as such is a line-of-sight weapon. The AN/APG-78 radar can detect, classify and prioritize 12 targets simultaneously, and can see through the fog and smoke that currently disrupts infra-red and TV sensors. The AH-64D also features improvements in targeting, battle management, cockpit, communications, weapons and navigation systems. The forward avionics bay was expanded, and the landing gear fairings were extended forward to accommodate some of the new equipment. This gunship can carry a total of 16 AGM-114L Hellfire 2 anti-tank missiles and can also carry 2 AGM-122 Sidarm air-to-ground anti-radiation missiles. For self-defense against other aircraft, the Longbow Apache can carry 4 AIM-92 Stinger, 4 Mistral, or 2 AIM-9 Sidewinder short-range air-to-air missiles.

The AH-64E Apache Guardian is the latest version of the Apache, and up until 2012 it was designated as AH-64D Block III. It has several improvements and upgrades, including more powerful General Electric T700-GE-701D engines and upgraded transmission. This helicopter can also be fitted with updated Longbow fire control radar. The US armed forces are upgrading a total of 634 AH-64D helicopters to AH-64E standard, with deliveries beginning in 2011. This helicopter has also been exported to Saudi Arabia, India, Indonesia, and Taiwan, and has been ordered by Iraq and South Korea.

# READ BEFORE ASSEMBLY

## CAUTION

- Read carefully and fully understand the instructions before commencing assembly. A supervising adult should also read the instructions if a child assembles the model.
- When assembling this kit, tools including knives used. Extra care should be taken to avoid personal injury.
- Keep out of reach of small children. Children must not be allowed to suck any part, or pull vinyl bag over their heads.



Be Careful



Optional



Do Not Cement



Drill



Remove



Instant Glue for Metal

## PAINTS REQUIRED

Color info and profiles by Mig Jimenez

A.MIG-0025 RLM 83  
Olive Drob Dark

A.MIG-0278 Nato Black

A.MIG-0033 Rubber & Tires

A.MIG-0043 Gun Metal

## APPLYING DECALS

1. Clean the model surface with a wet cloth.
2. Cut out each decal design from sheet, and dip it in tepid water for 15~20 sec.
3. Hold the backing sheet edge and slide decal onto the model.
4. Move decal into position by wetting decal with finger.
5. Press decal gently down with a soft cloth until excess water and air bubbles are gone.

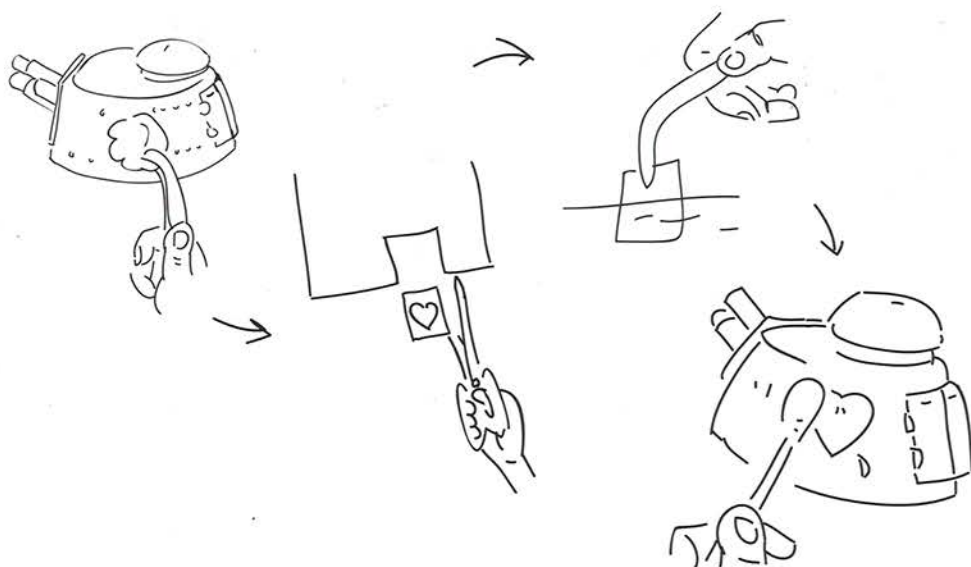

## REMOVING PE

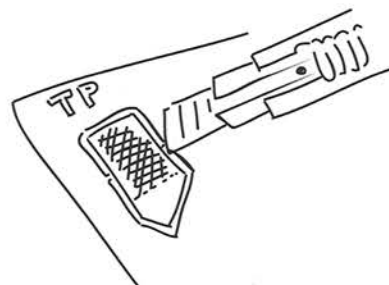

Be careful not to hurt when removing PE parts.

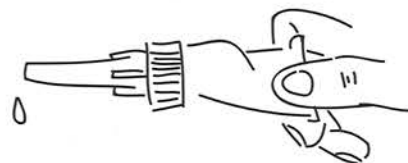

Secure using instant glue (not included).

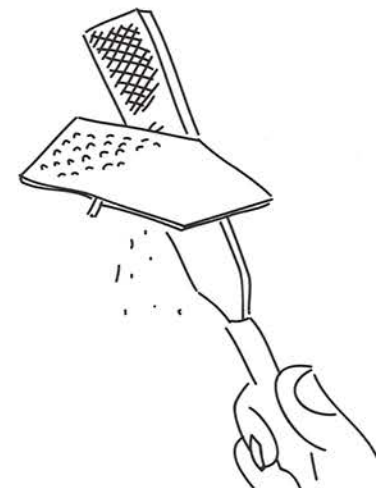

Finish using file.

# PARTS

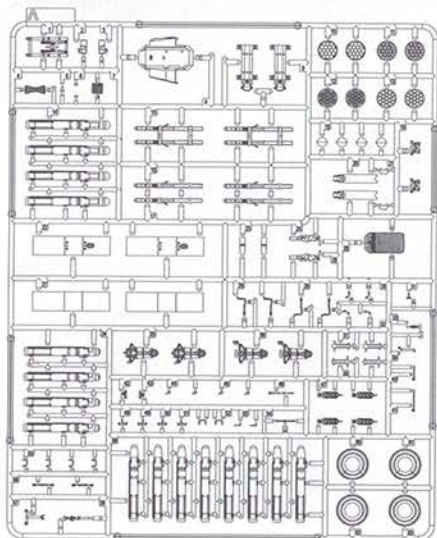

X2

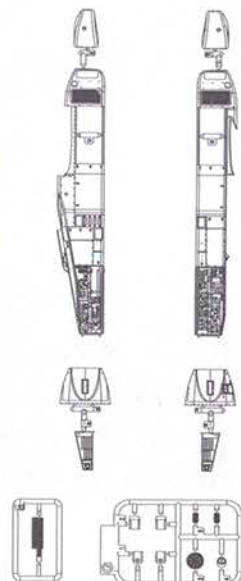
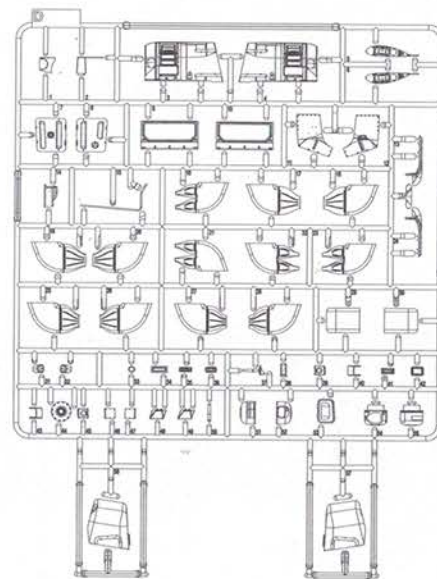
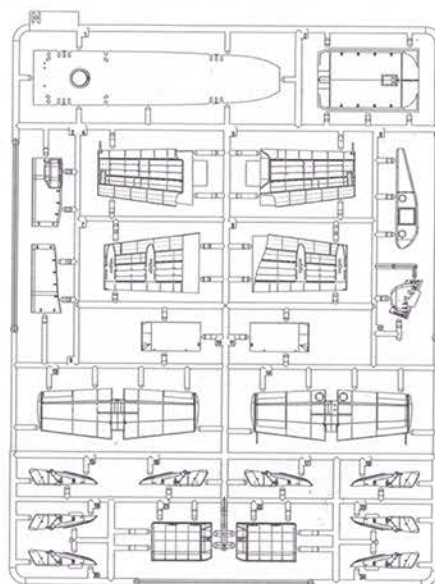
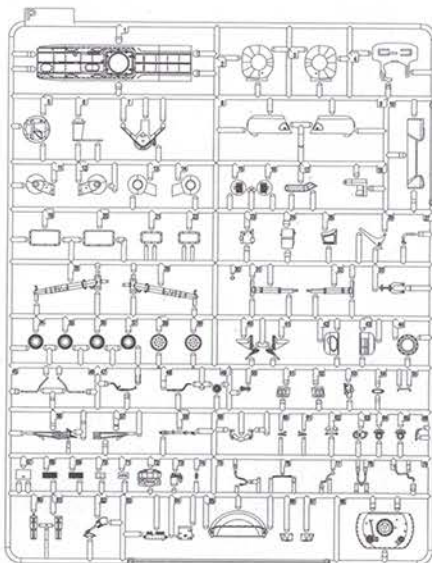

X2

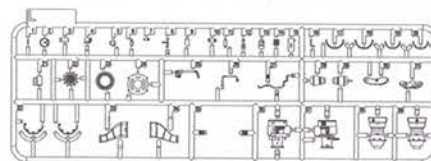
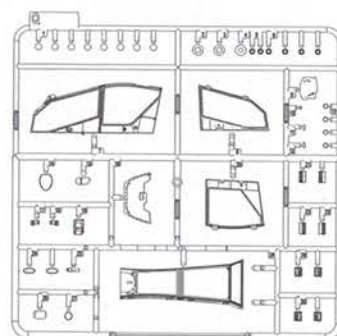
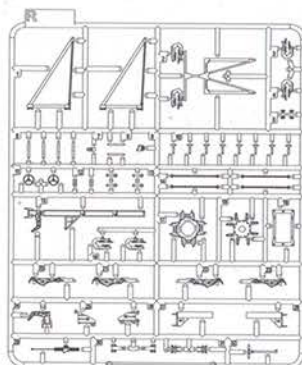
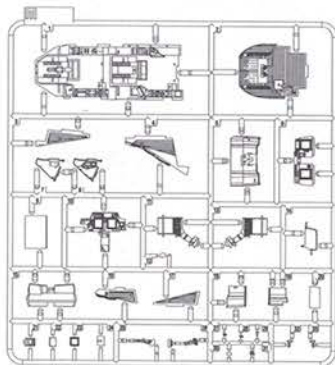
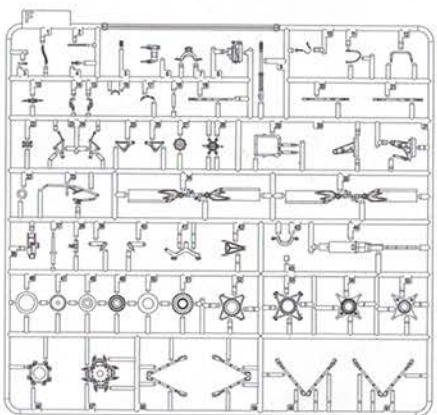

X2

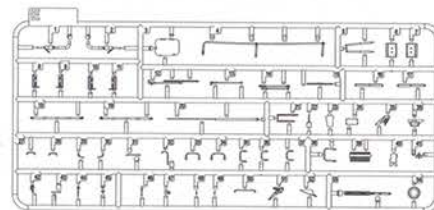

Decal

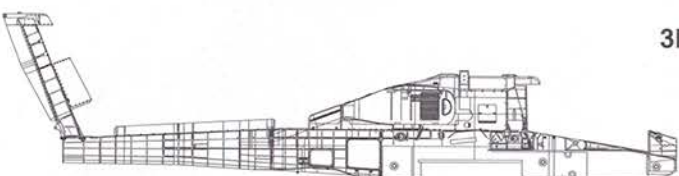

S

3D Part



T

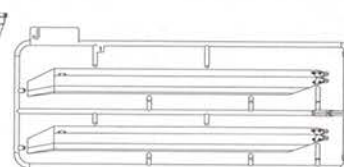

X2

Line

Metal Cylinder  
X8

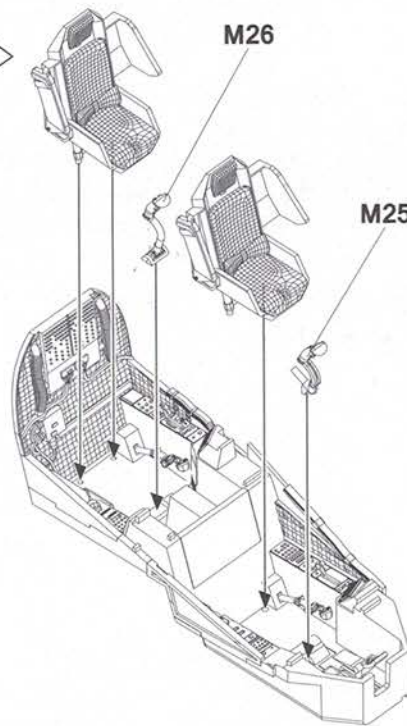
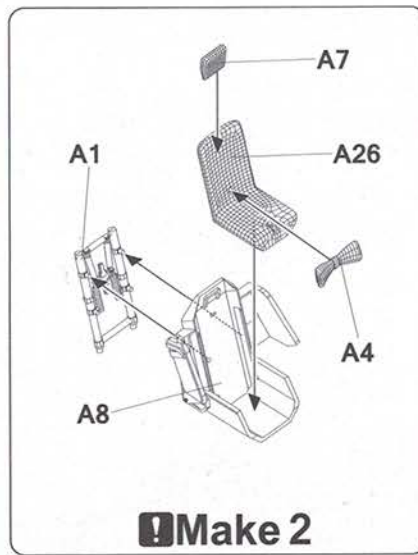
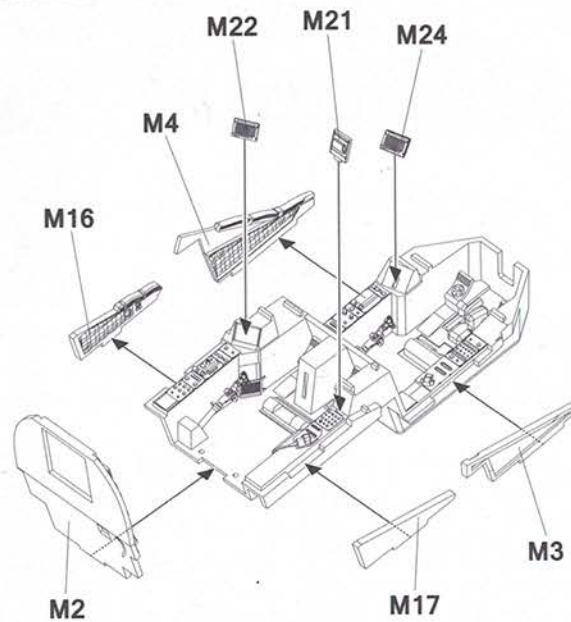
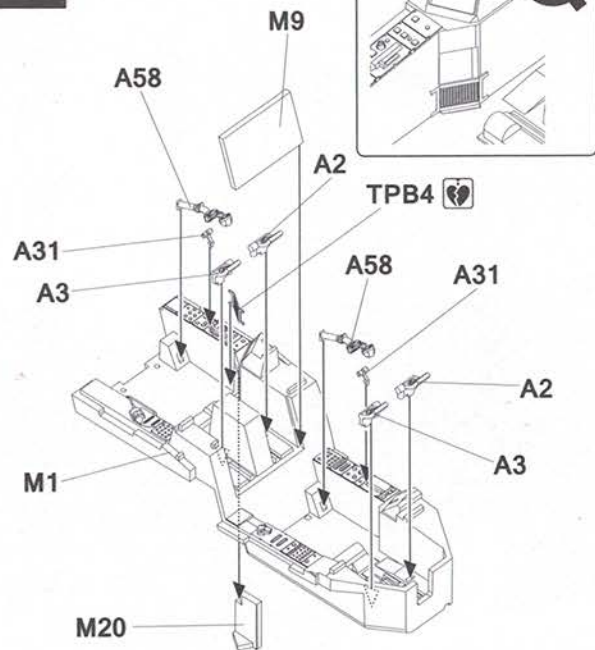
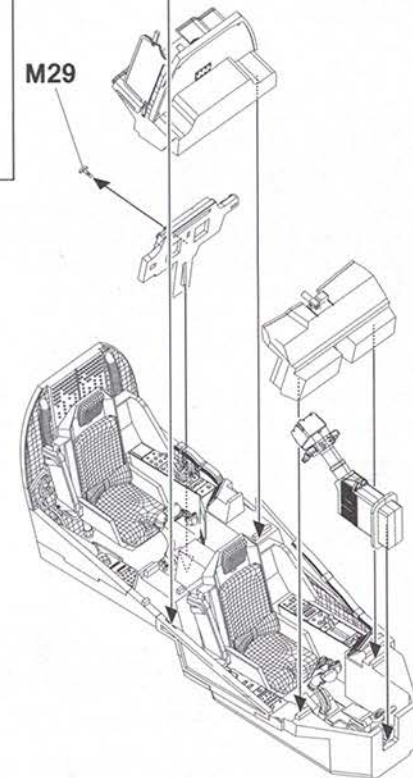
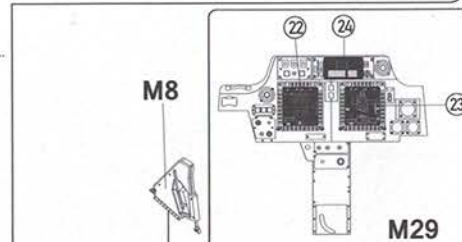
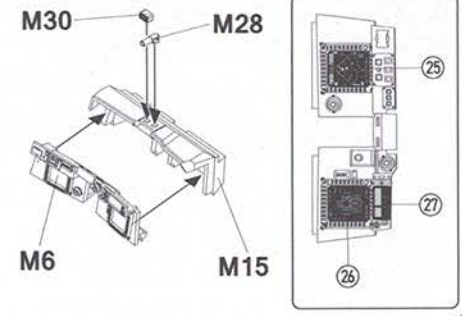
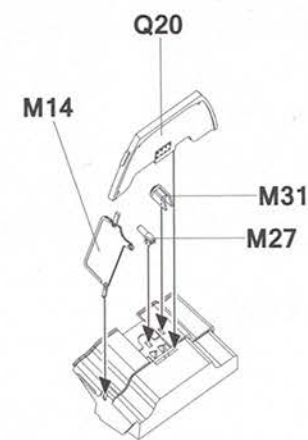
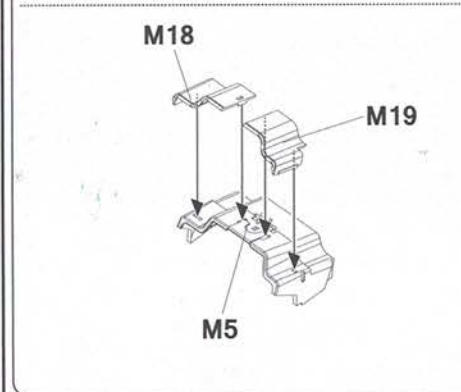
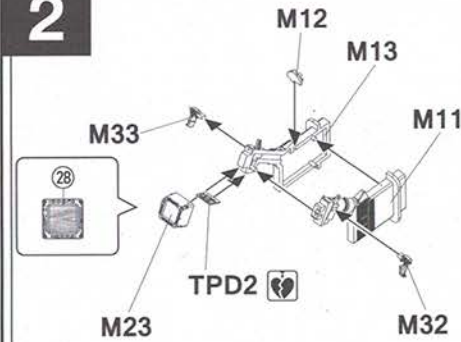

TP

**1****2****3**

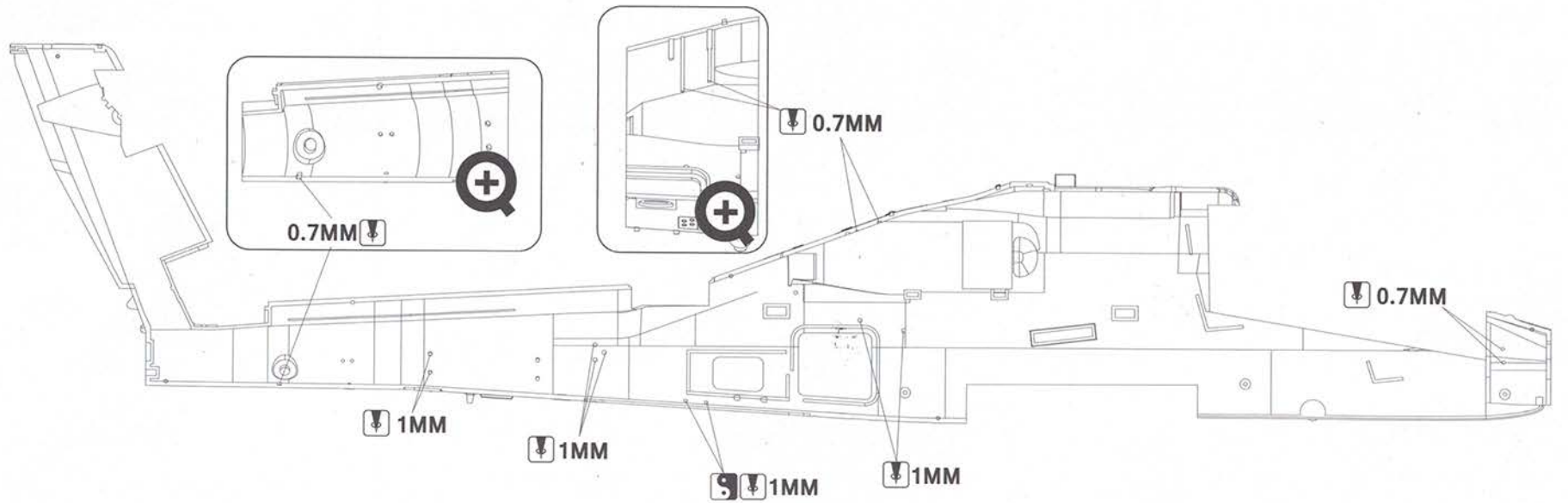
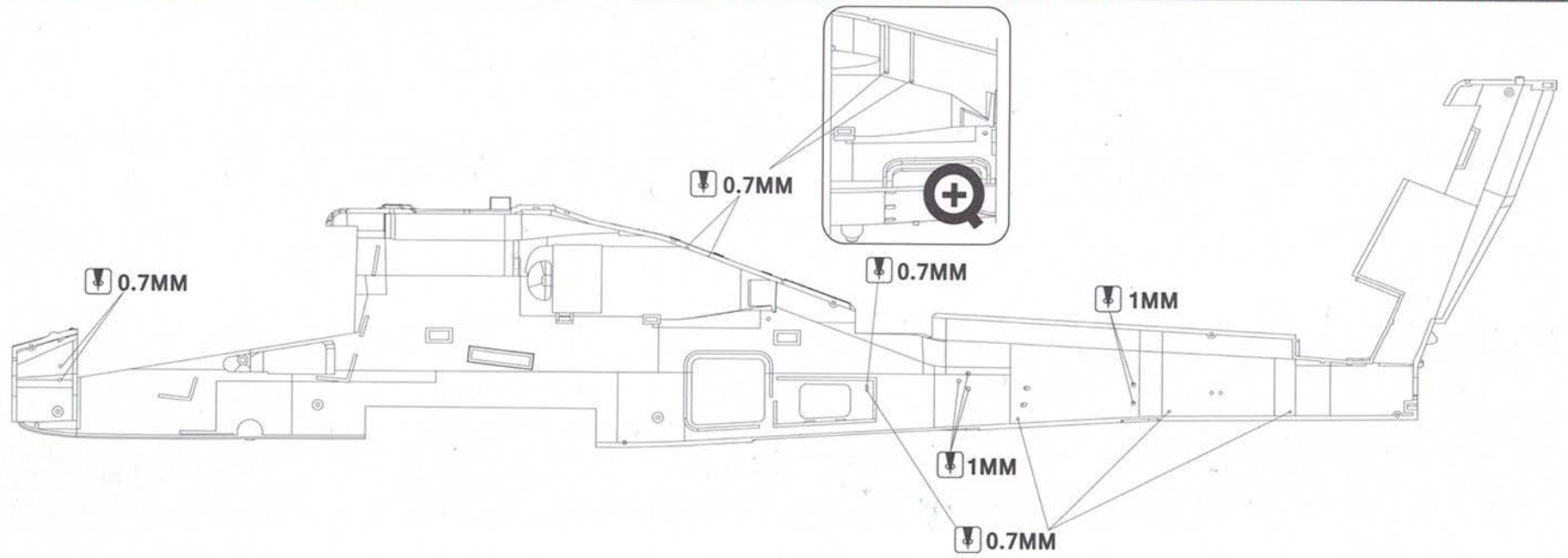

4

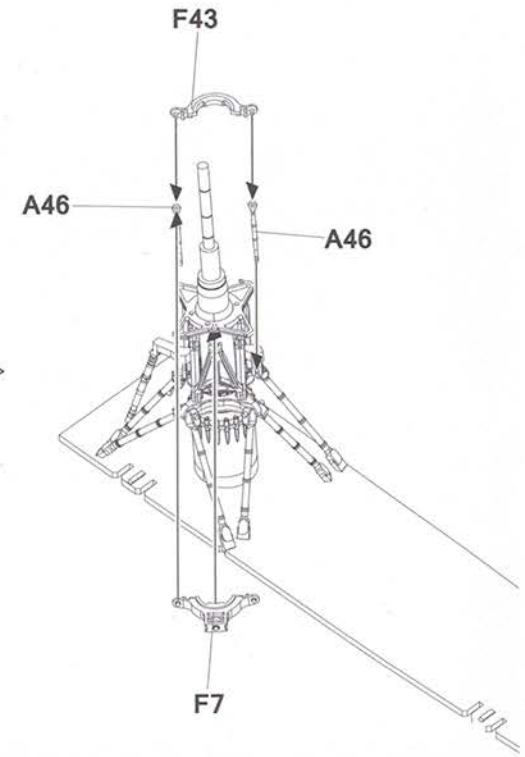
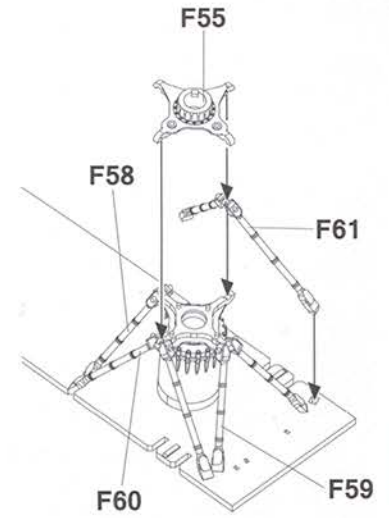
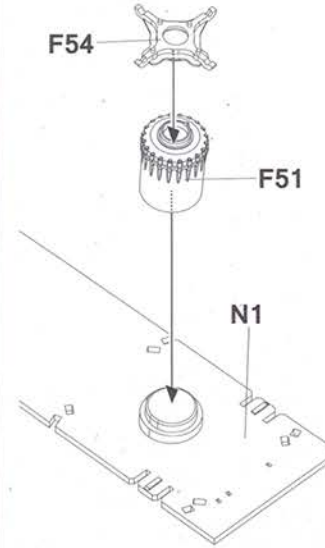
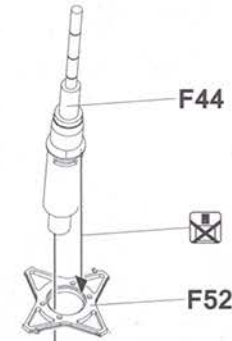
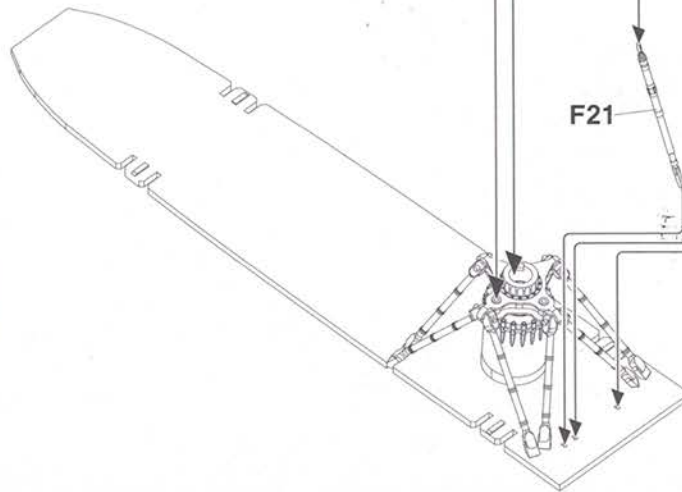
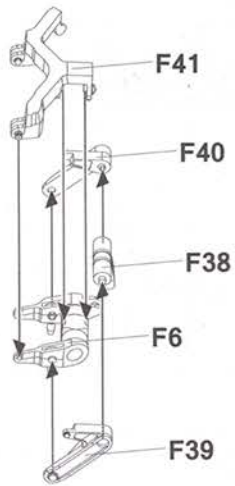
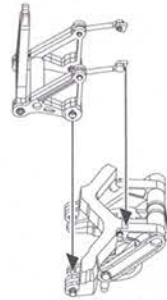
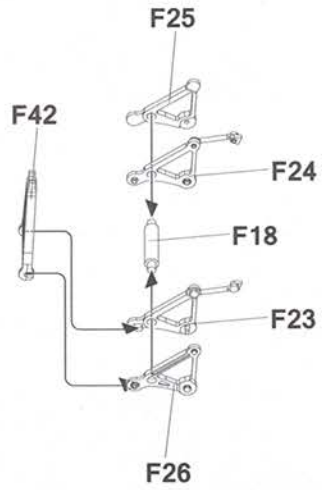

5

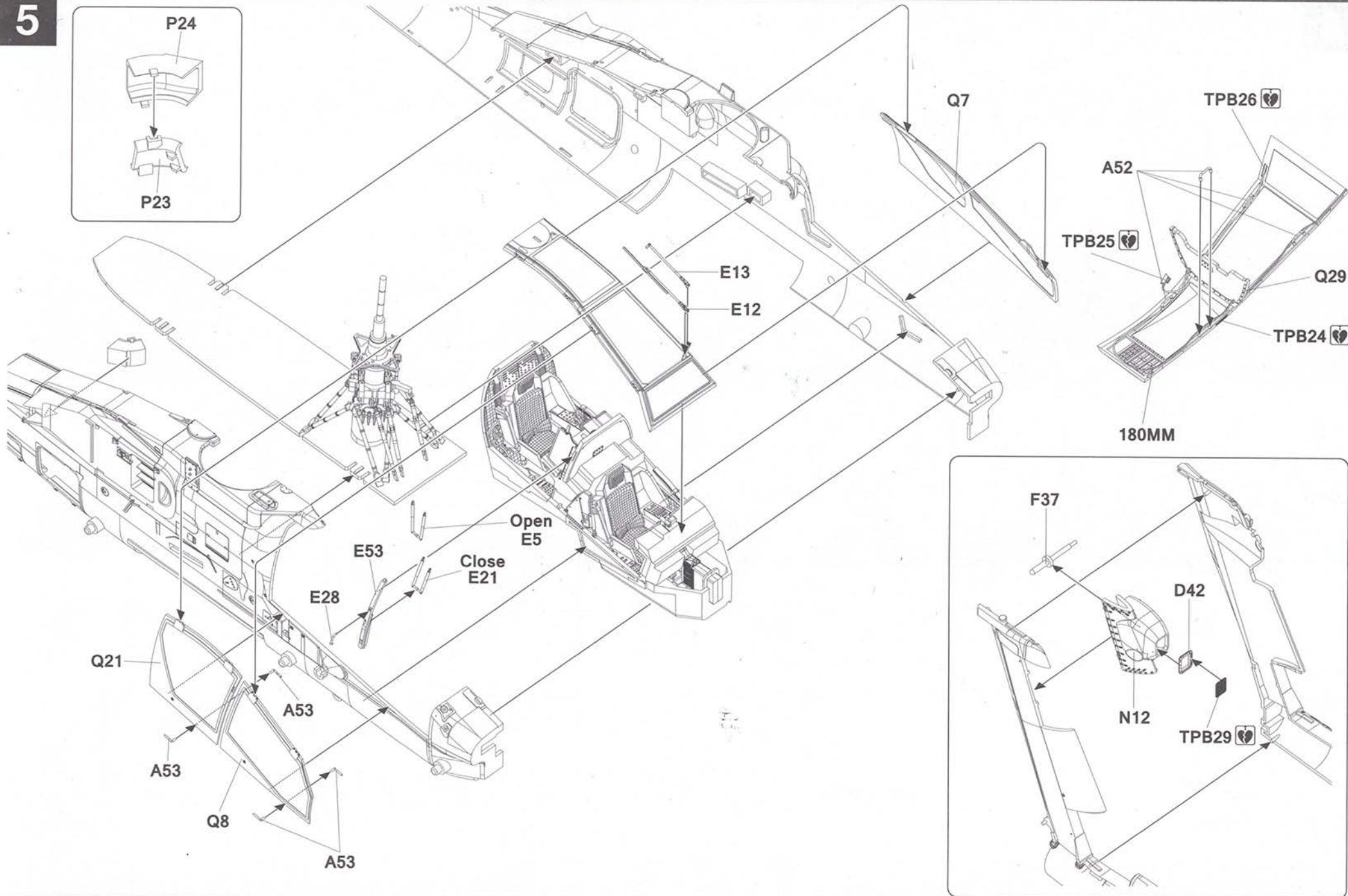

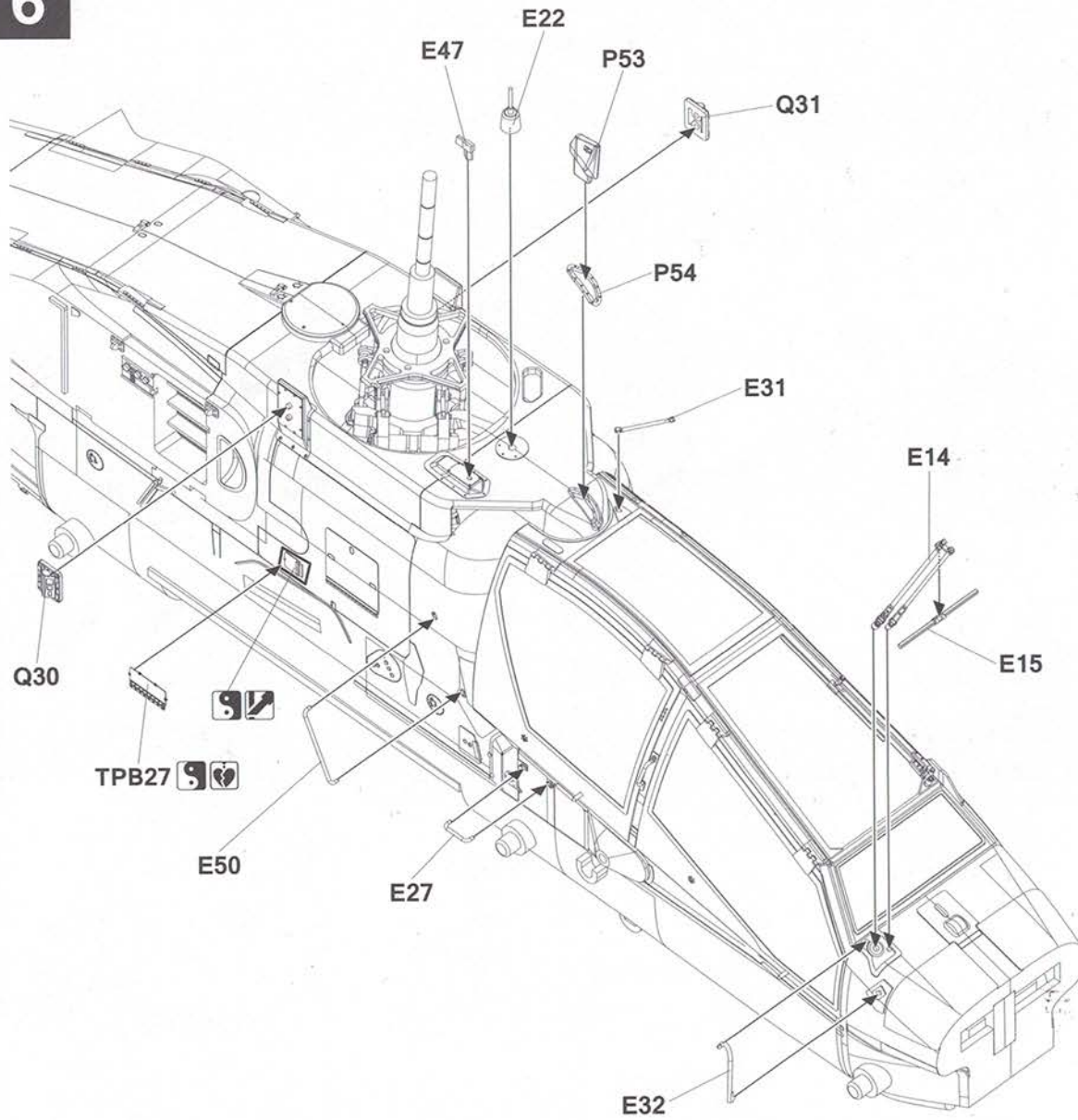
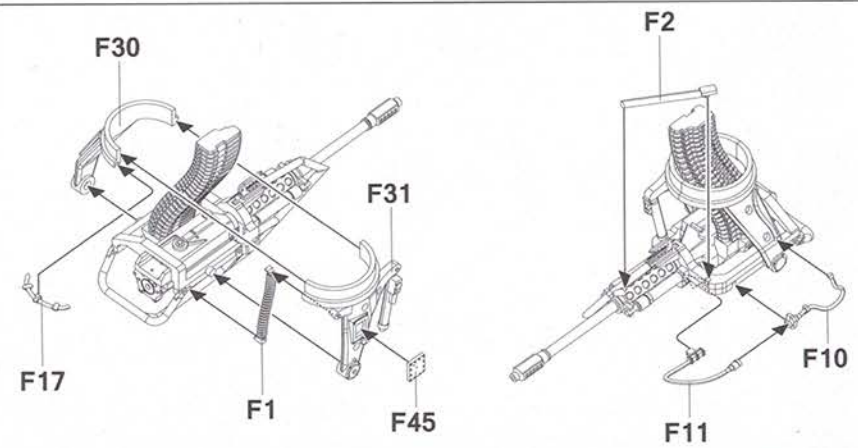
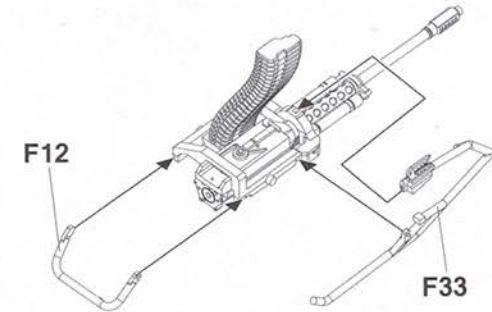
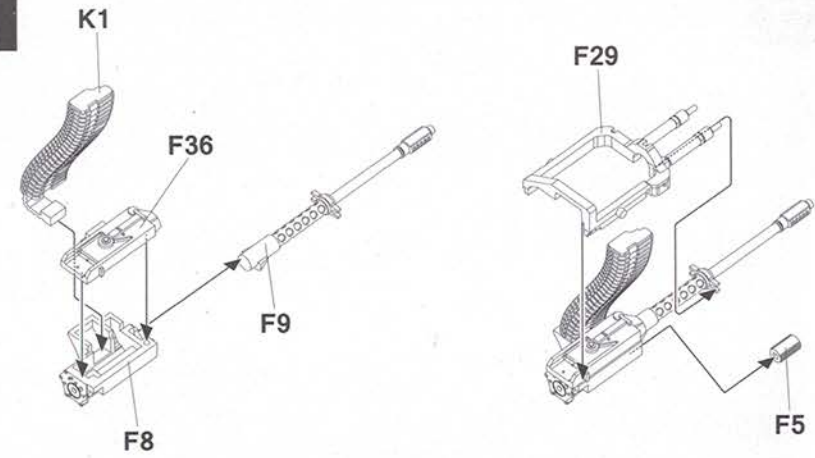
**6****7**



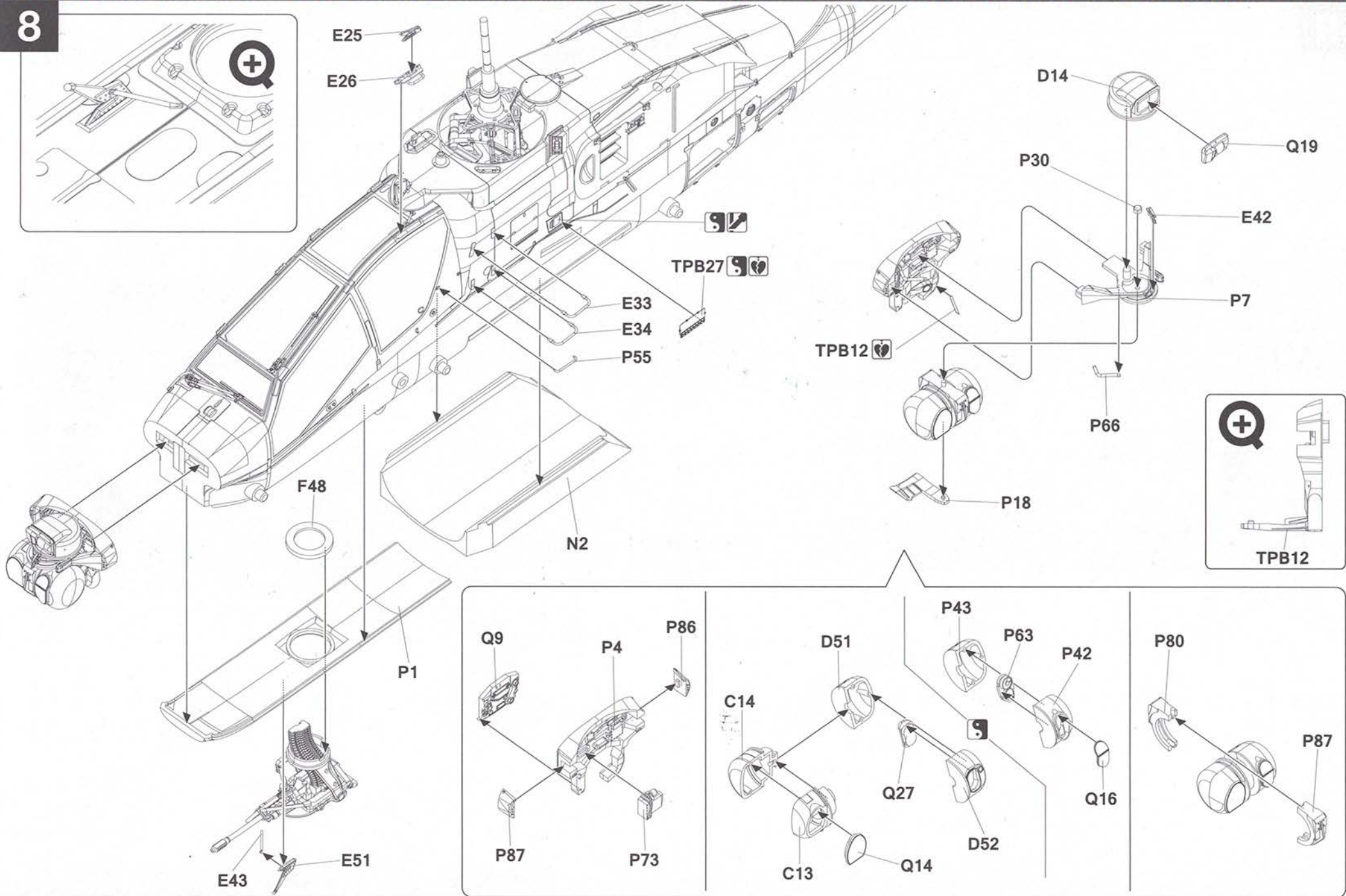

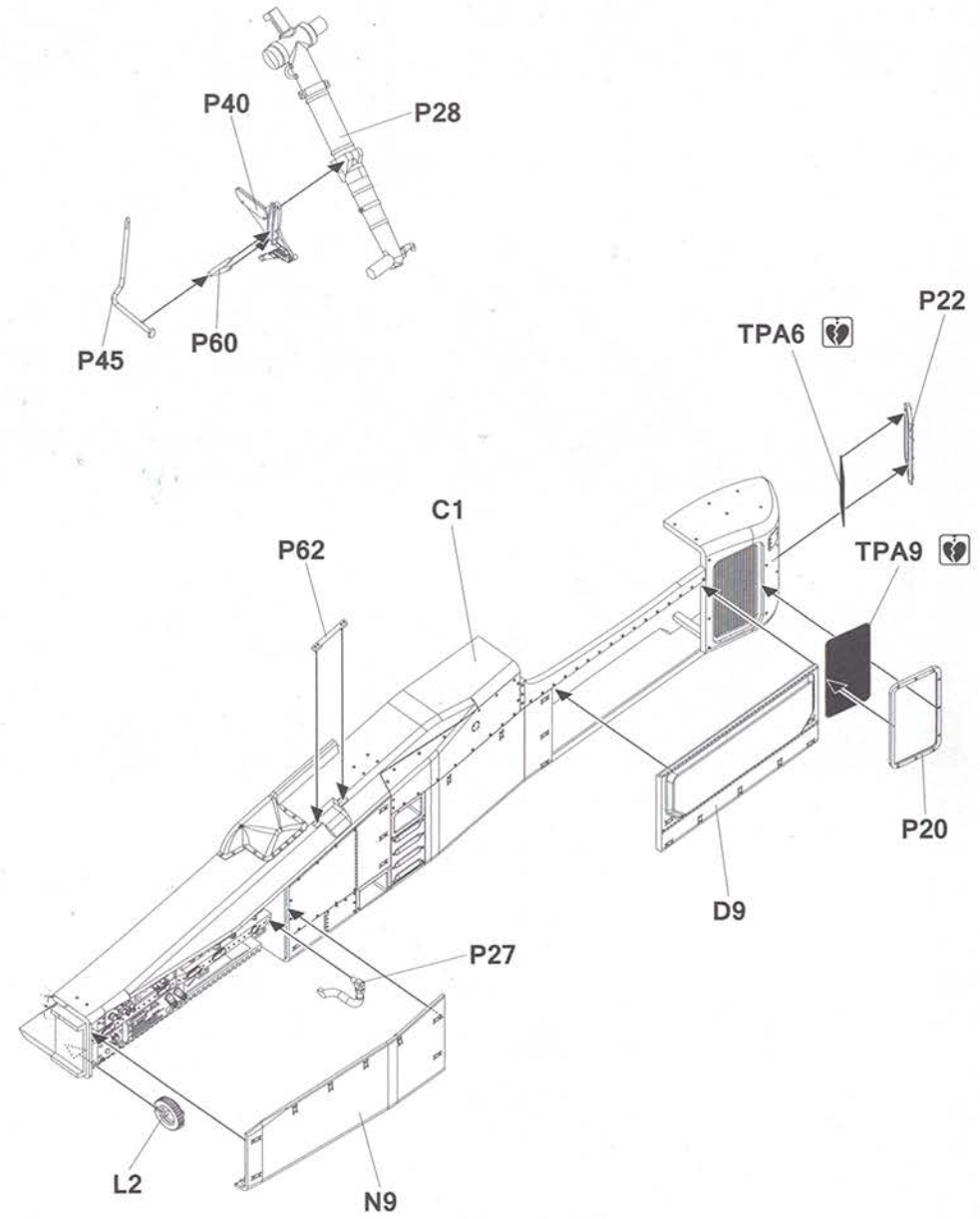
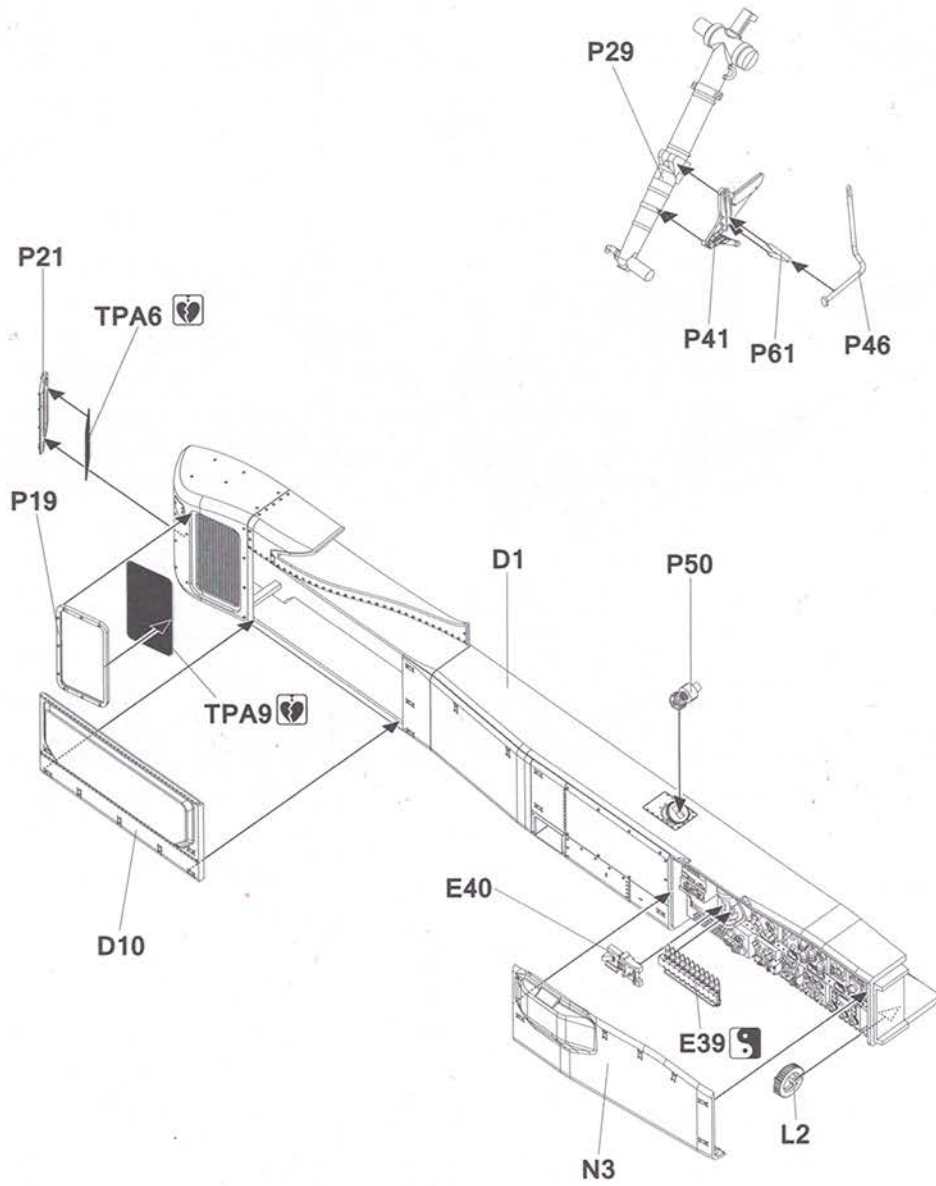

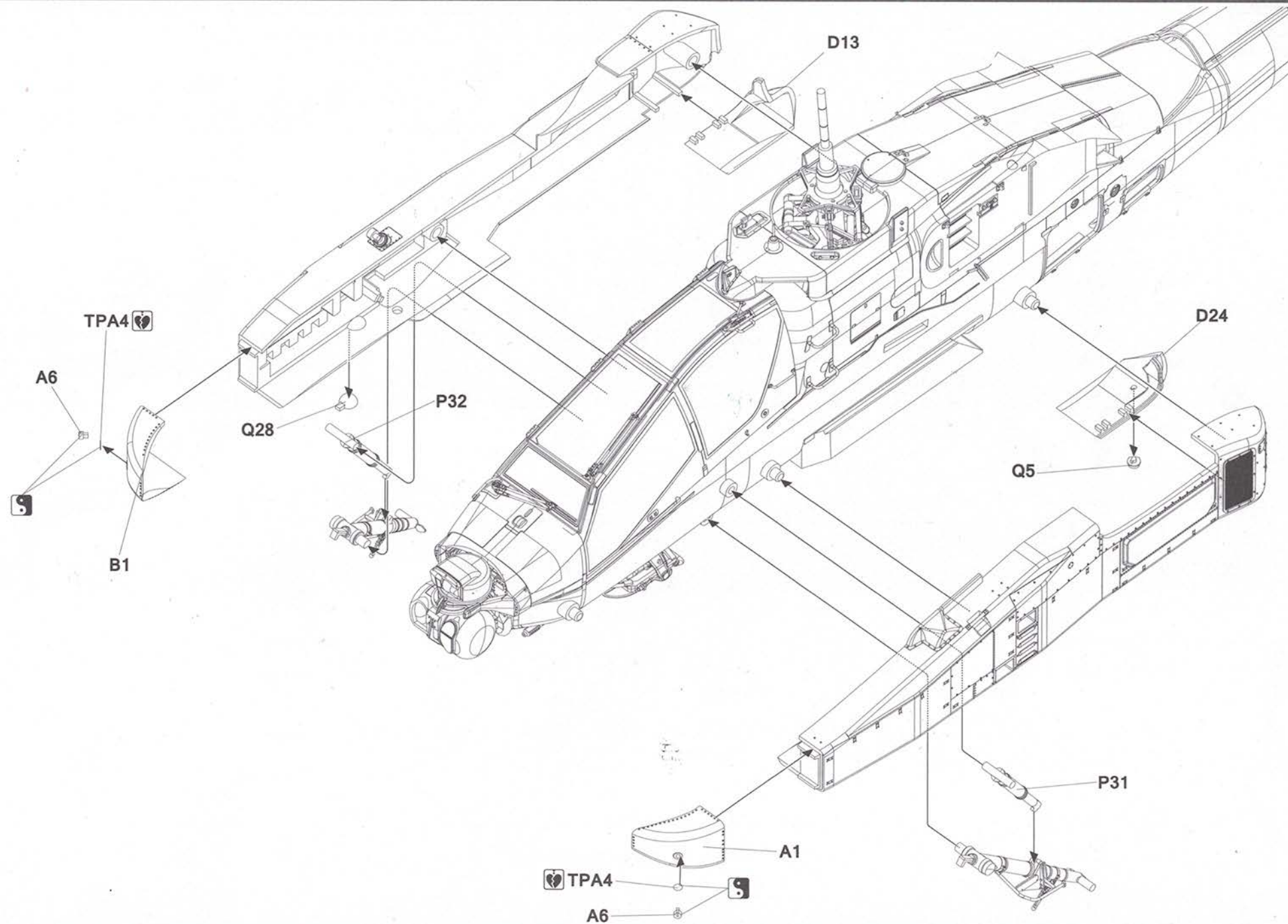

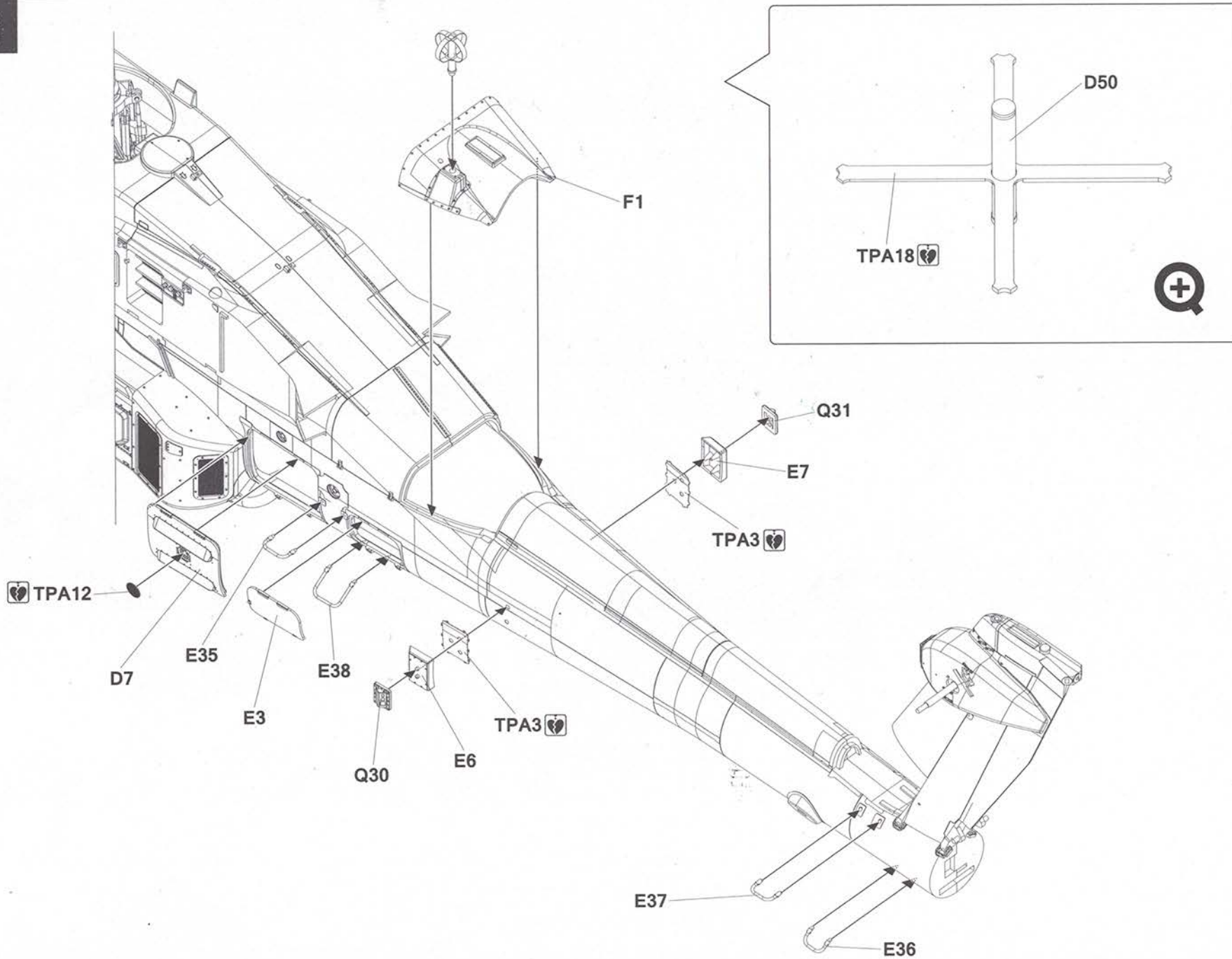

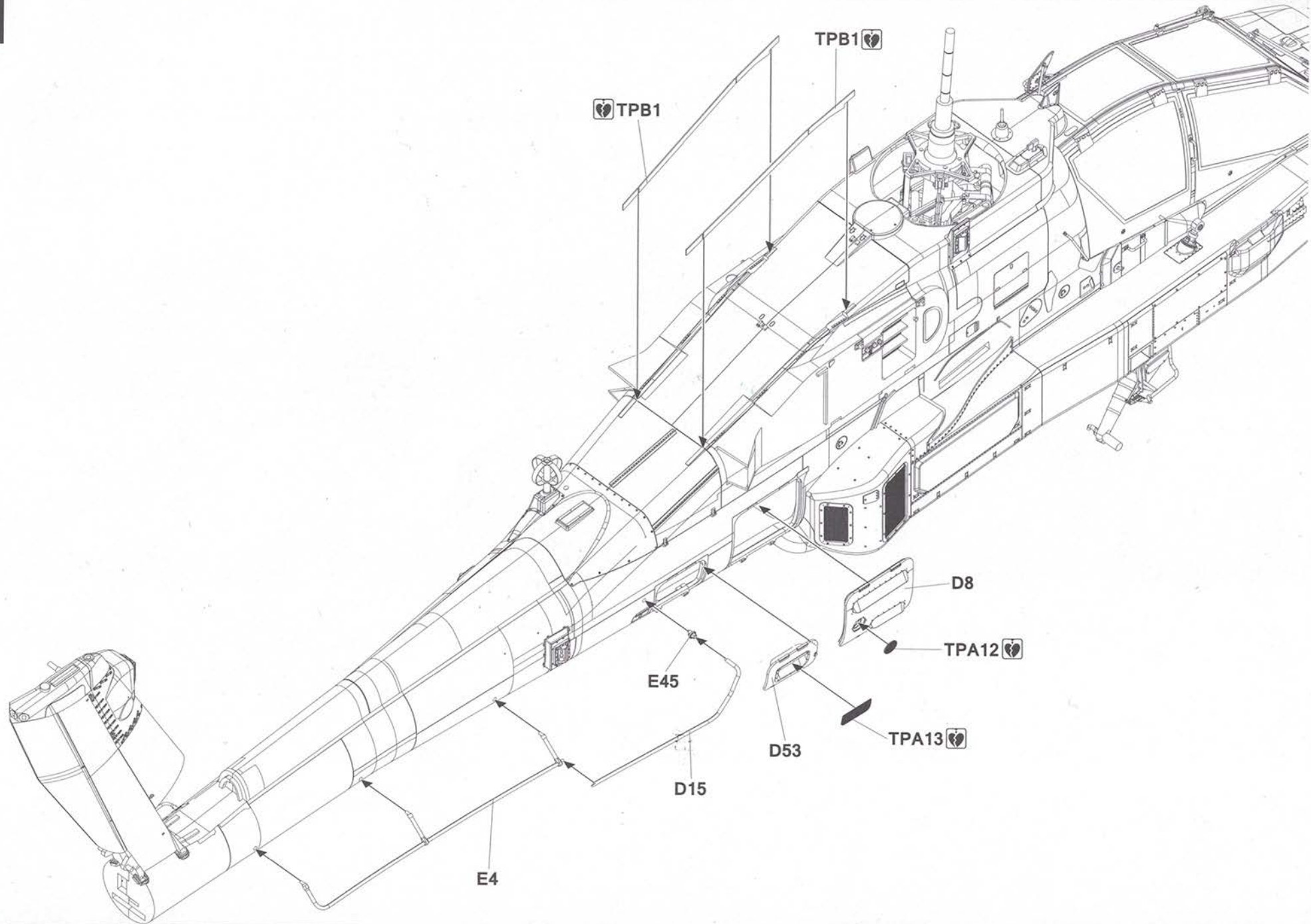

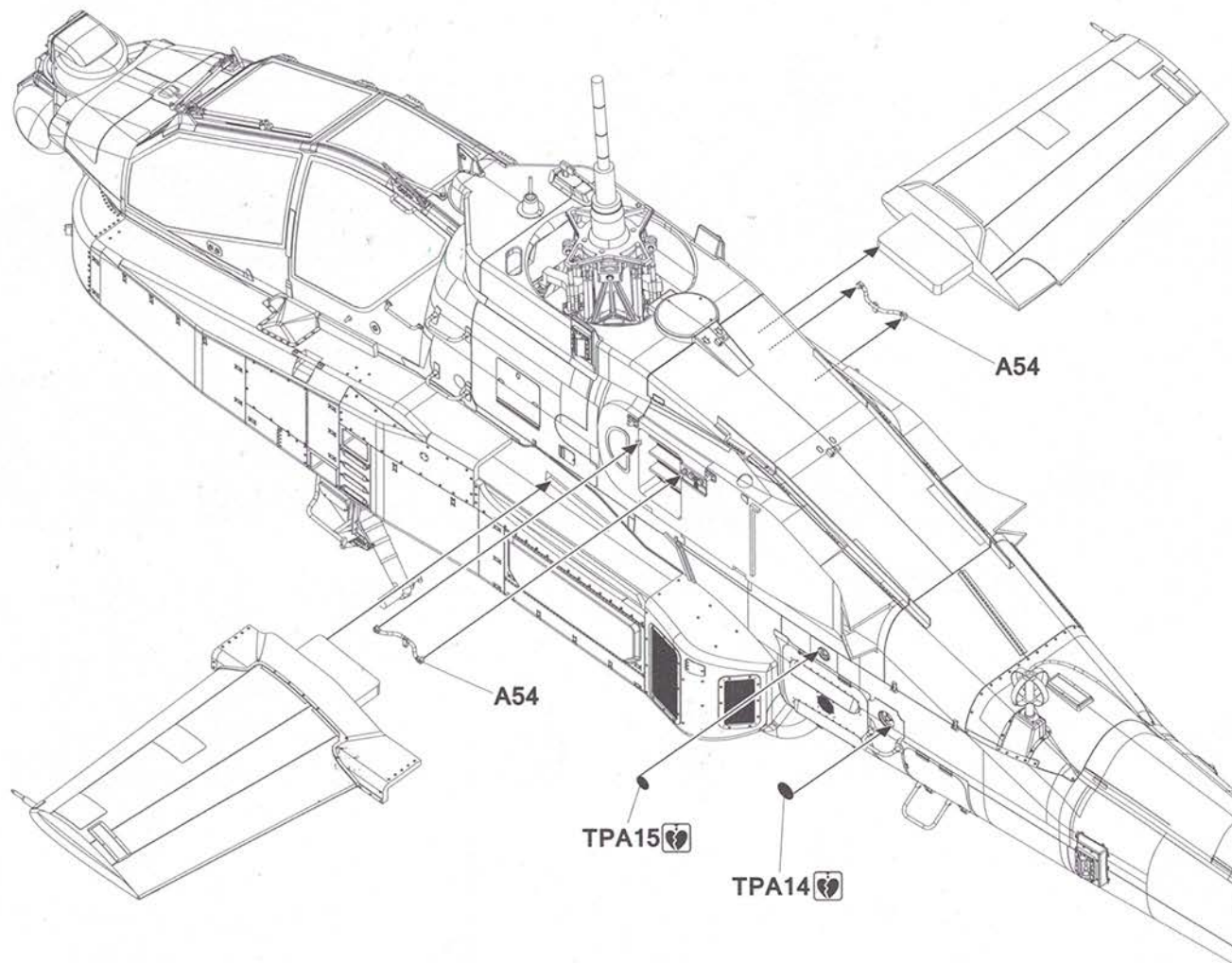
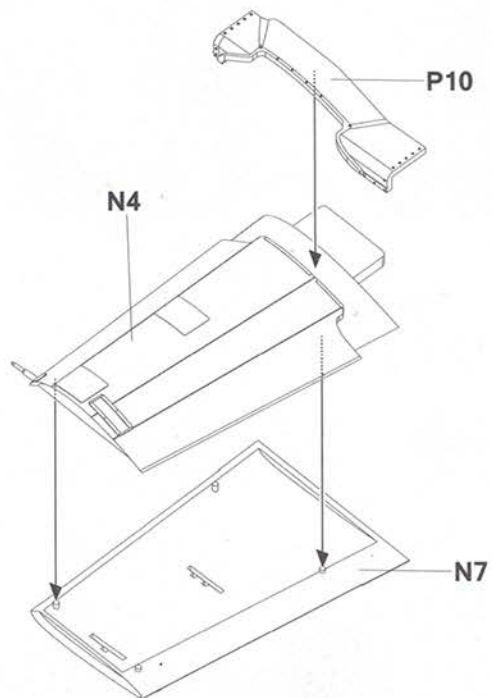
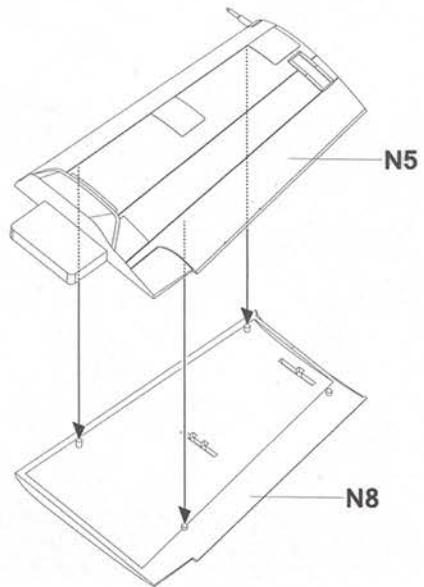

15

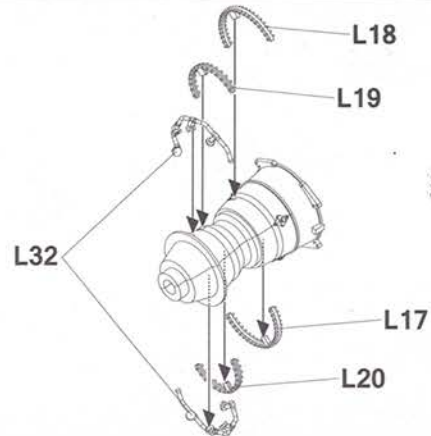
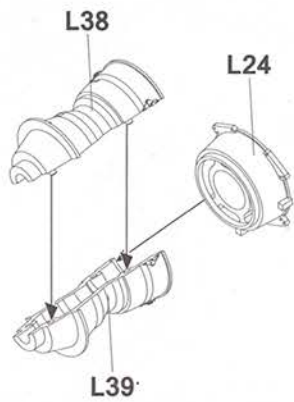
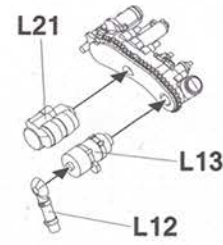
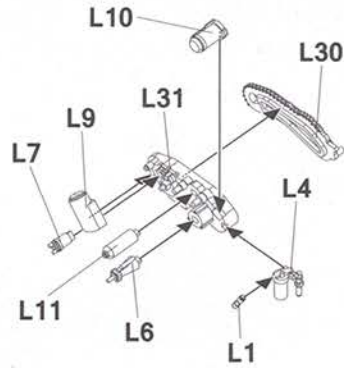
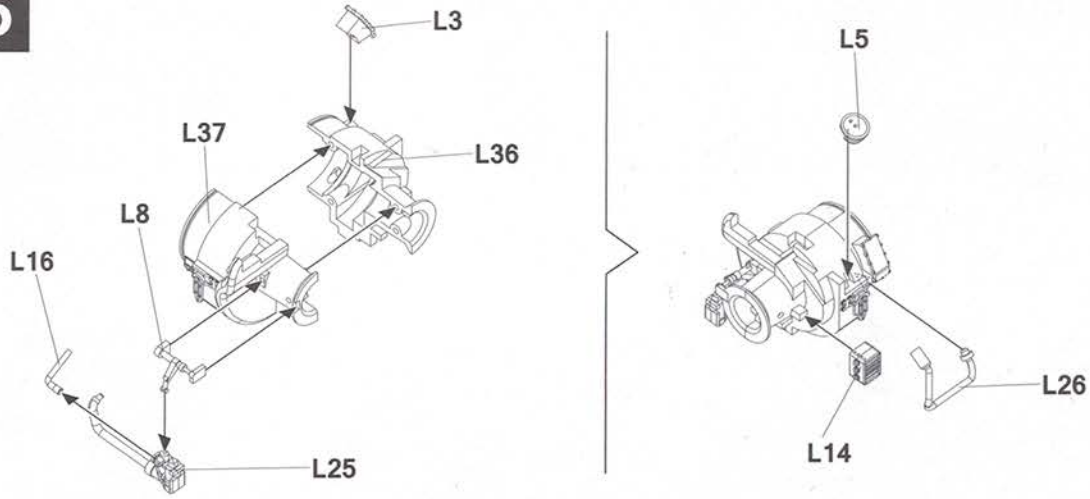

16

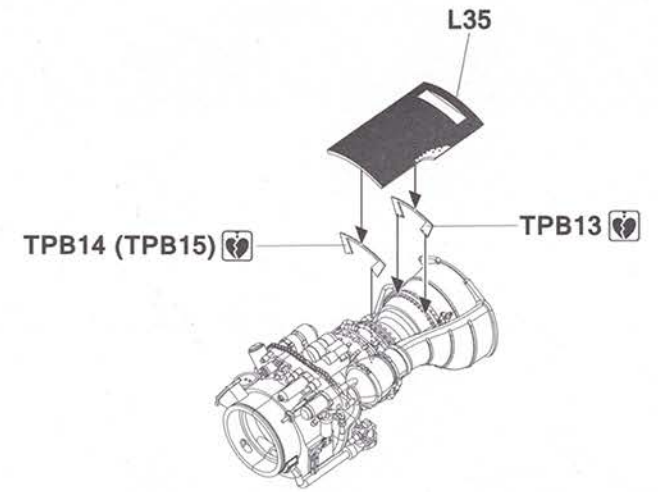
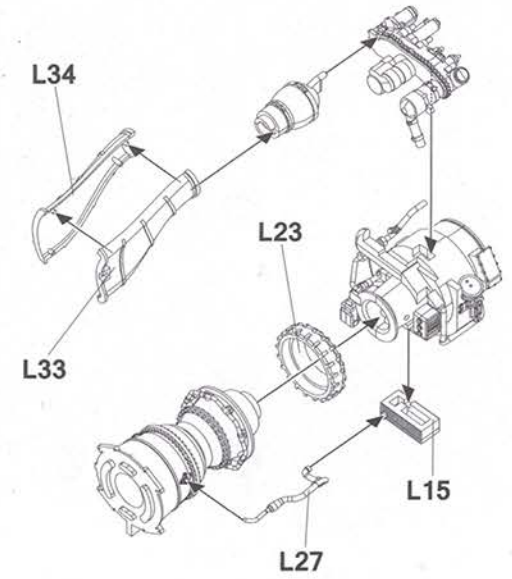

Make 2

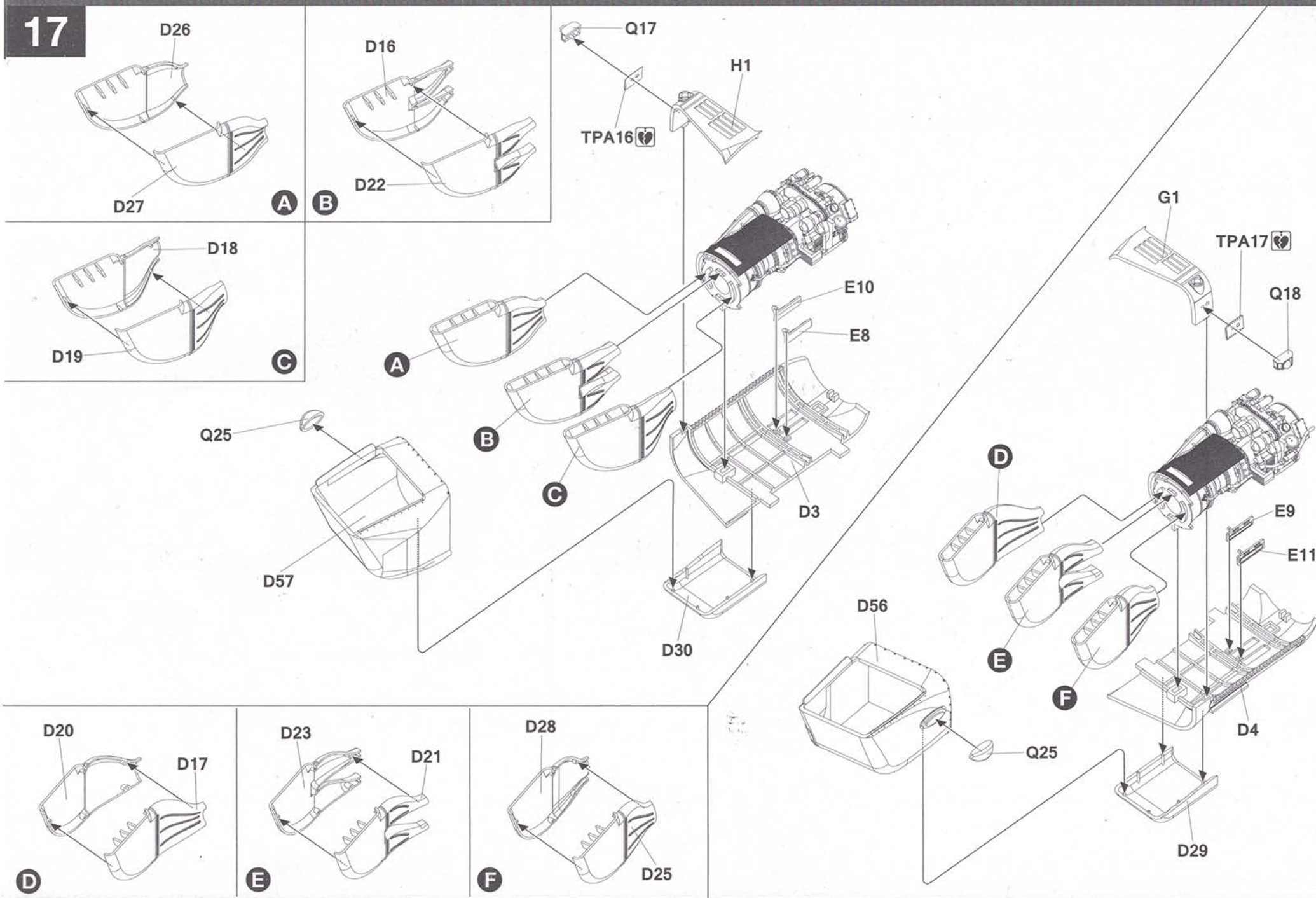



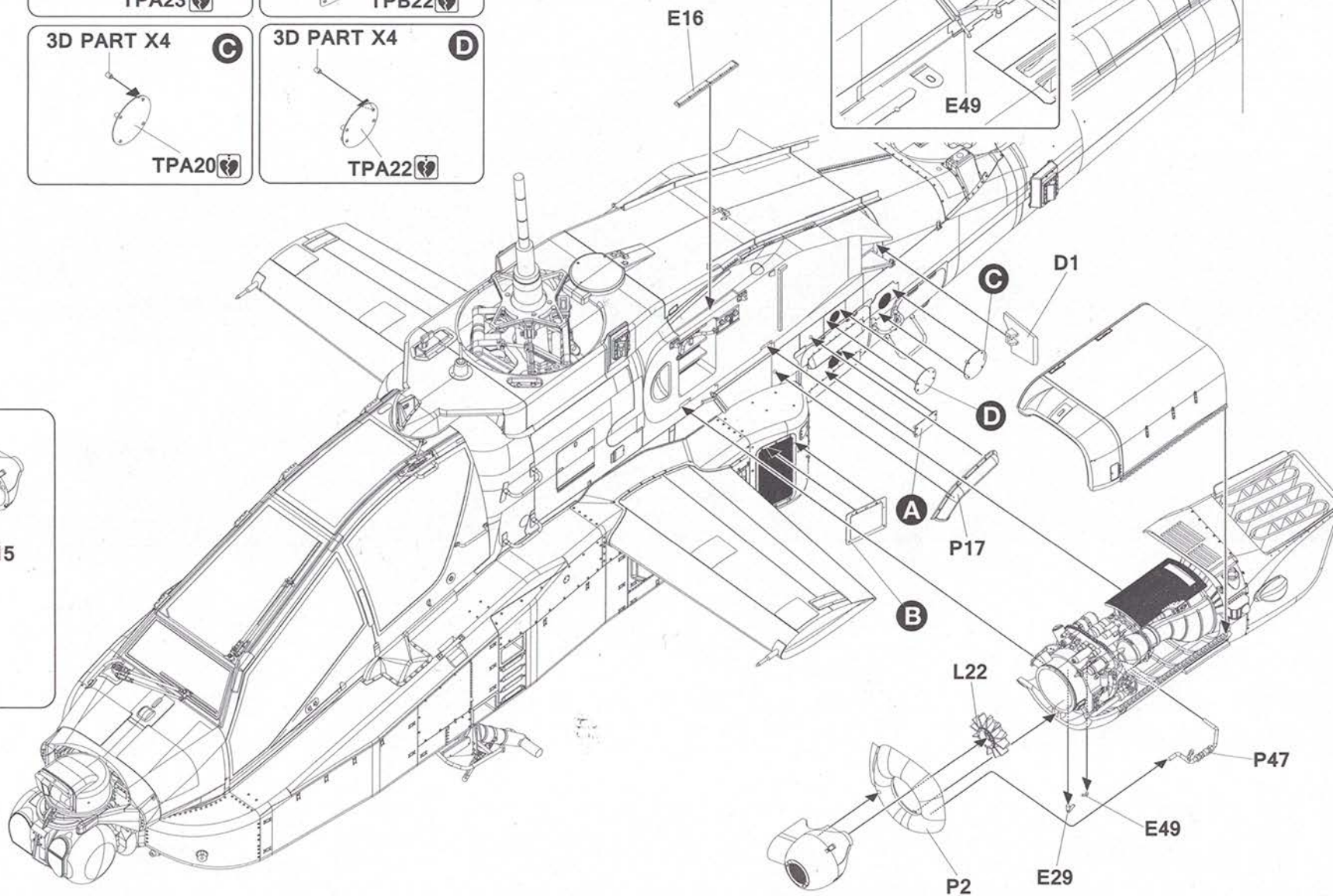
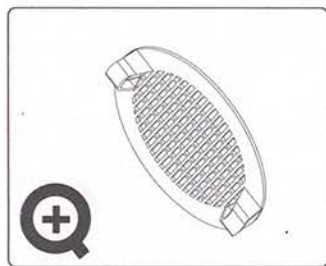
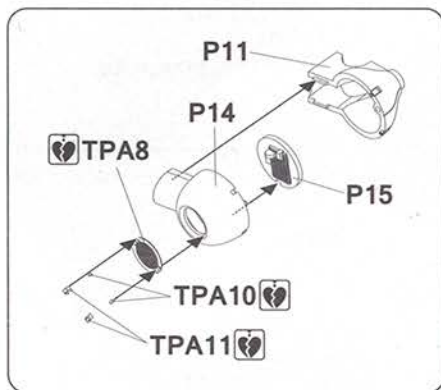
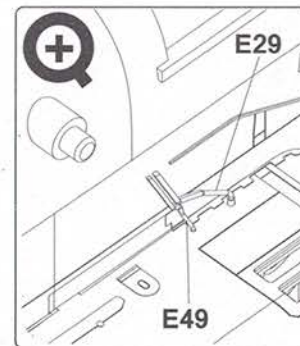
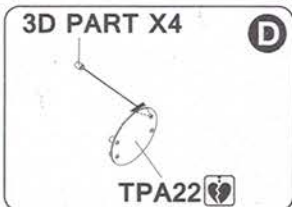
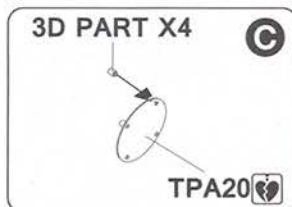
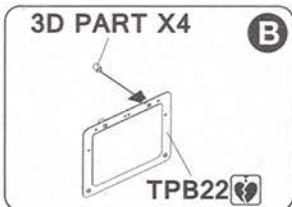
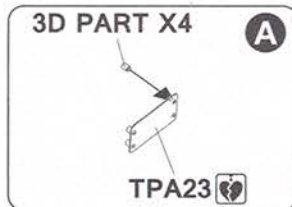
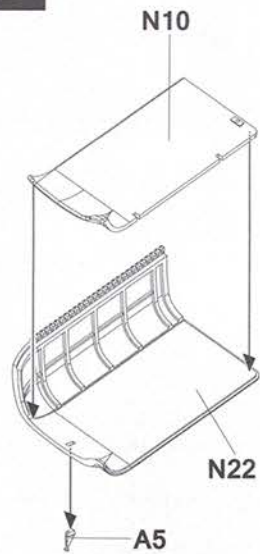

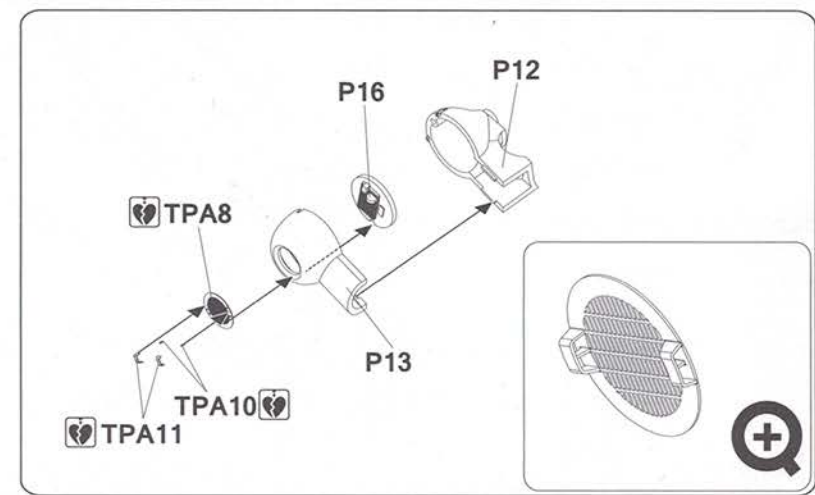
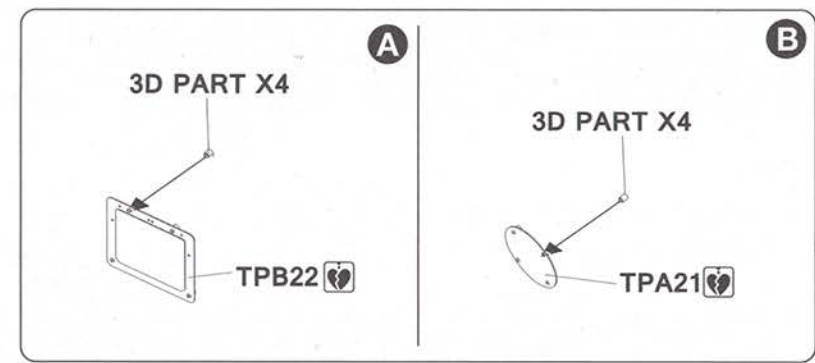
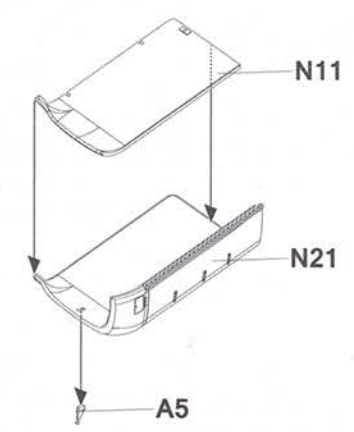
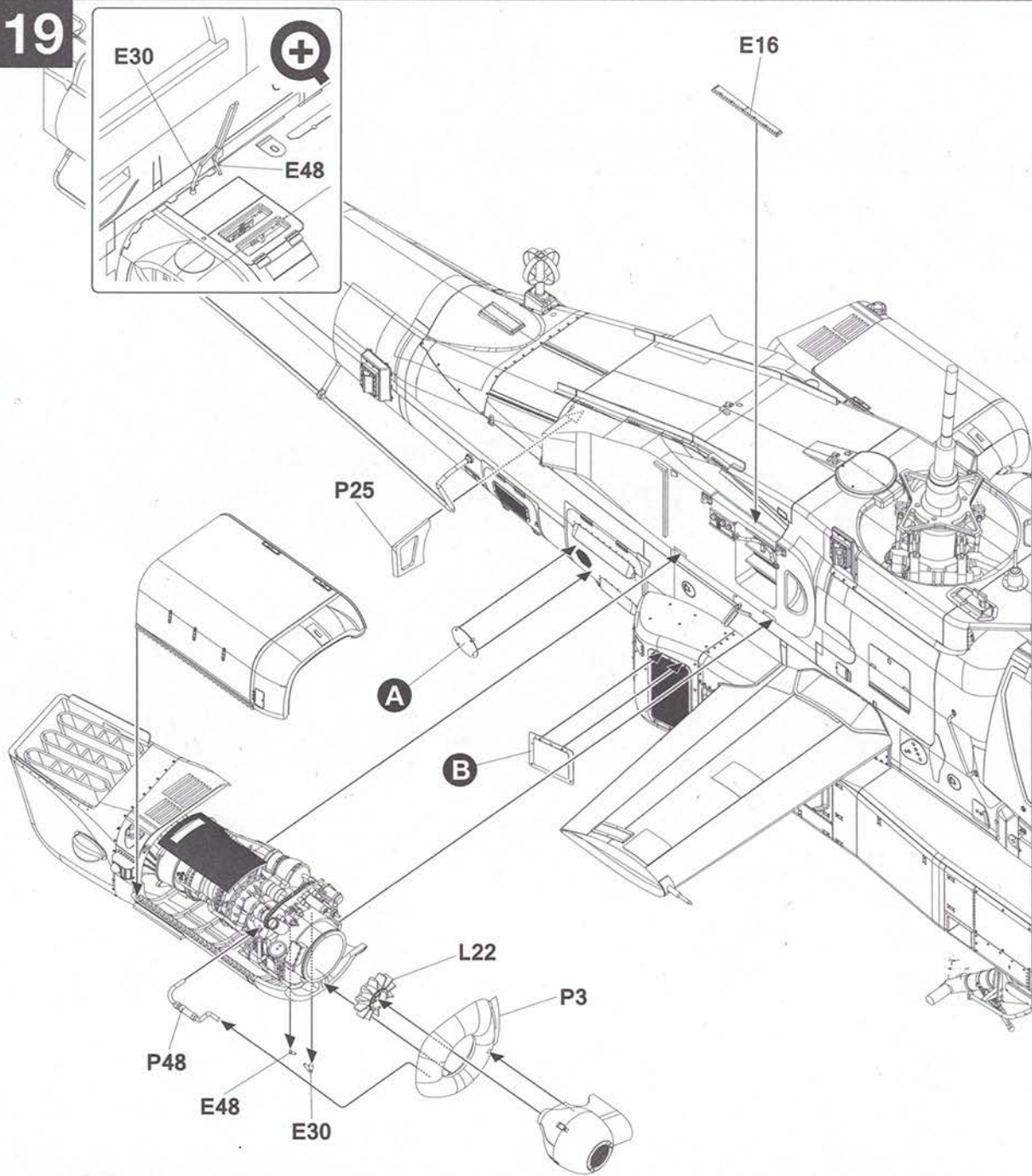

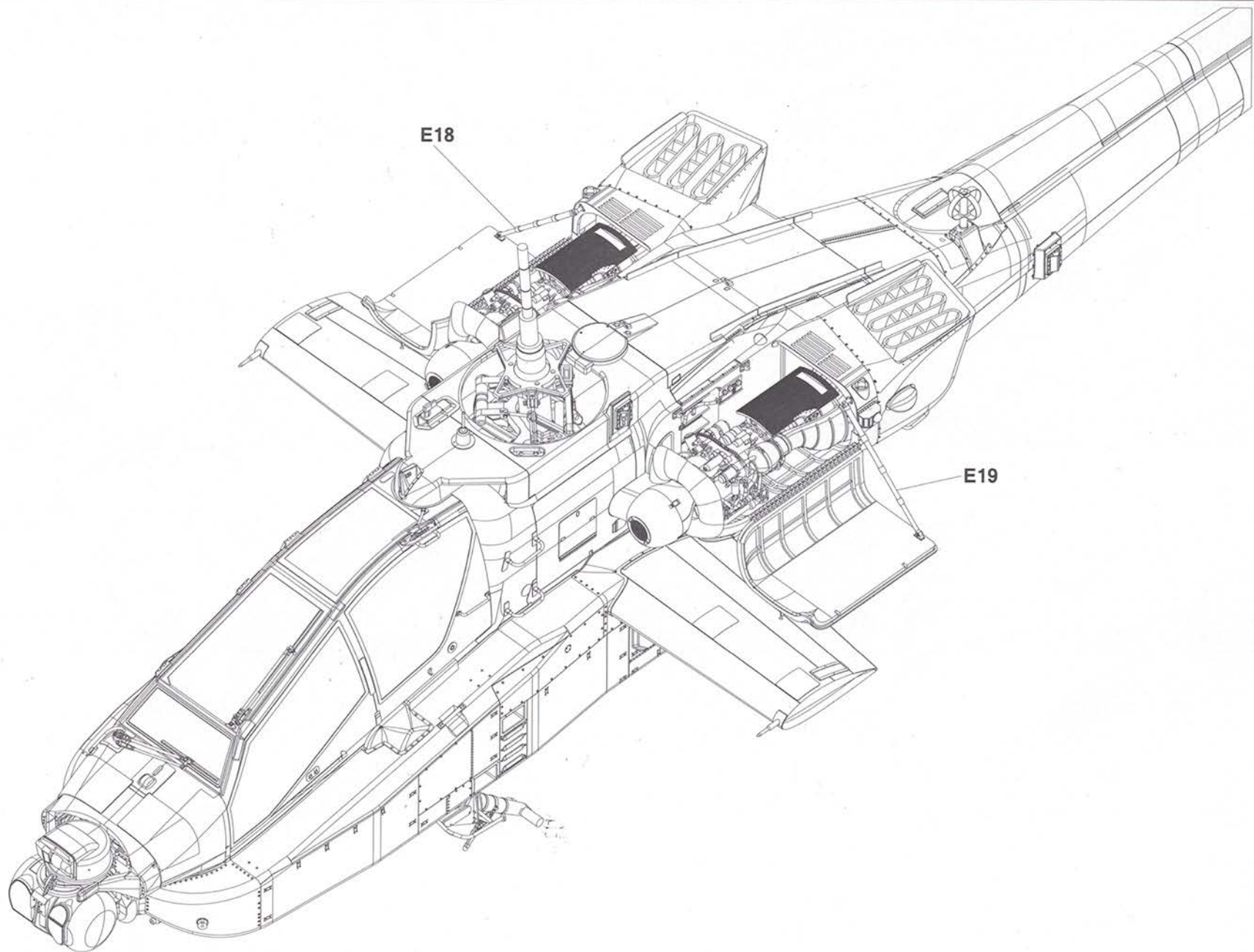

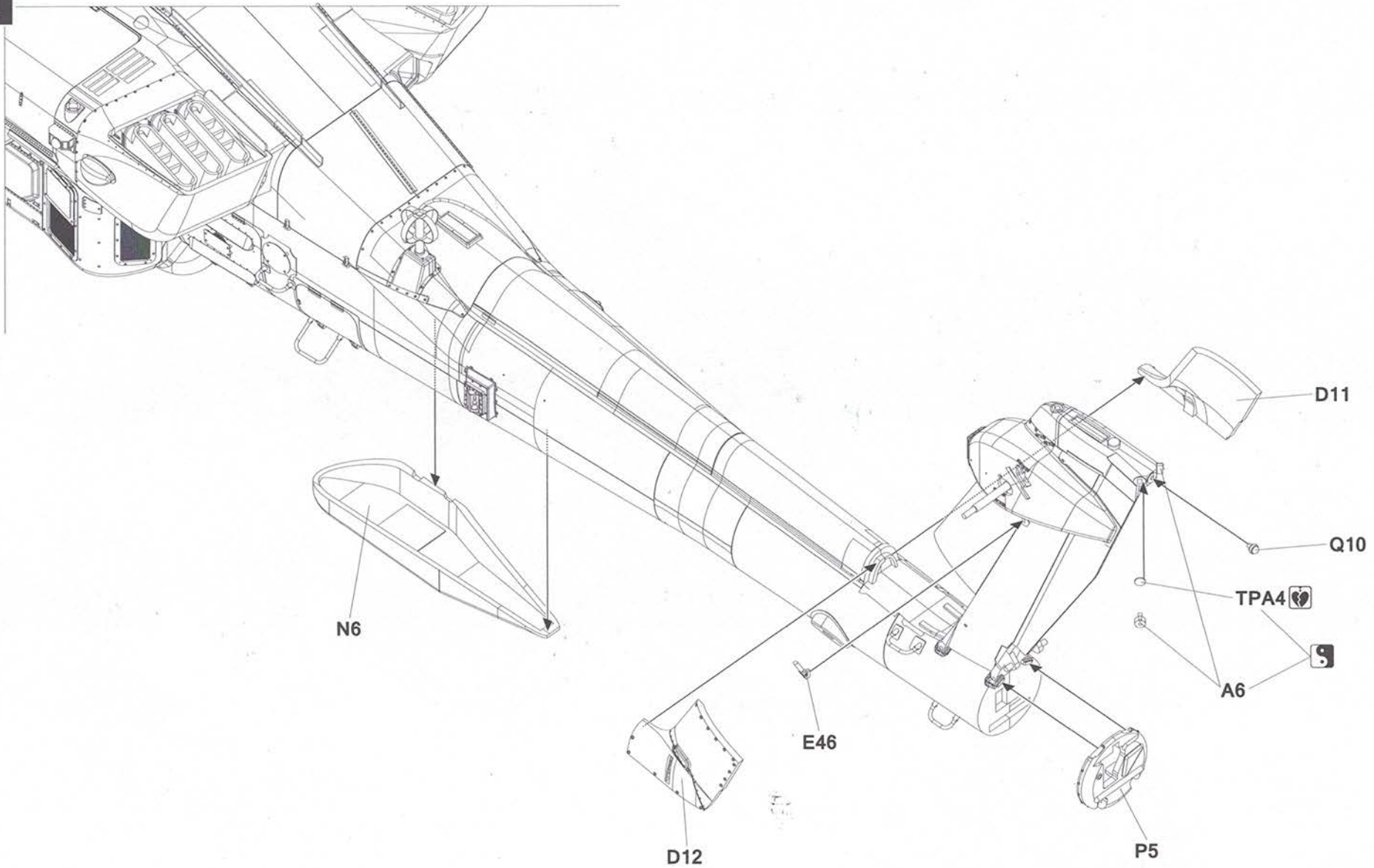

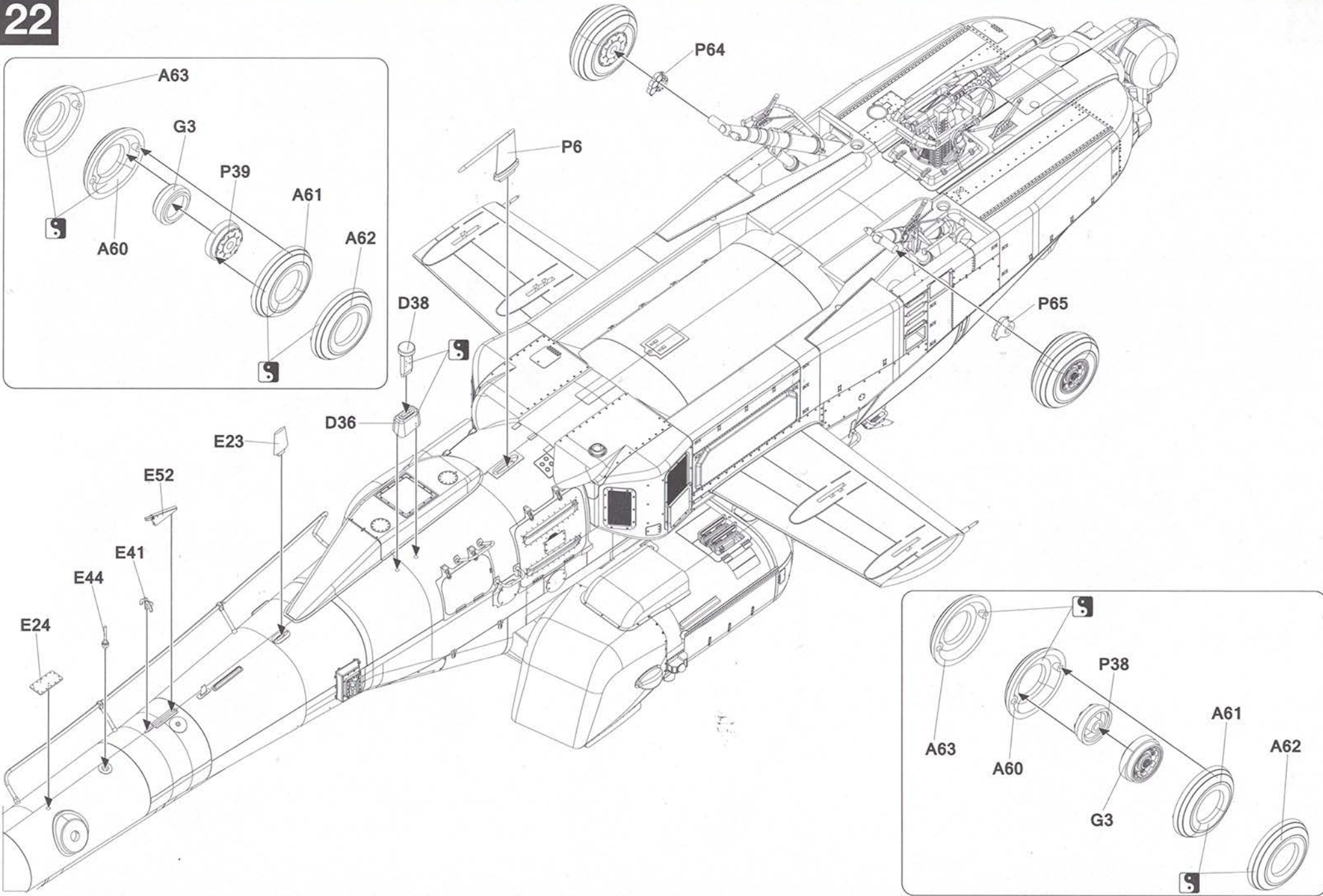

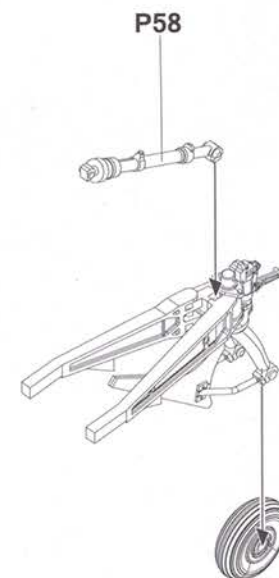
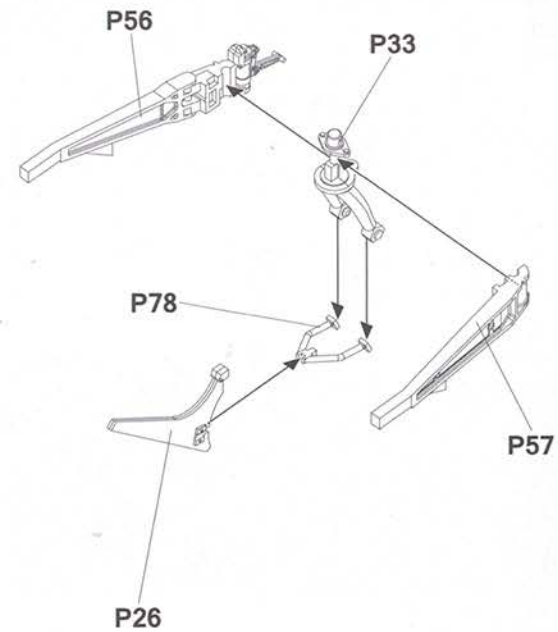
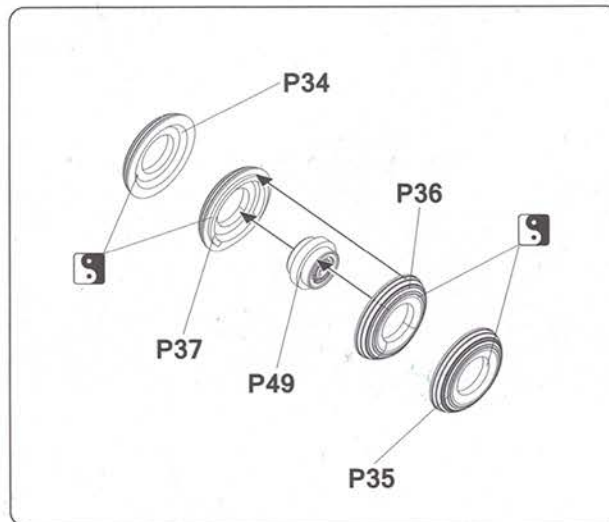
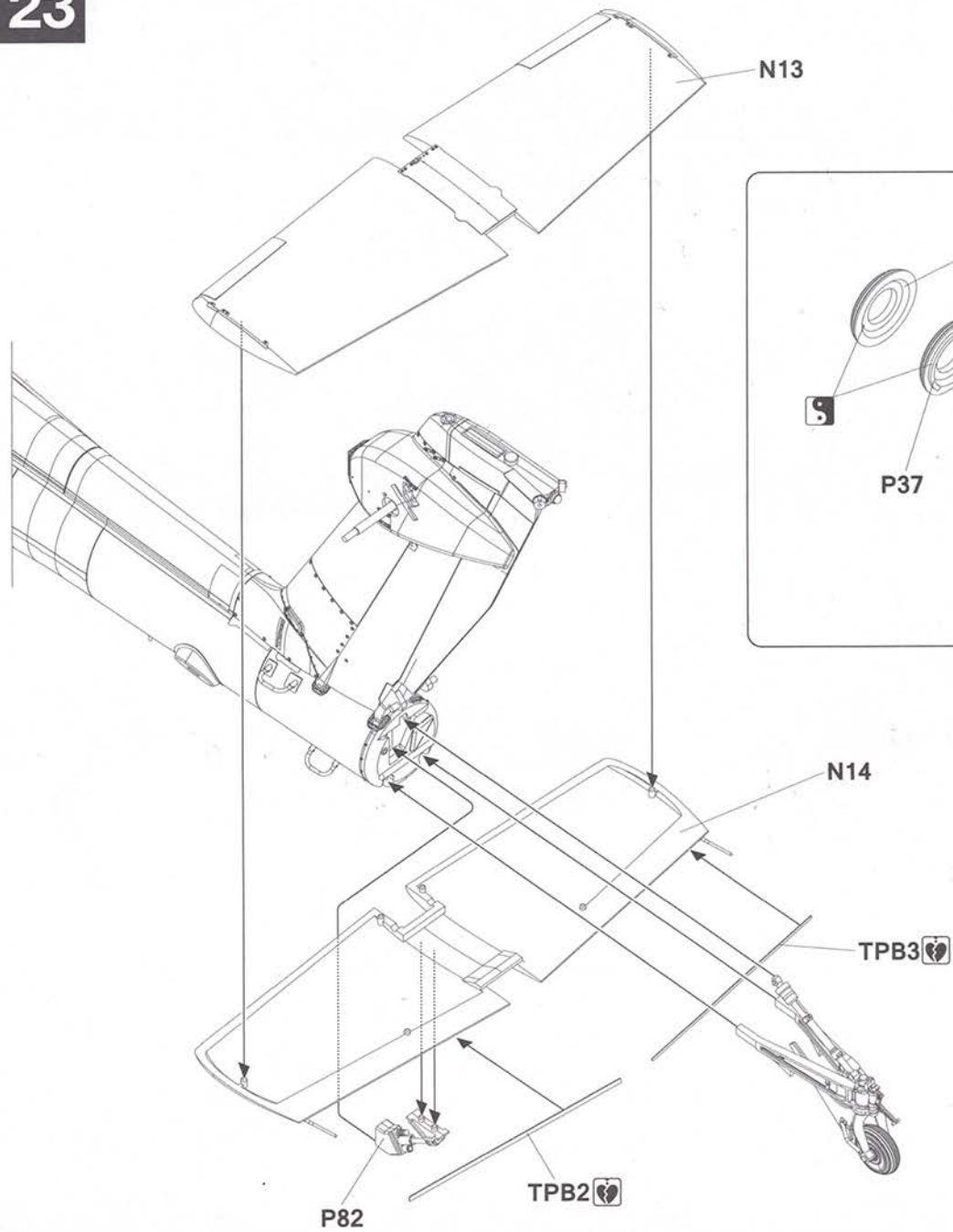

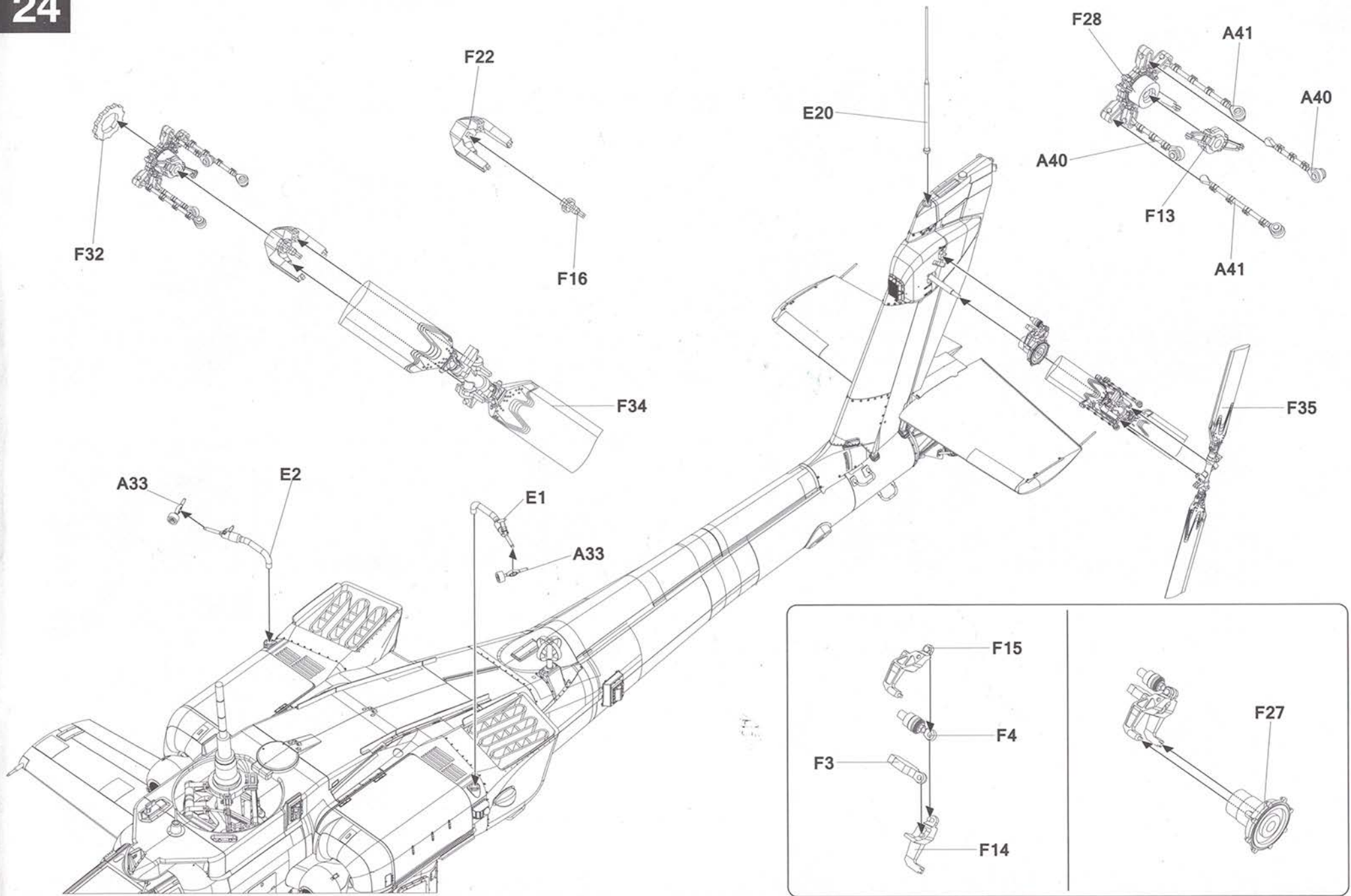

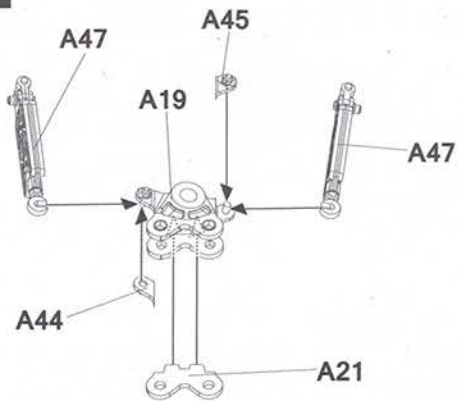

**Make 4**

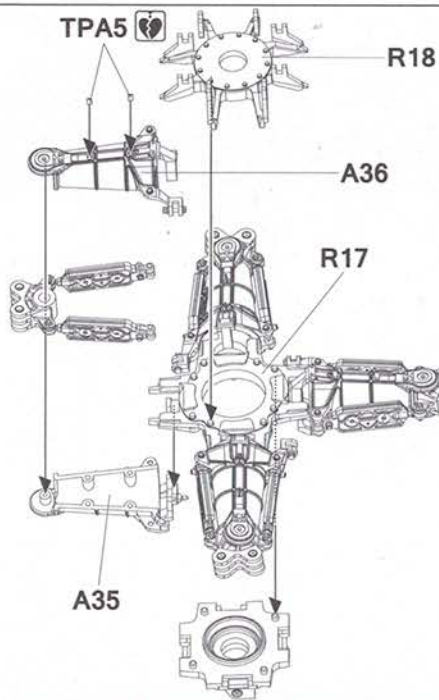
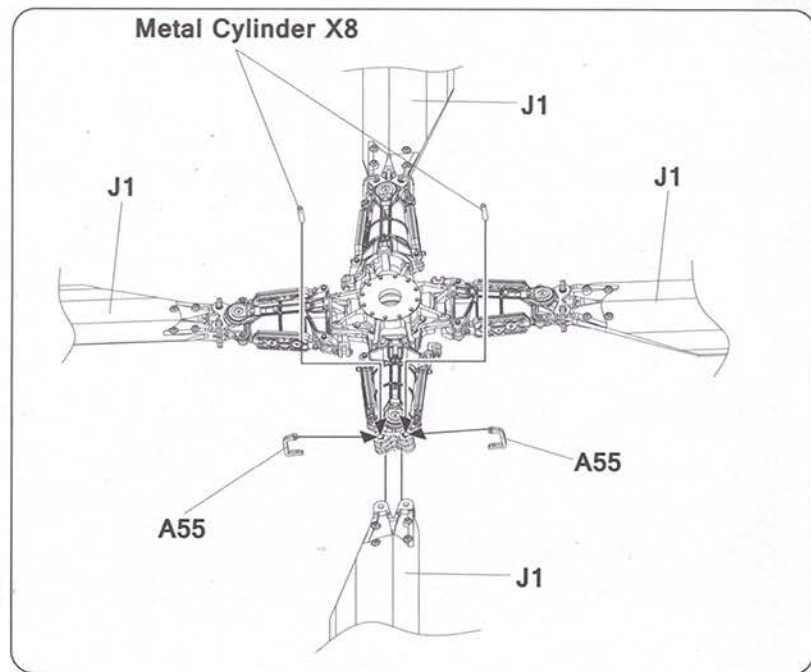
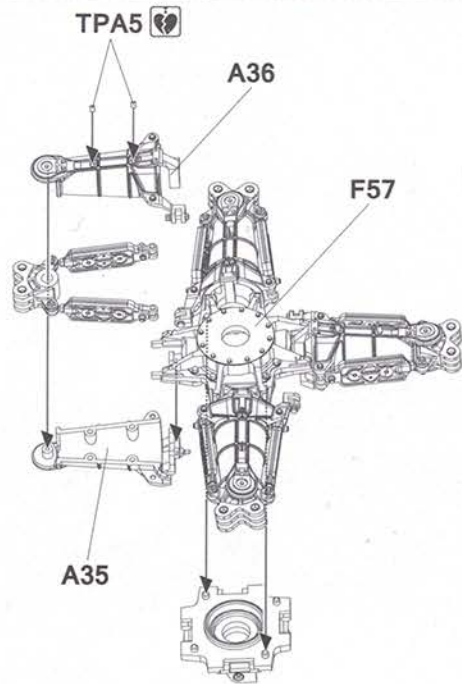
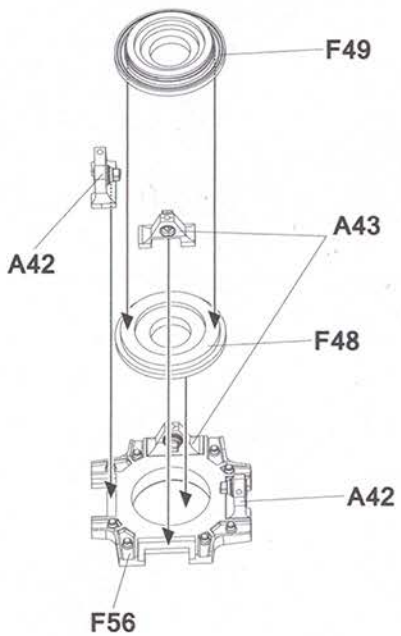

9

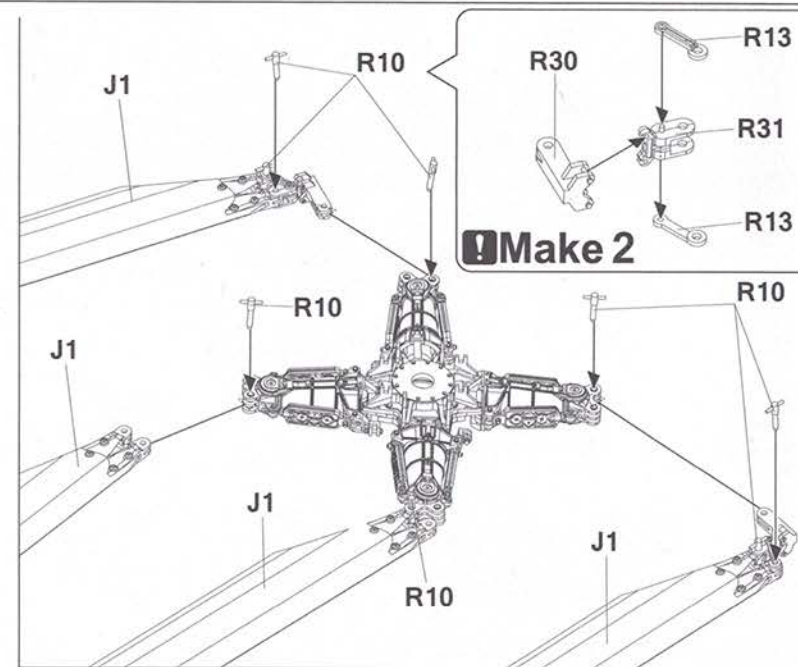



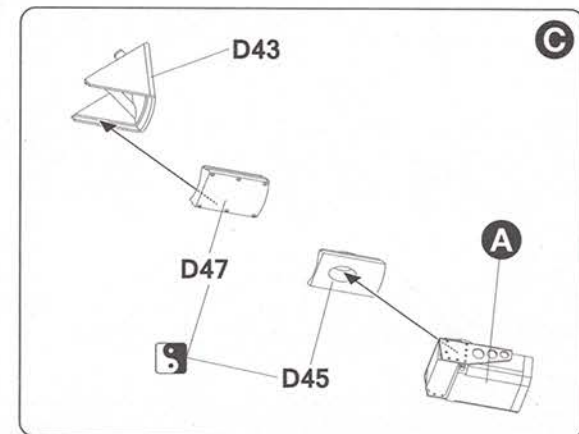
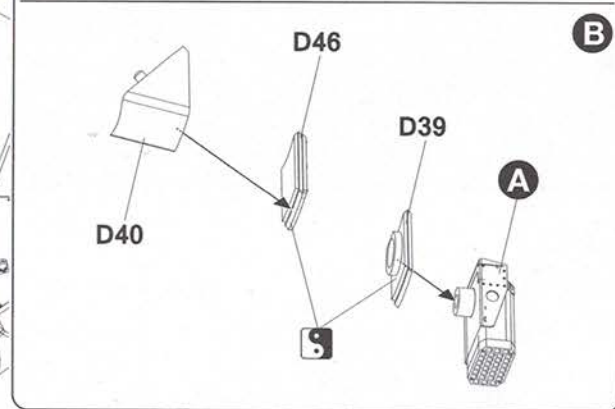
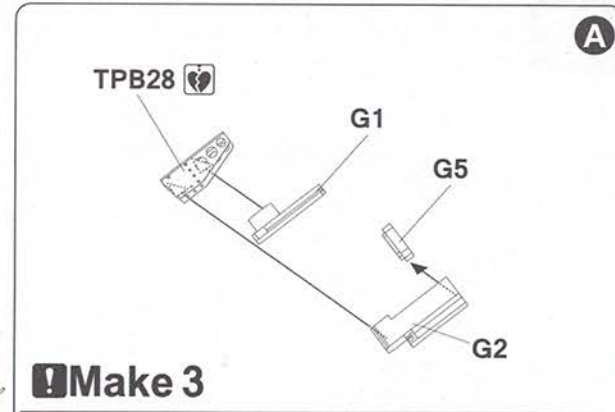
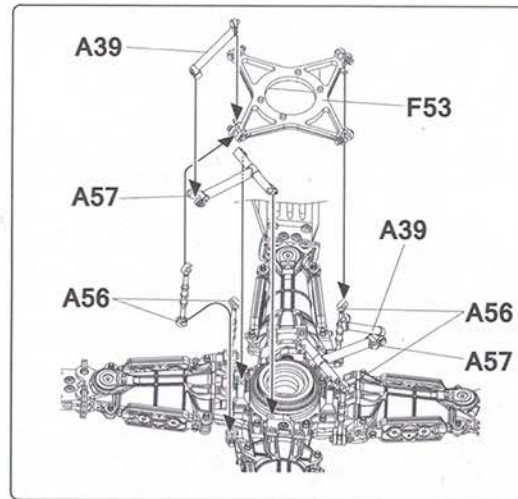
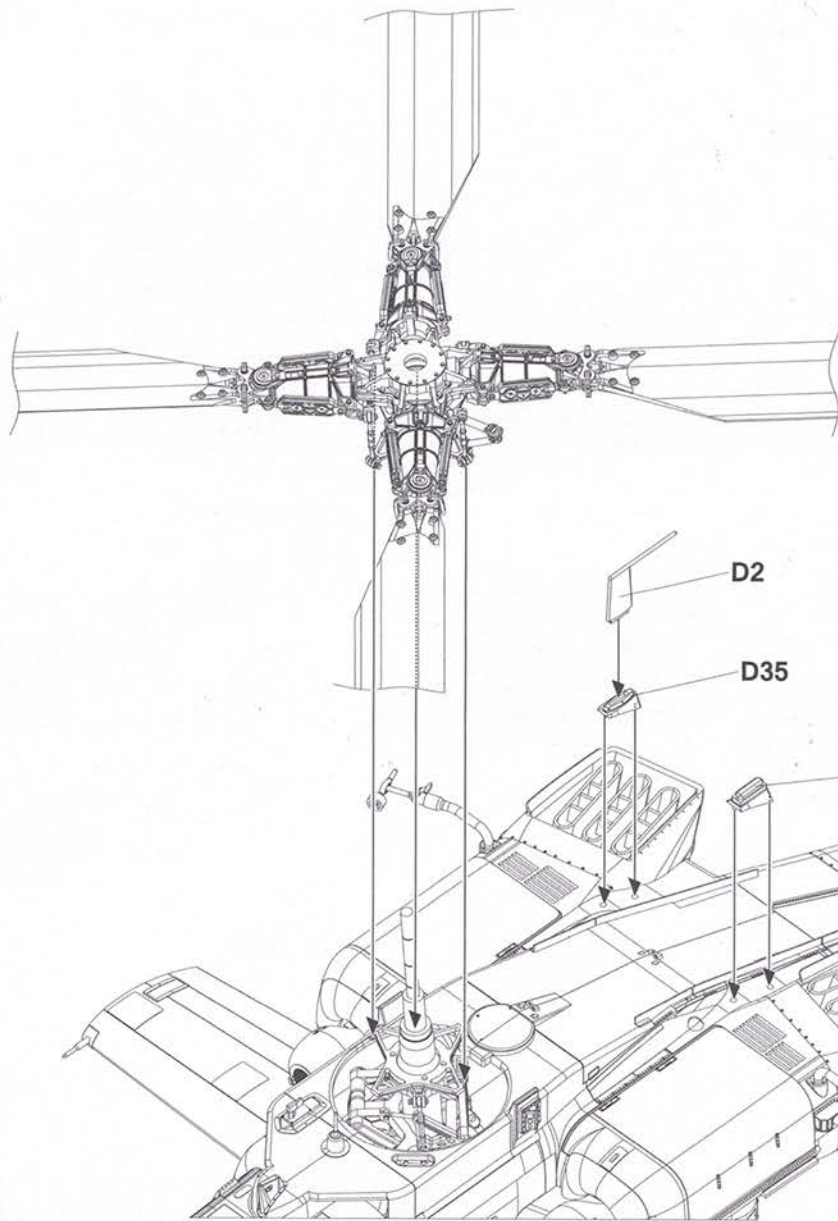

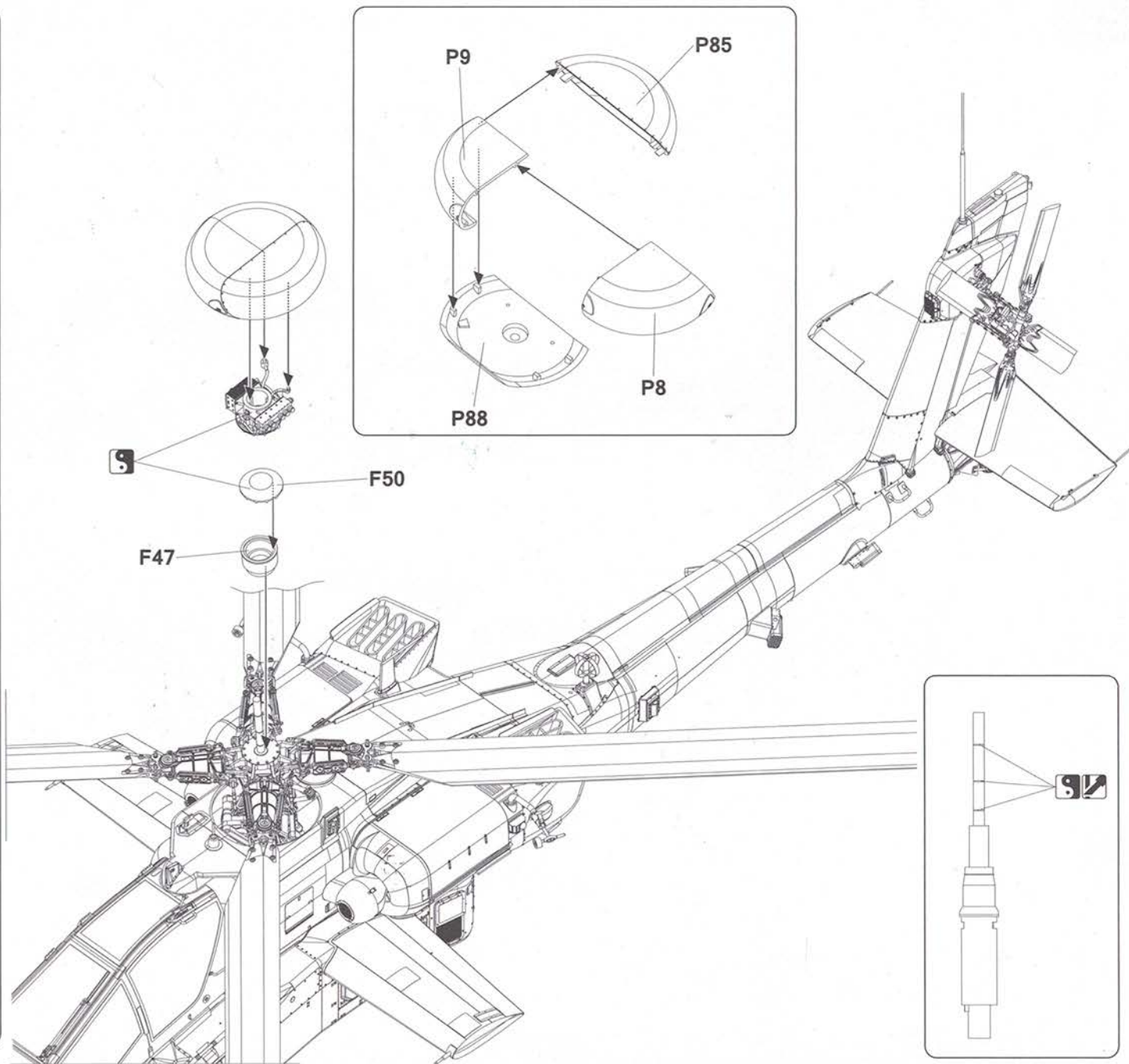
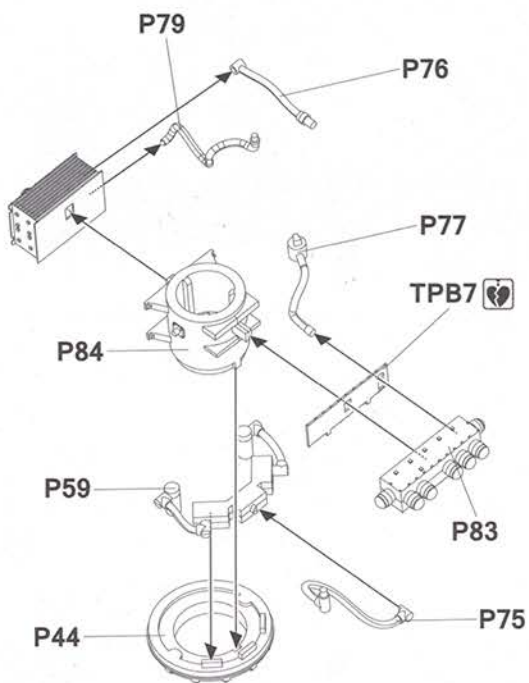
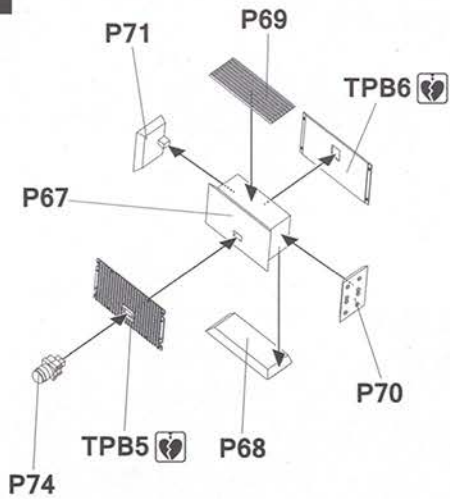

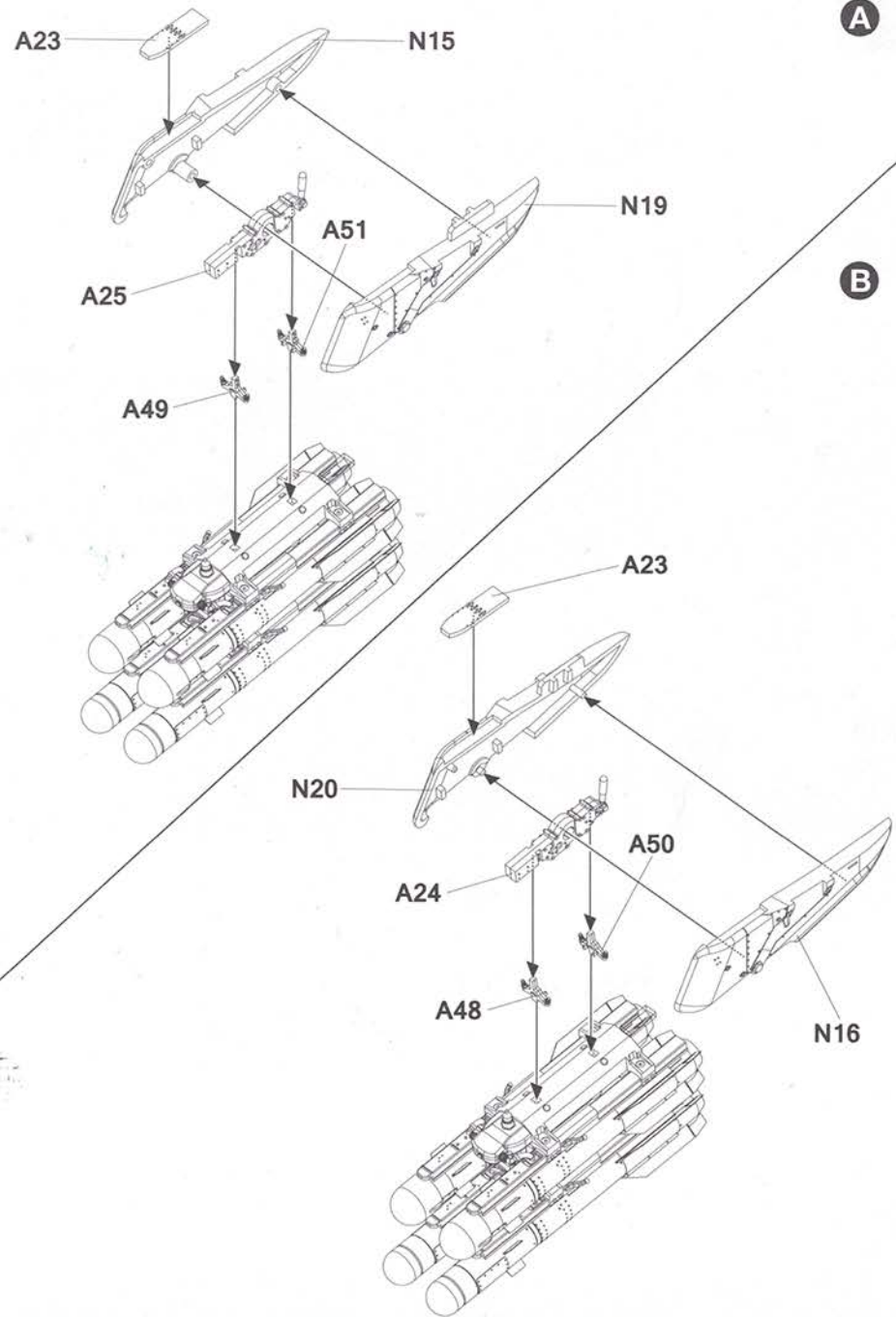
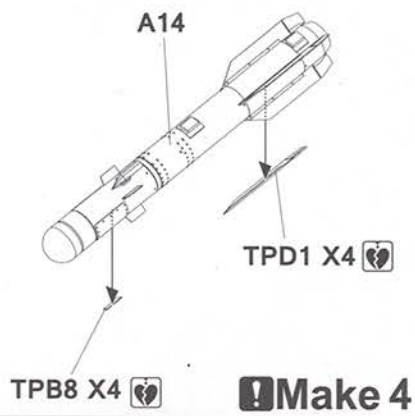
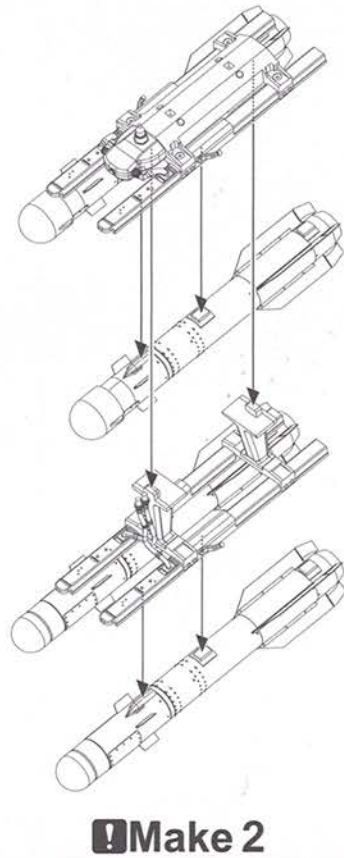
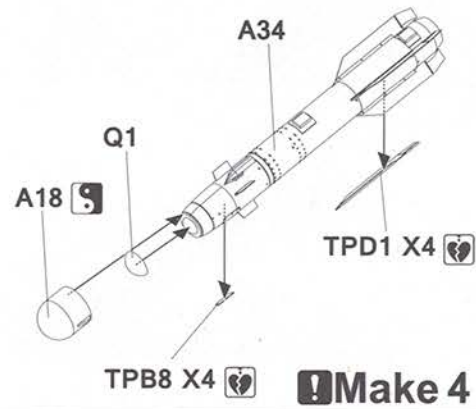
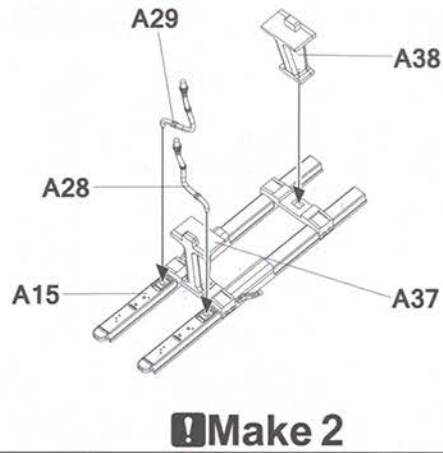
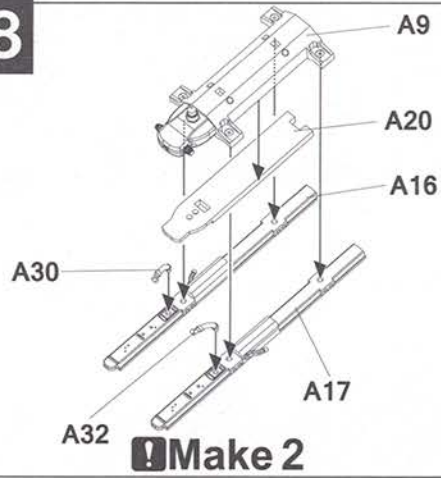

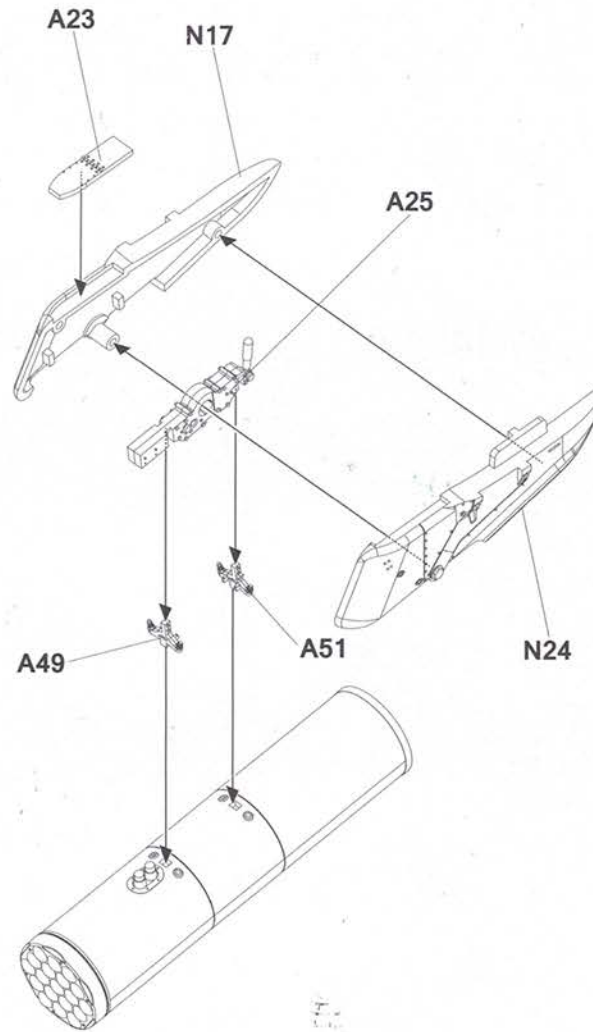
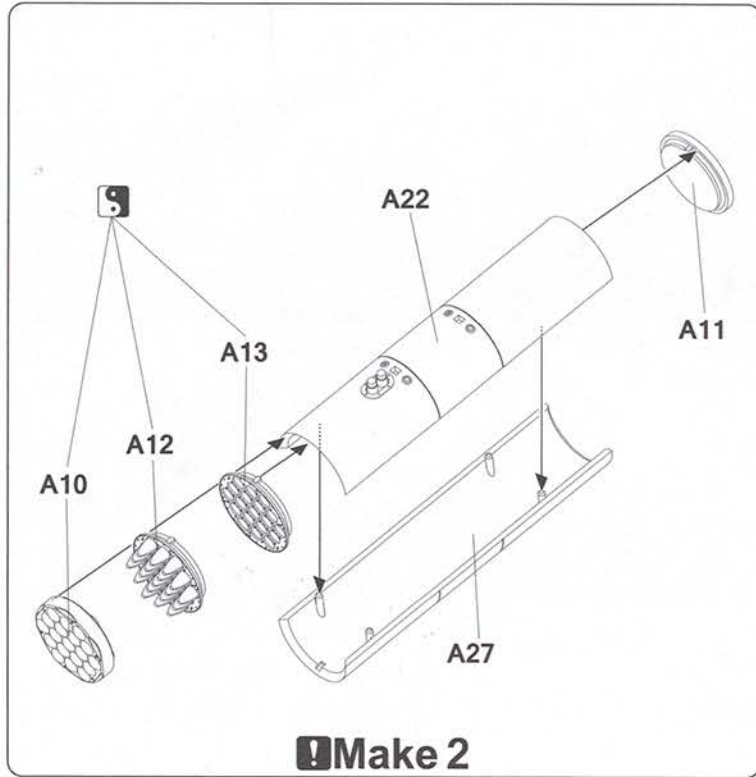

C

D

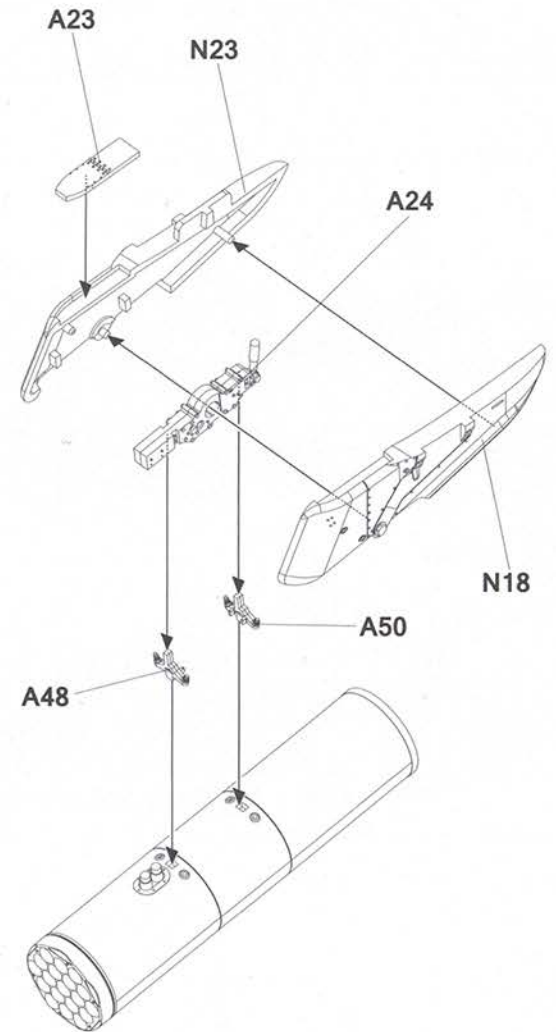

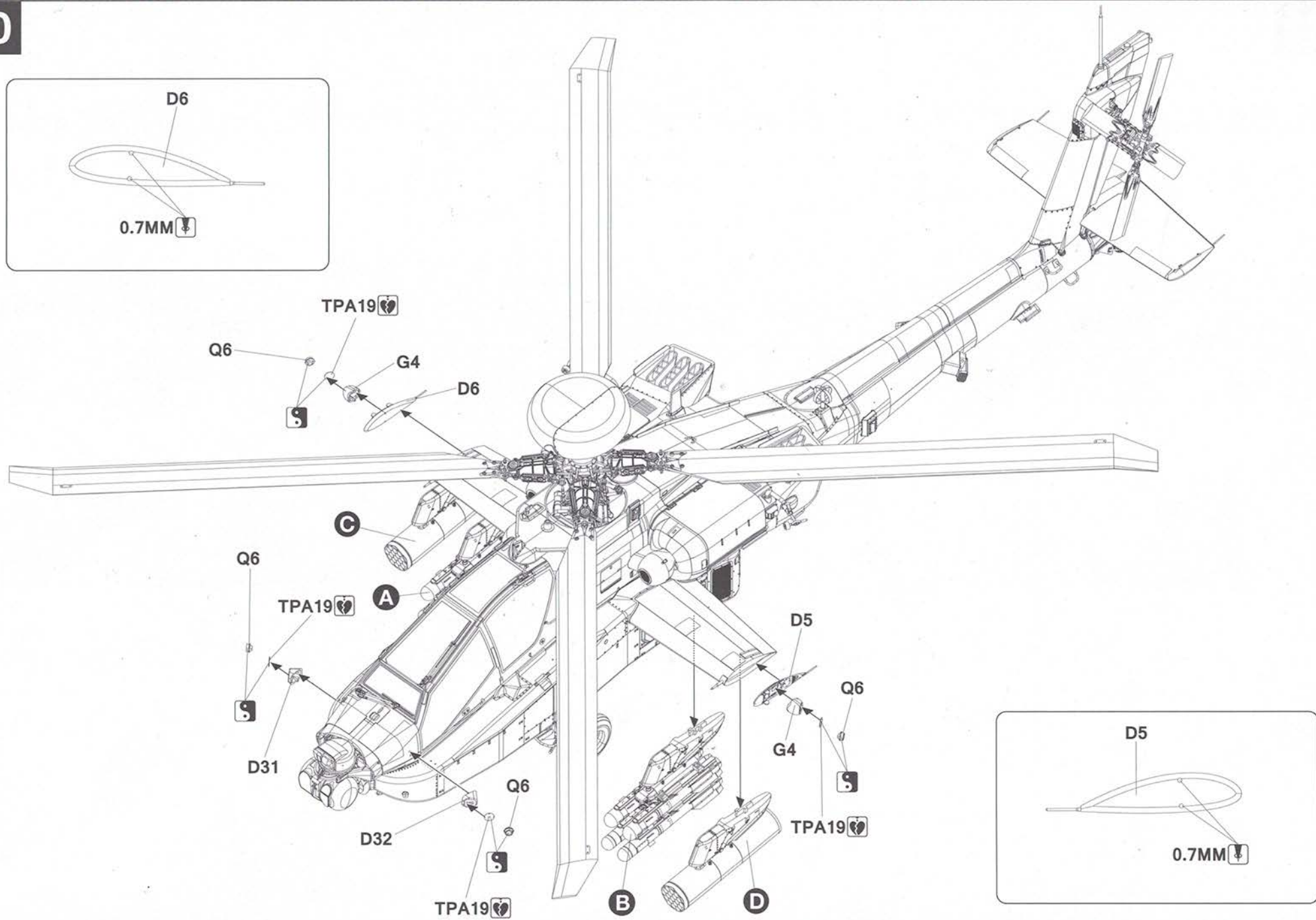

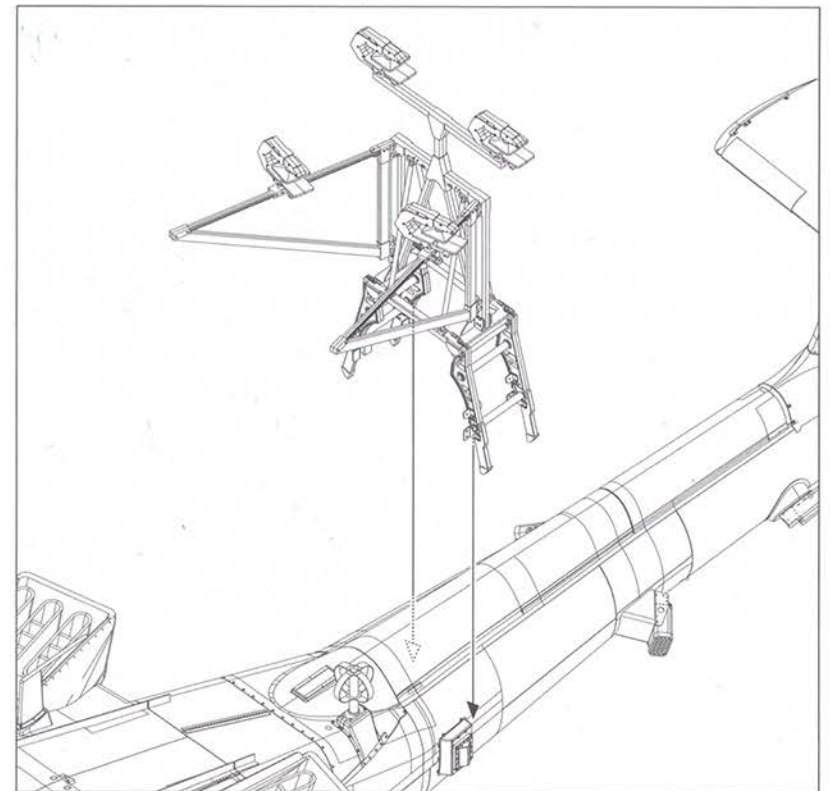
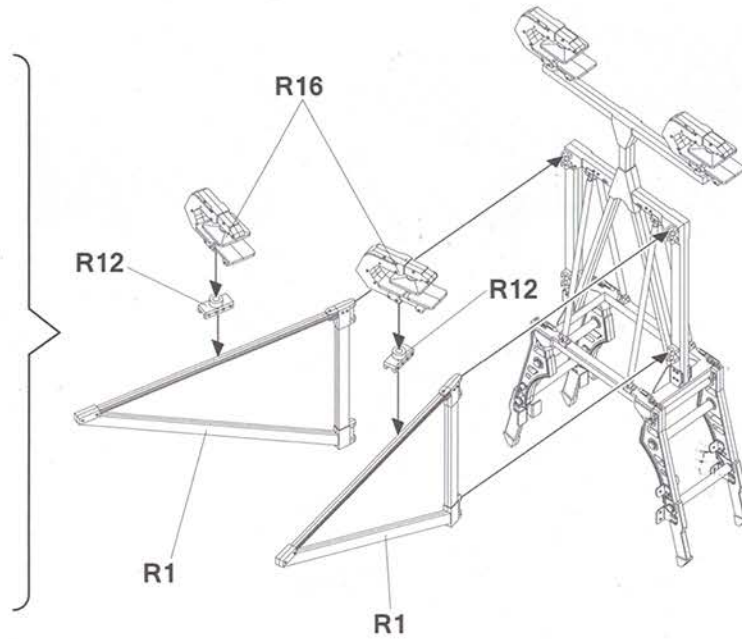
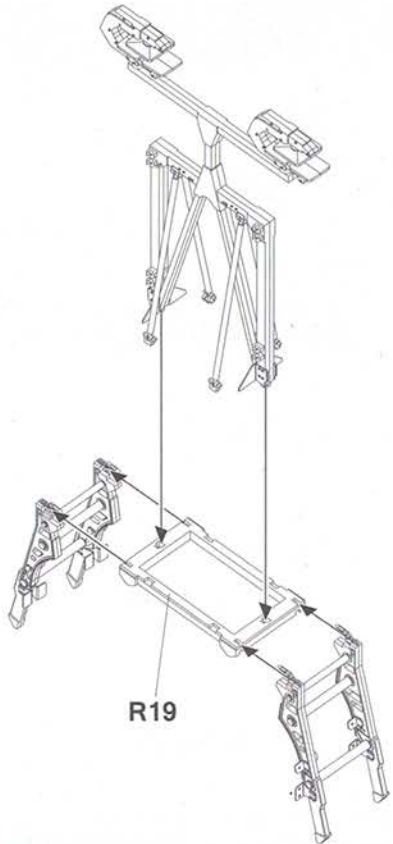
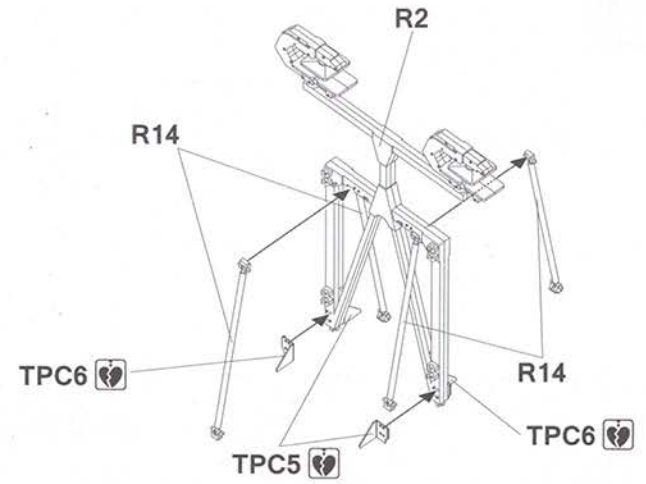
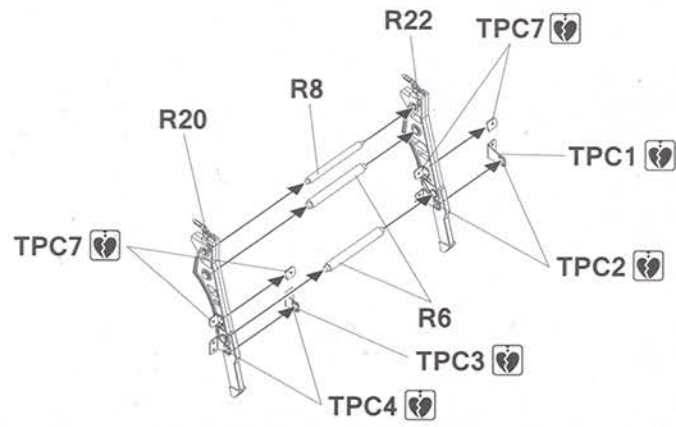
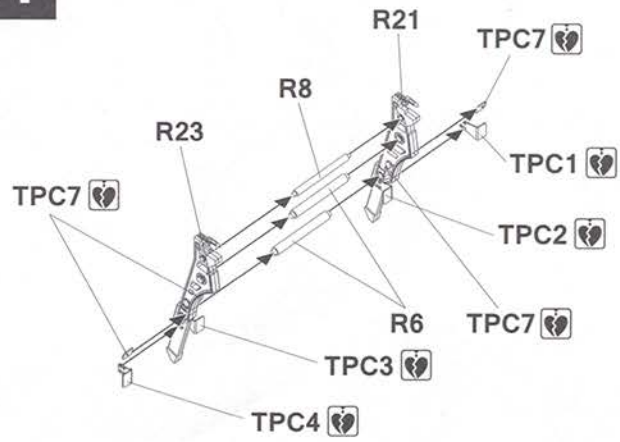

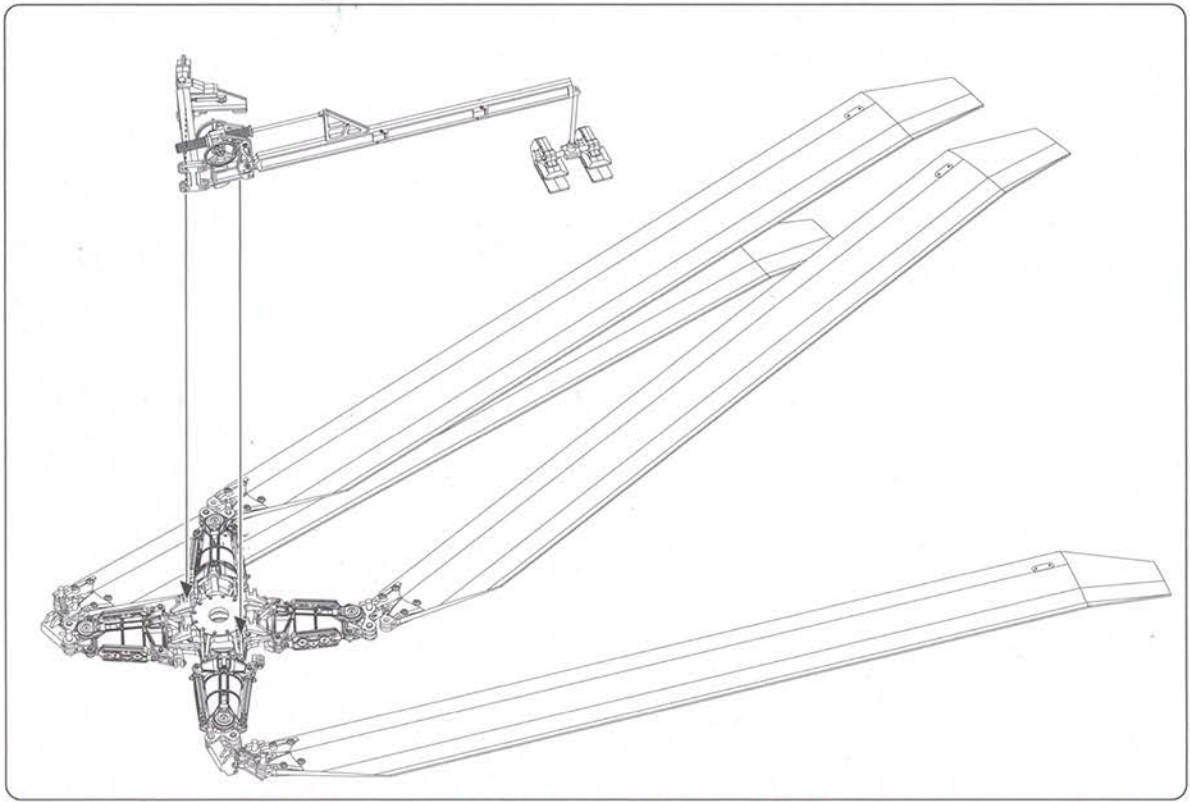
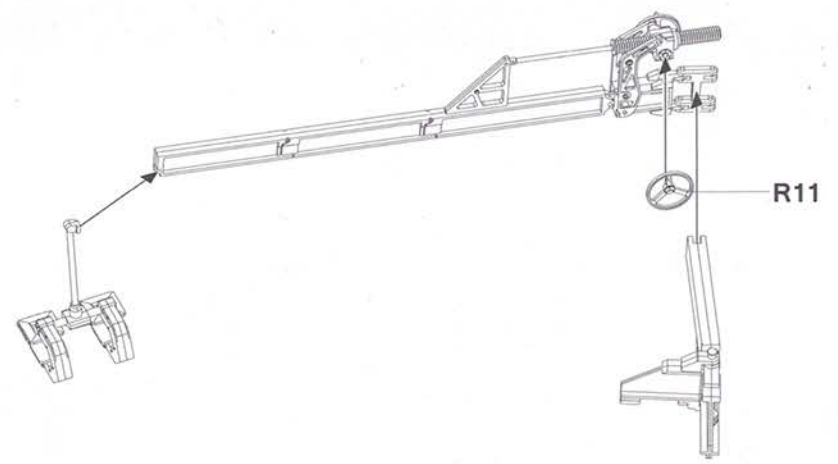
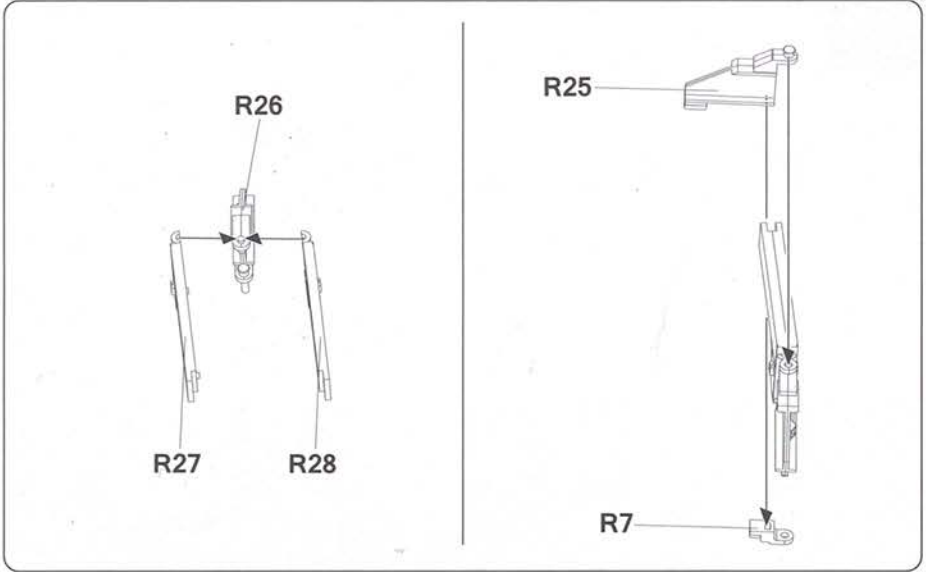
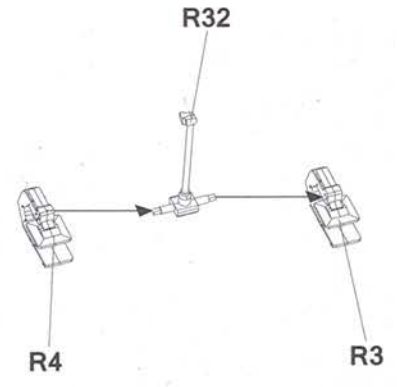
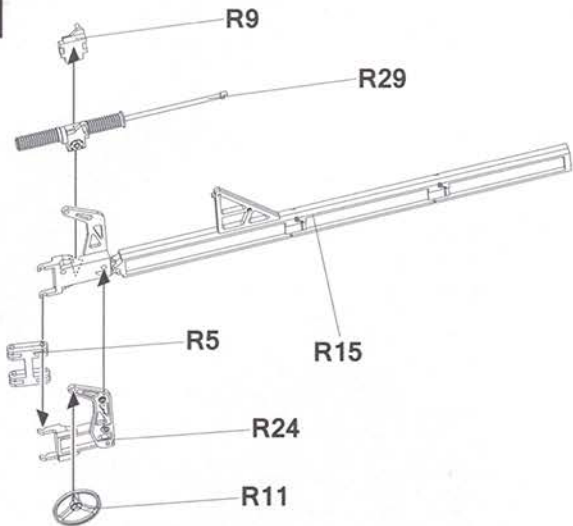

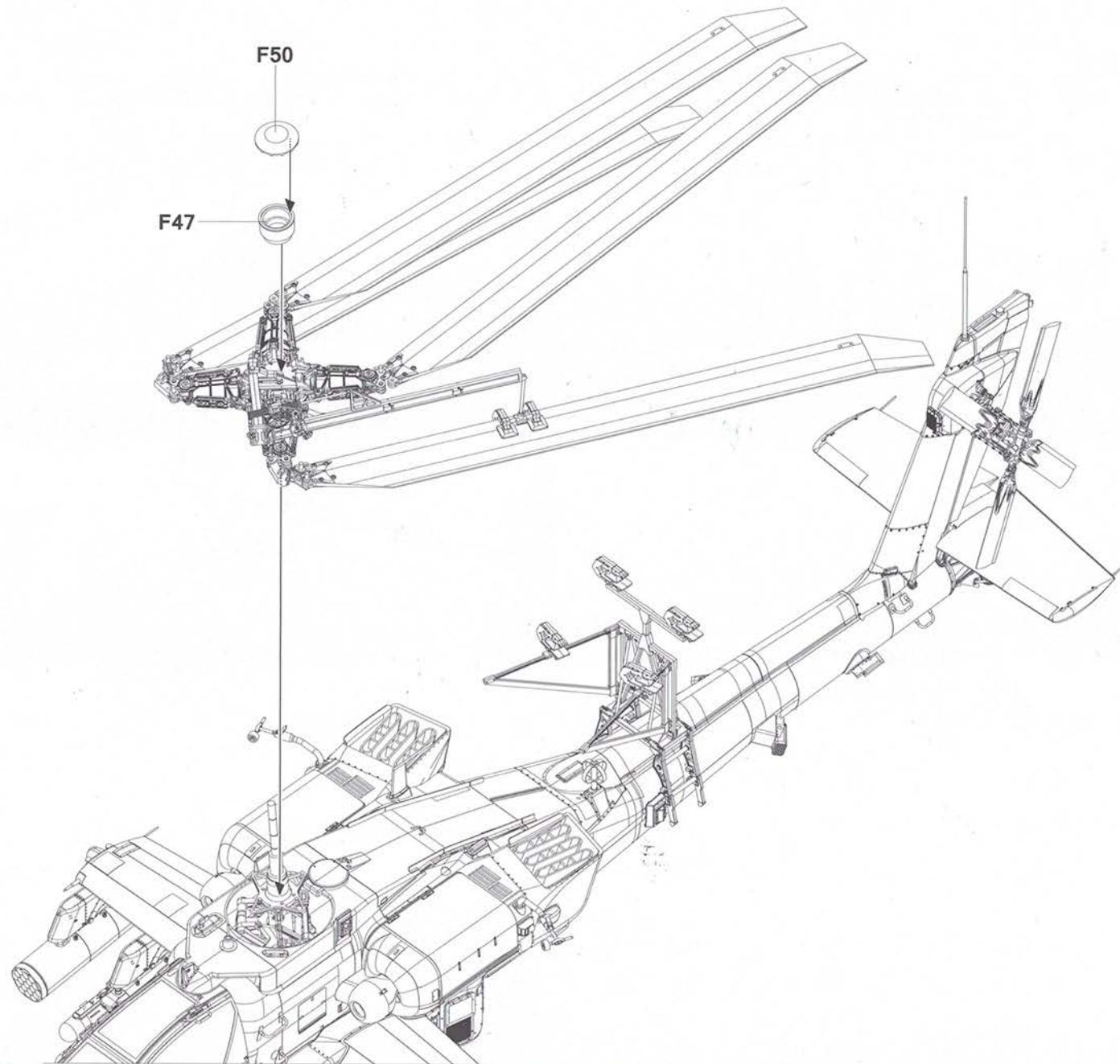



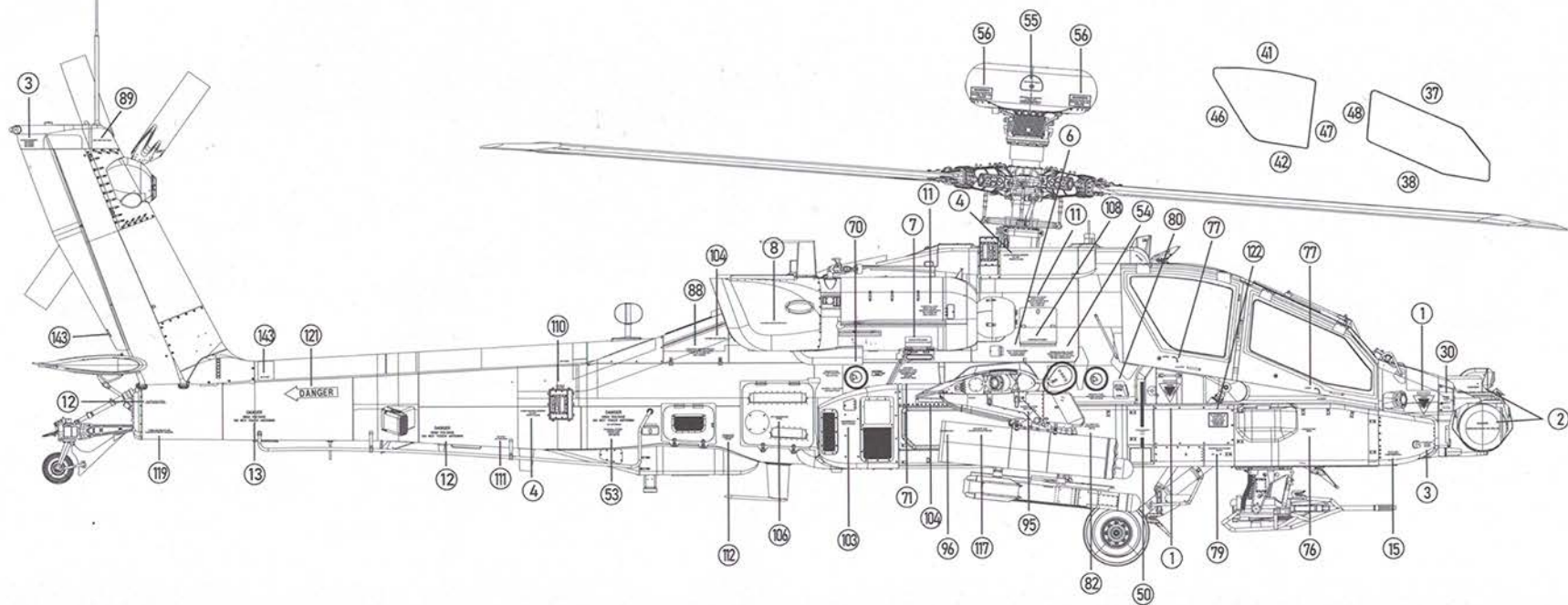
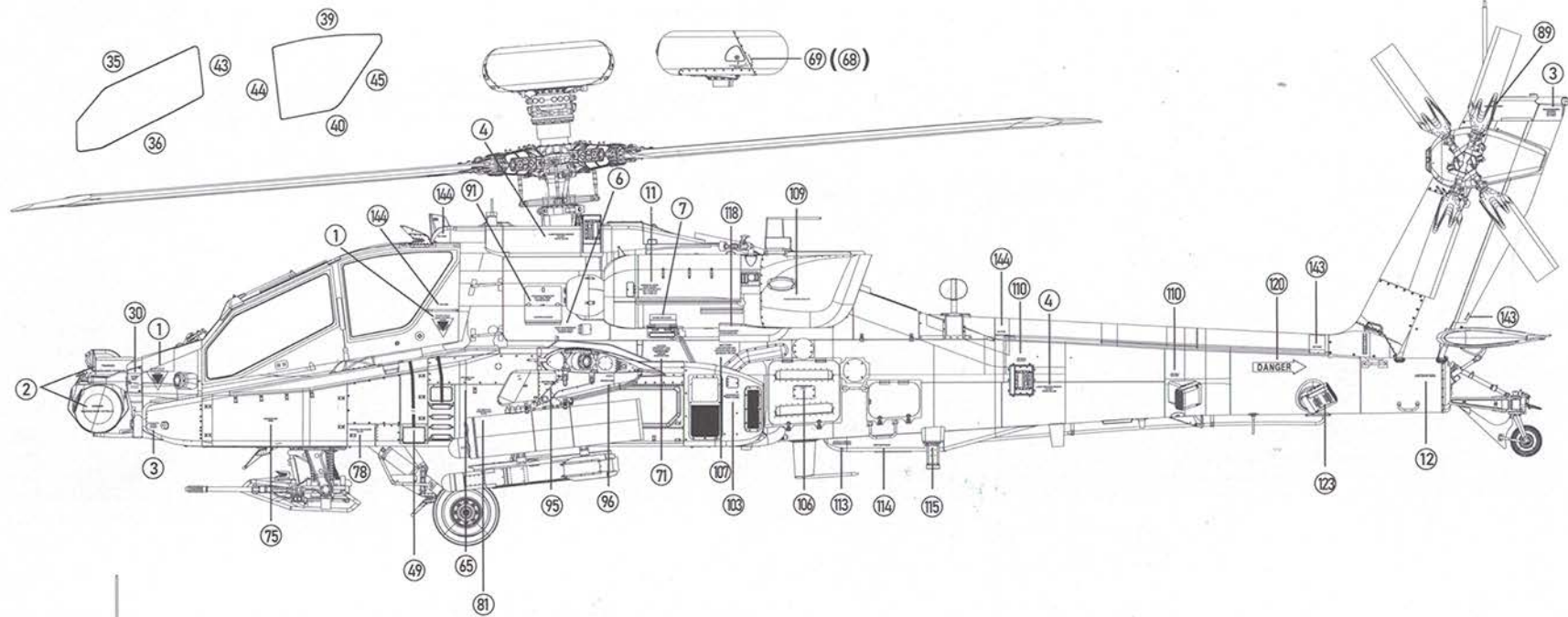

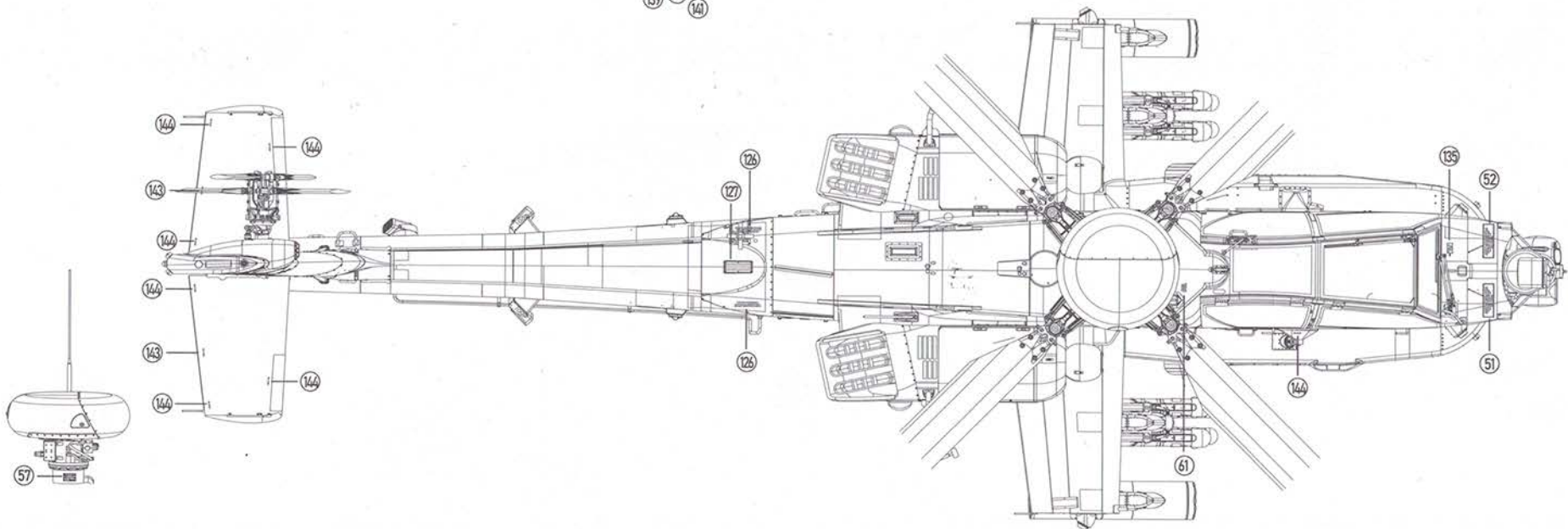
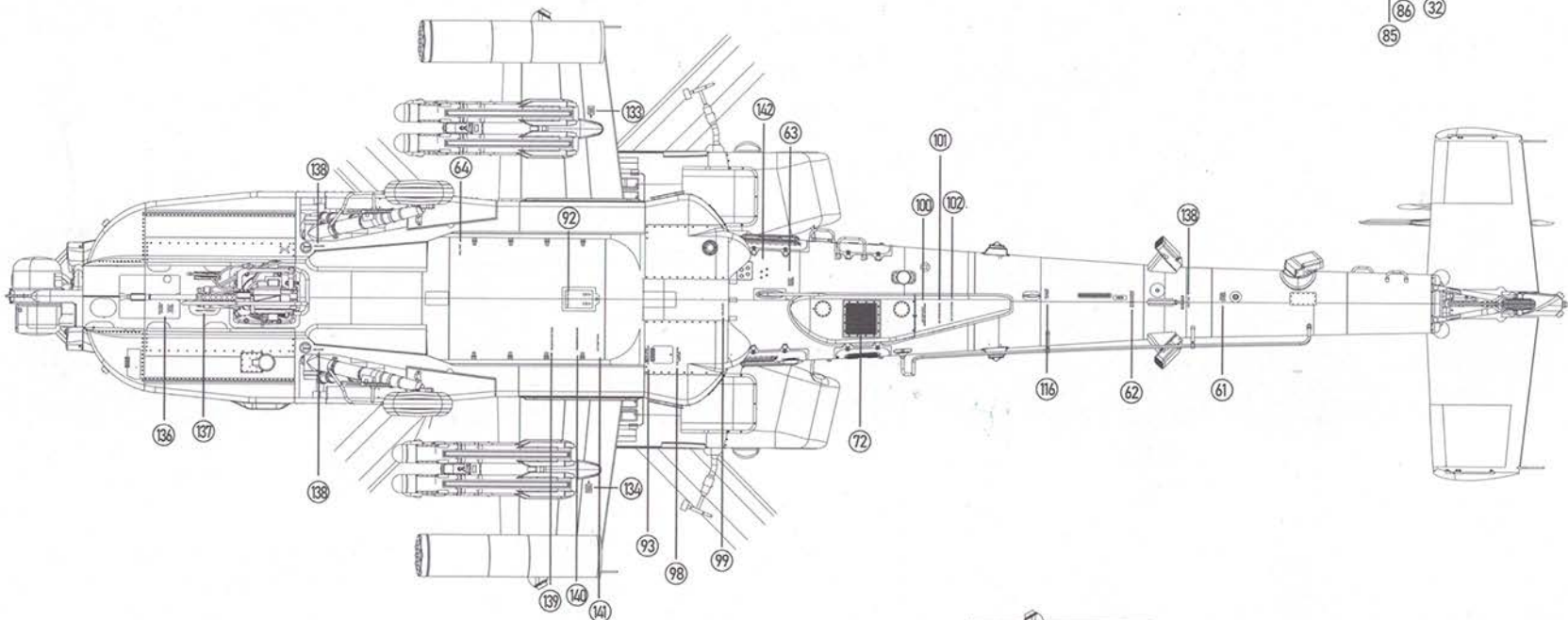
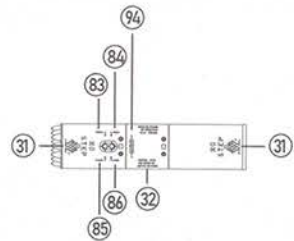
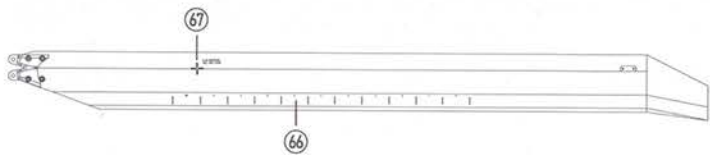

# AH-64E APACHE GUARDIAN

www.migjimenez.com



## Painting and Marking Guide

A.MIG-0925 Olive Drab Dark A.MIG-0278 Matte Black A.MIG-033 Rubber & Tire

A.MIG-0045 Gun Metal



# AH-64D APACHE LONGBOW

ATTACK HELICOPTER



# 'E' OF THE WORLD AH-64E

ATTACK HELICOPTER

LIMITED EDITION



