

WWII U.S. NAVY Douglas TBD-1 ‘DEVASTATOR’ MIDWAY 1942



二战美国海军 道格拉斯TBD-1 “蹂躏者”型鱼雷攻击机 中途岛海战

Great Planes
Hobby

ITEM L4807

Douglas TBD Devastator

On Oct 5, 1937, the first two aircraft entered VT-3 Squadron on CV-3 Saratoga and started its service.

On Dec 7, 1941, after the IJN combined fleet sneak-attack on the US Navy pacific fleet anchored at Pearl Harbor, the US entered the war. The TBD-1 got off its shining silvery coat and marched to the battle field with grey camouflage painting. It took part in almost all the US Navy actions against the Japanese fleets and harbors before the Midway campaign.

The Midway campaign was the turning point of the Pacific War and it was the last battle that TBD-1 acted as the main torpedo bomber in front-line units. The war promoted rapid progress of aviation technology and weapons, the TBD-1 became too lumpish and antiquated though it marked a large number of "firsts" when it came

1937年10月5日, TBD-1进入美国海军CV-3“萨拉托加”号航空母舰搭载的VT-3中队正式服役。

1941年, 日本联合舰队偷袭了太平洋美国海军的基地珍珠港, 美国与日本在太平洋的全面战争爆发, TBD-1脱下华丽的银色外套换上灰色的战袍开赴战场, 参加了中途岛海战之前所有的美国海军航空兵对日本舰队和港口的攻击行动。

中途岛海战是太平洋战争的转折点, 也是TBD-1作为一线鱼雷攻击机参加的最后一次作战行动。战争推动了航空技术和各种武器装备的飞速发展, 当年服役时堪称多项

into service several years ago. In the Midway campaign, when TBD-1s from VT-8 led by Lieutenant Commander John C. Waldron sighted the enemy carriers, they attacked the Japanese fleet, without the fighter escort. All fifteen TBD Devastators of VT-8 were shot down by anti-aircraft guns and the much faster Japanese Mitsubishi A6M2 "Zero" fighter, not being able to inflict any damage. Ensign George H. Gay, Jr. was to be the only survivor. Because of the determined attack and heroic sacrifice of VT-8, the fighter cover of the Japanese fleet was kept occupied, while three squadrons of American SBDs began diving-bombing the IJN aircraft carriers without any disturbance. Three carriers were put out of action and were eventually abandoned and scuttled, which led to the final victory of the battle of Midway.

技术第一的TBD-1已经显得过于笨重和过时了, 中途岛海战中, 当VT-8中队在队长约翰·沃尔顿少校的带领下来到日本联合舰队的上空时, 既没有俯冲轰炸机的联合攻击也没有“野猫”战斗机的掩护, VT-8中队在日本防空火炮和轻巧的“零式”战斗机的打击下被悉数击落, 只有乔治·盖伊少尉一个人幸存下来。正是由于VT-8中队果敢的进攻和英勇的牺牲, 牵制了日本舰队的防空火力, 得以让俯冲轰炸机中队没有干扰的对日本航空母舰进行俯冲攻击, 一举击沉了日本舰队中的3艘主力航空母舰。取得了中途岛海战的胜利。

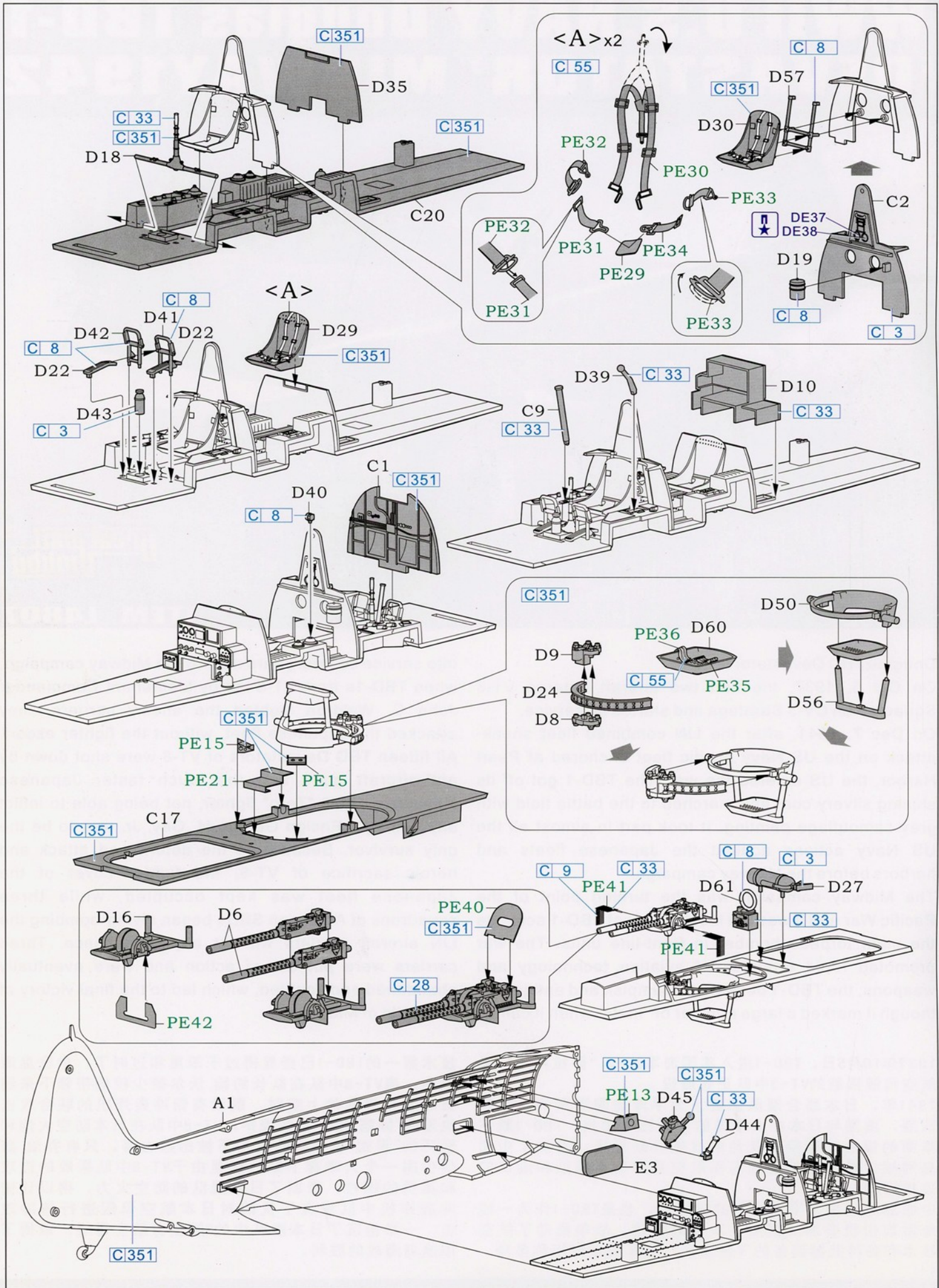

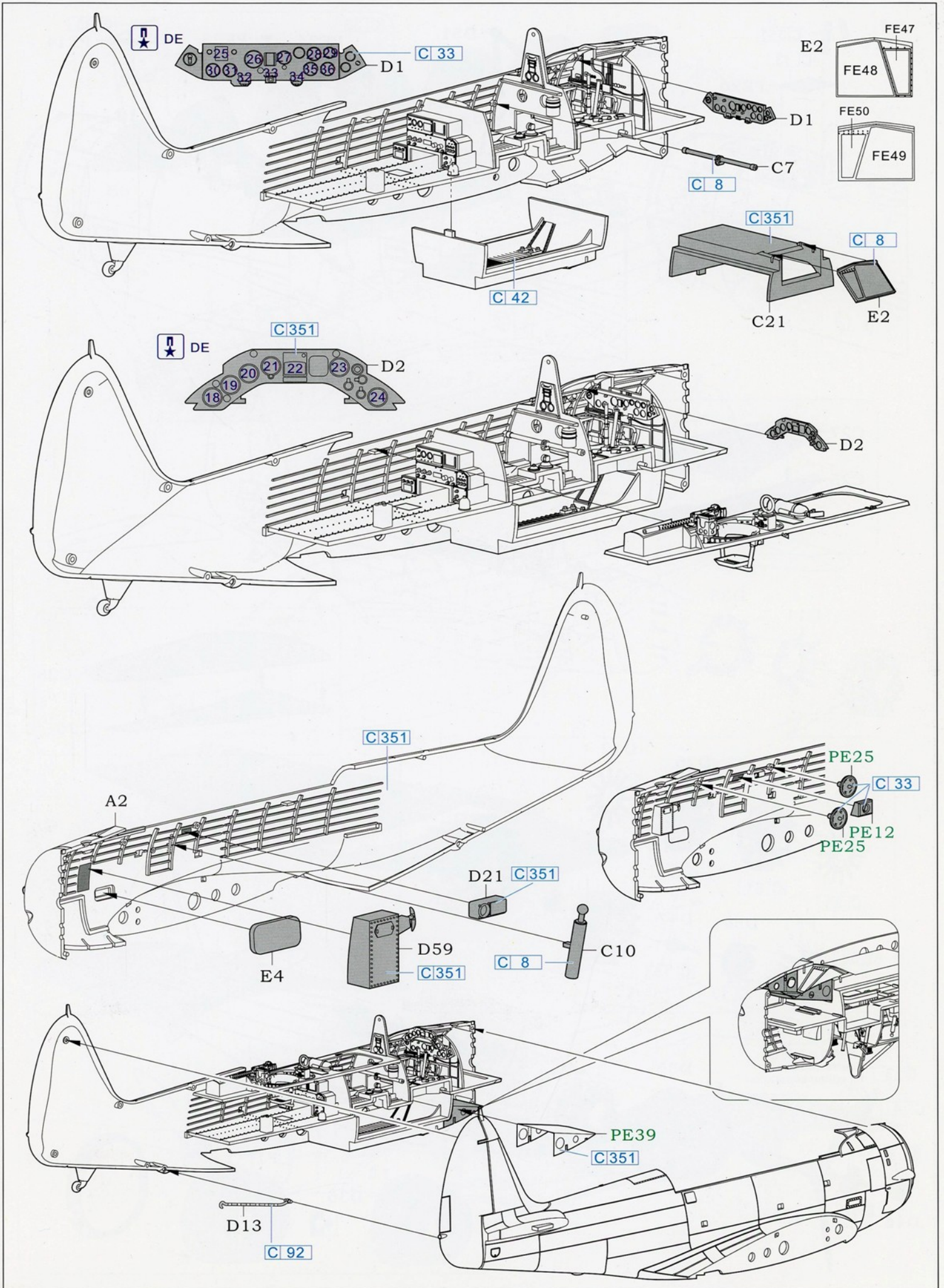

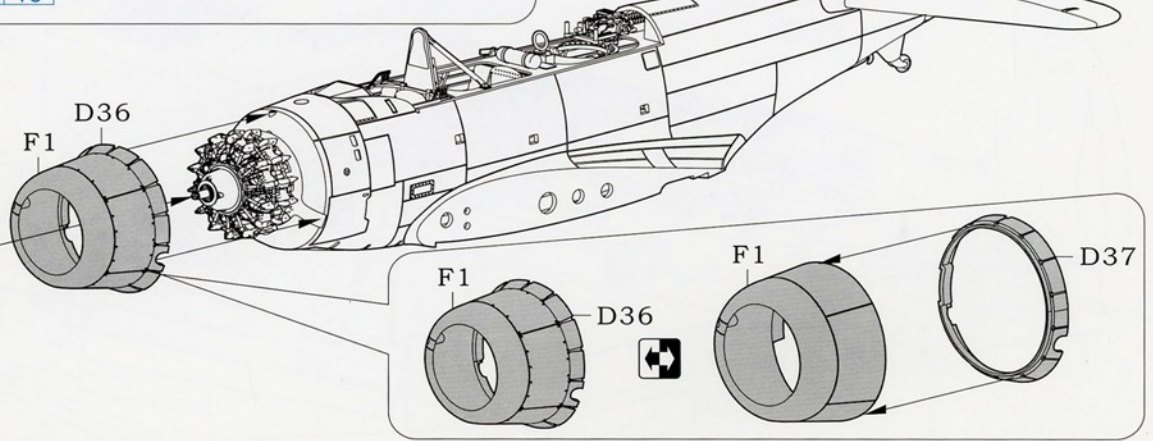
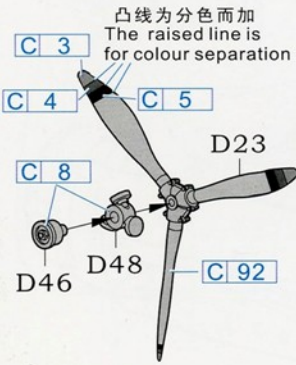
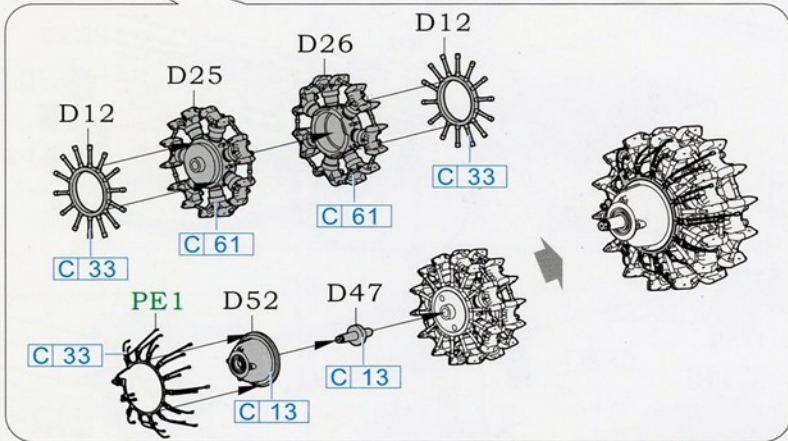
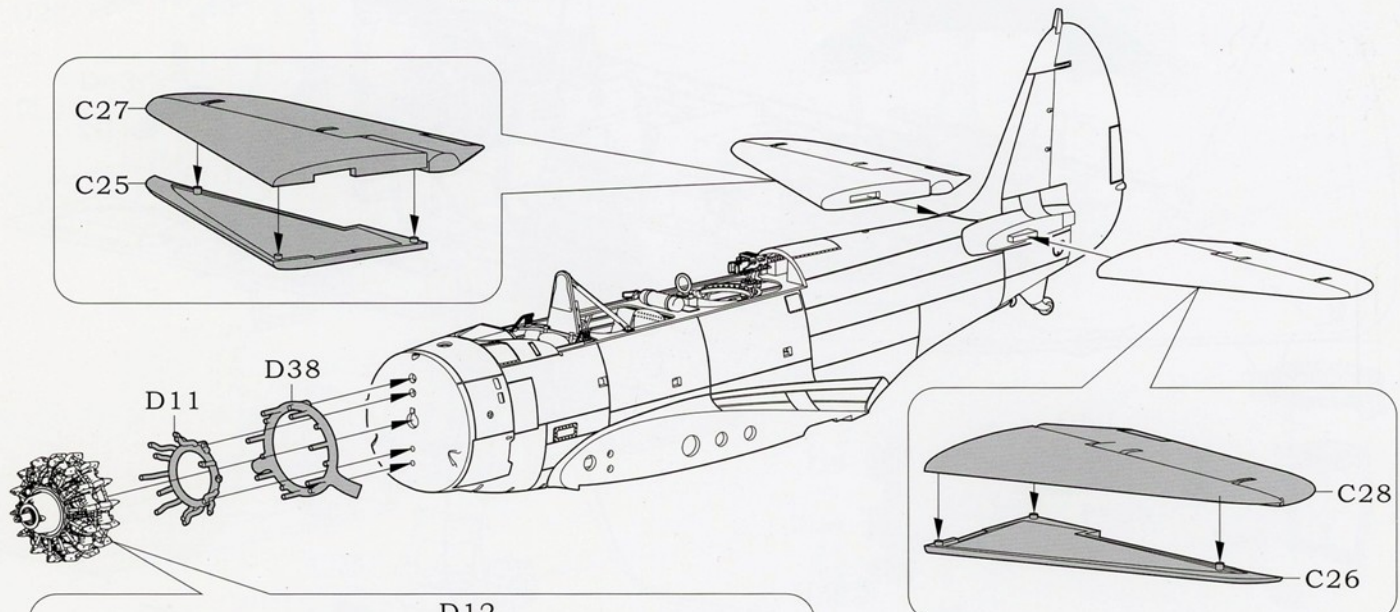
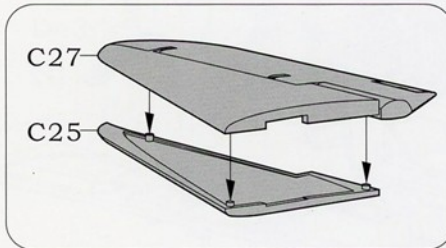
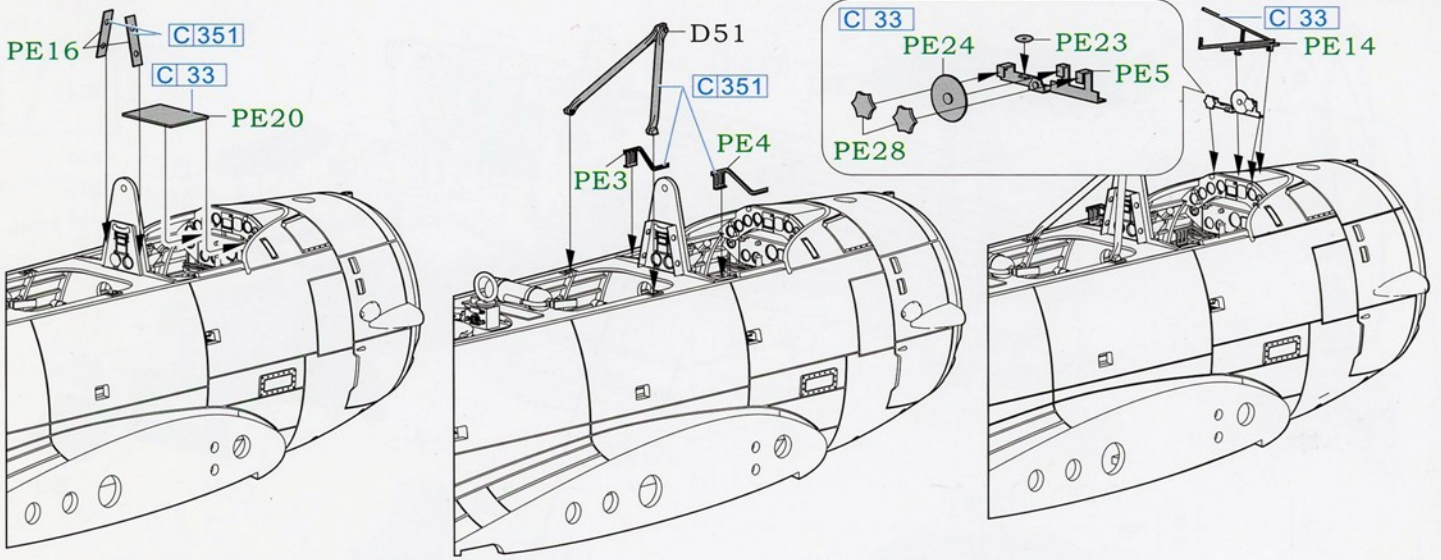

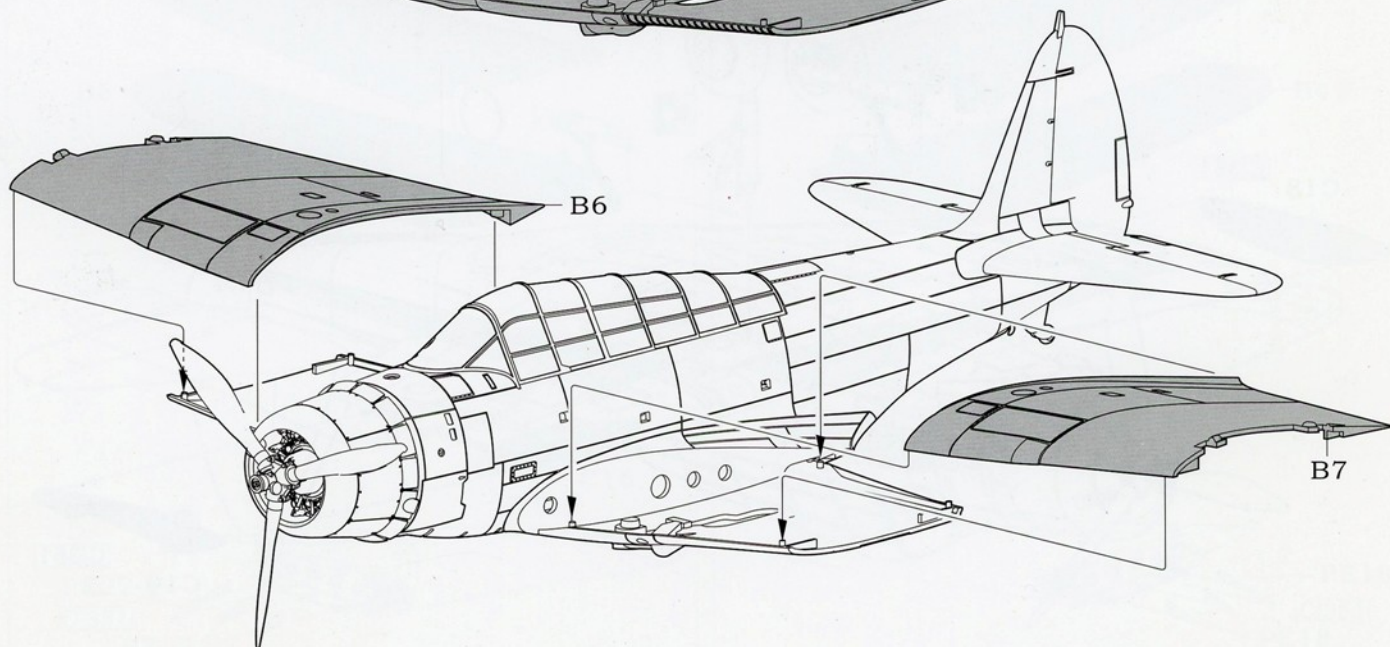
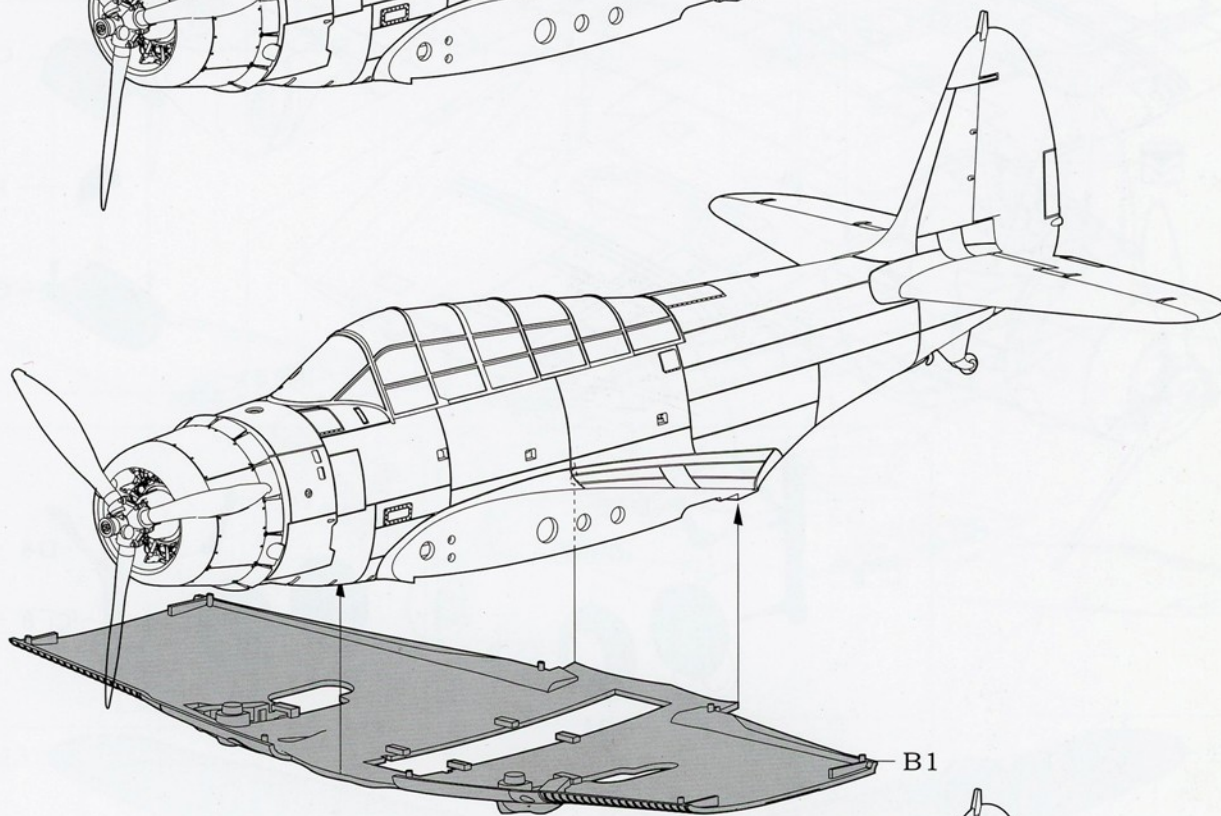
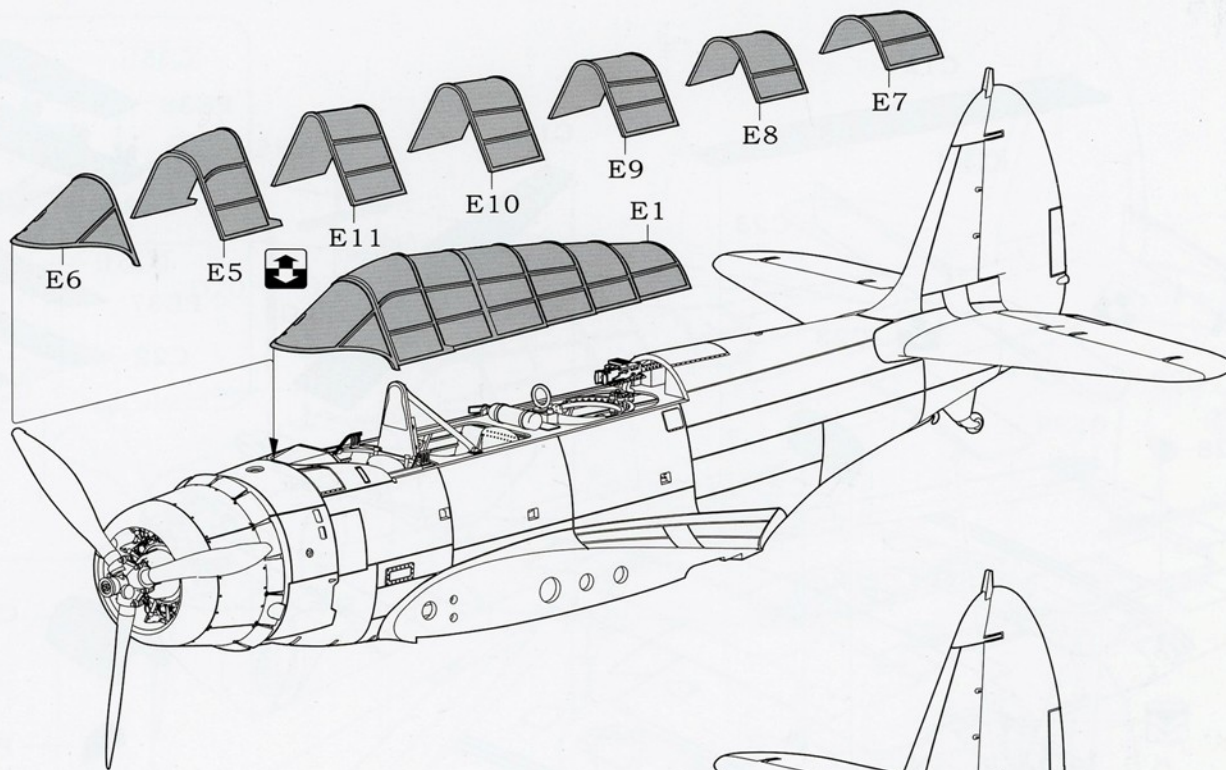

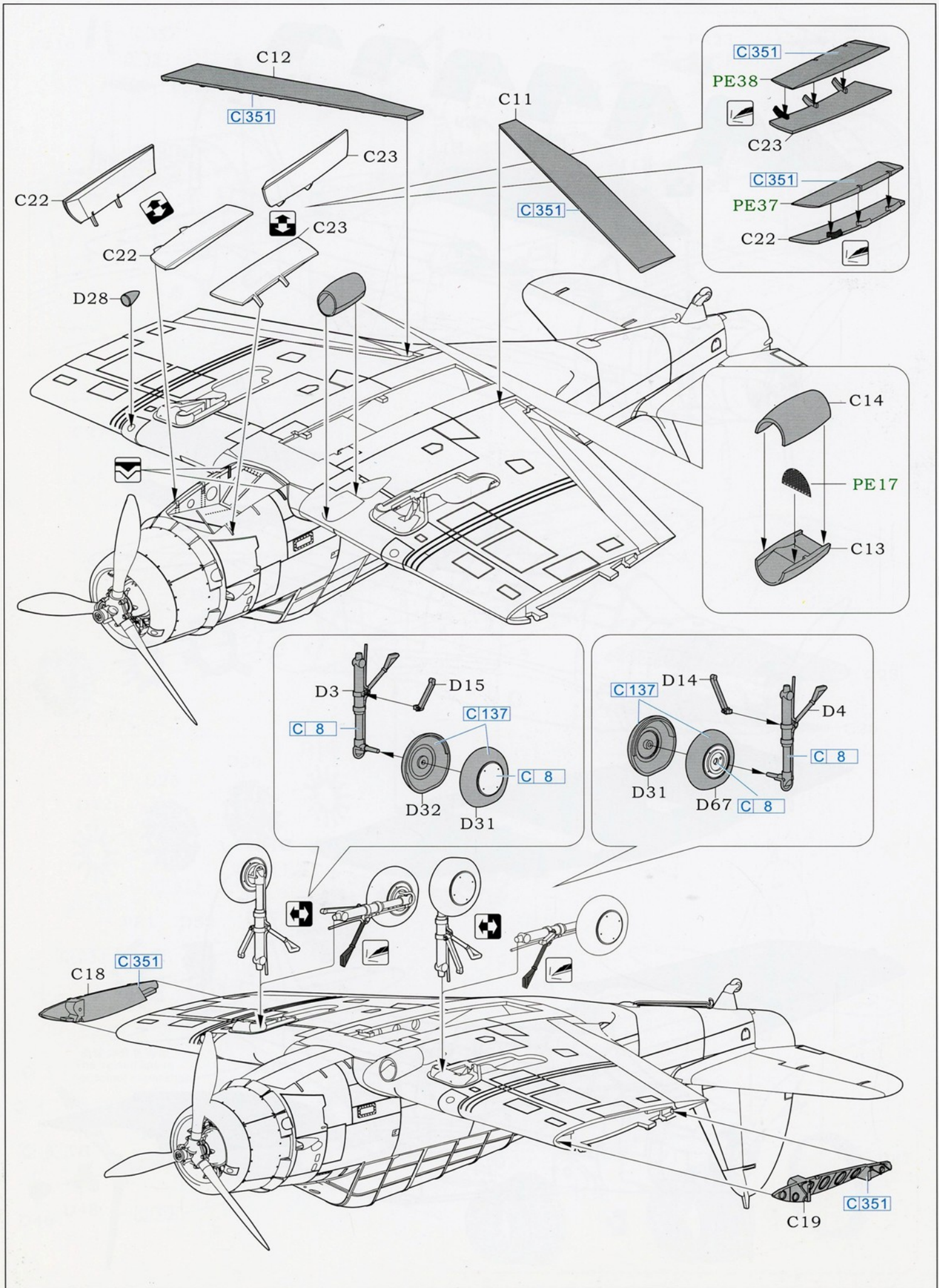

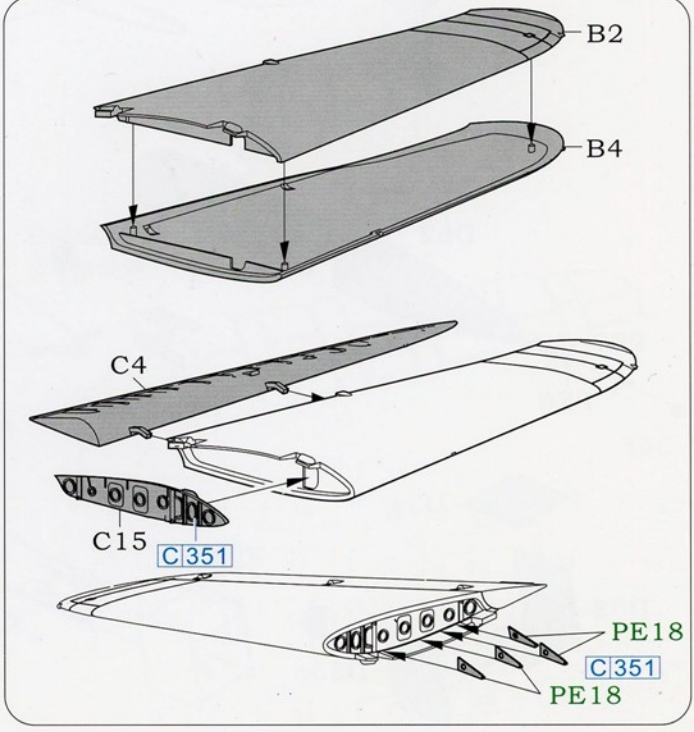
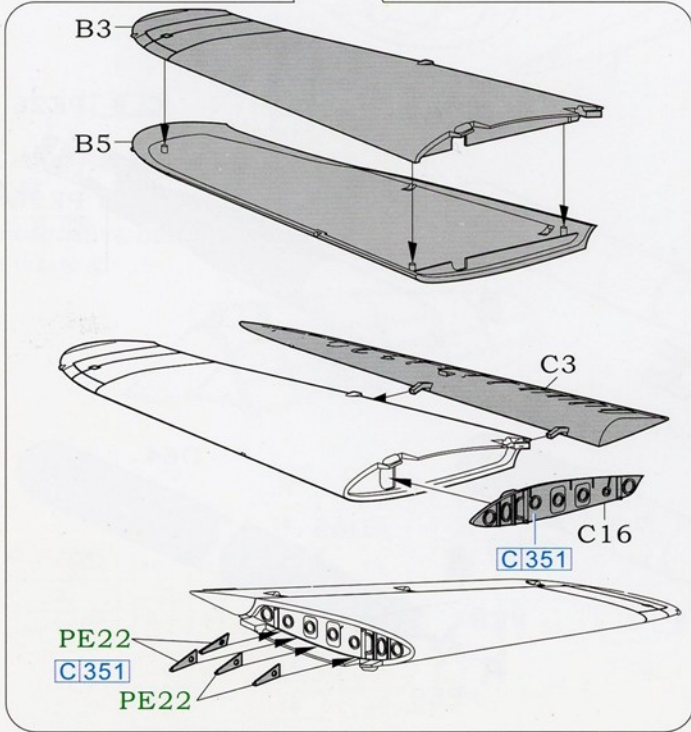
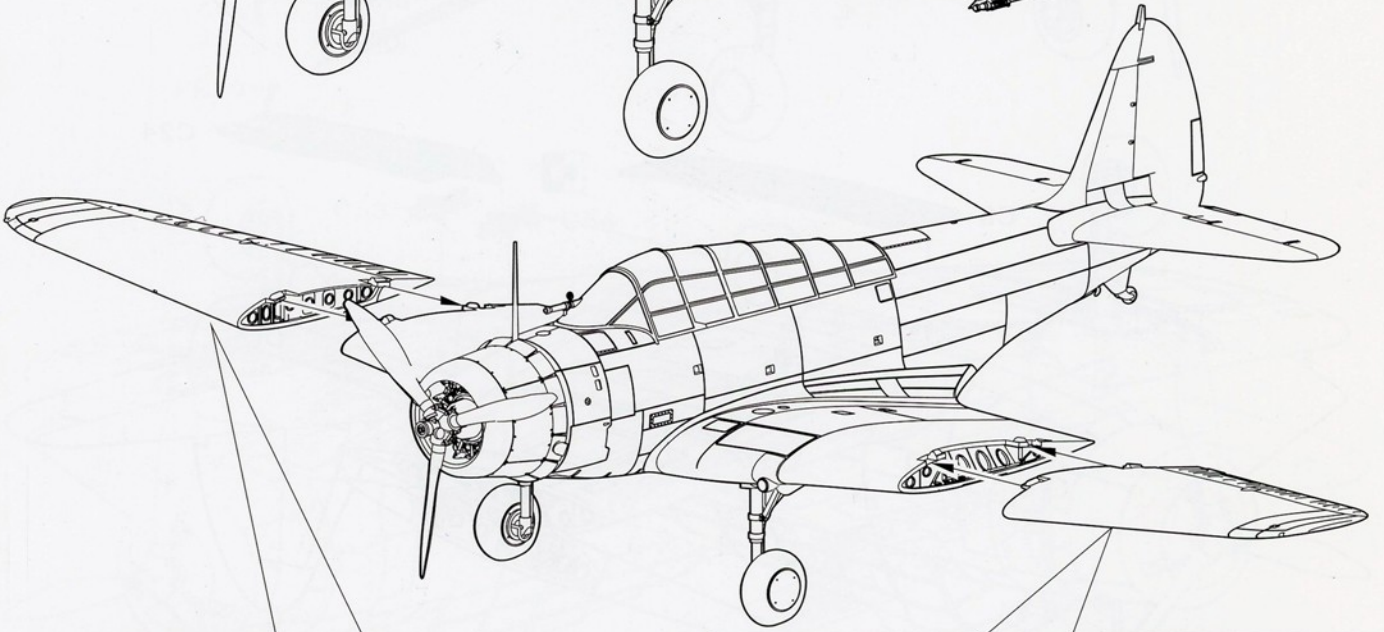
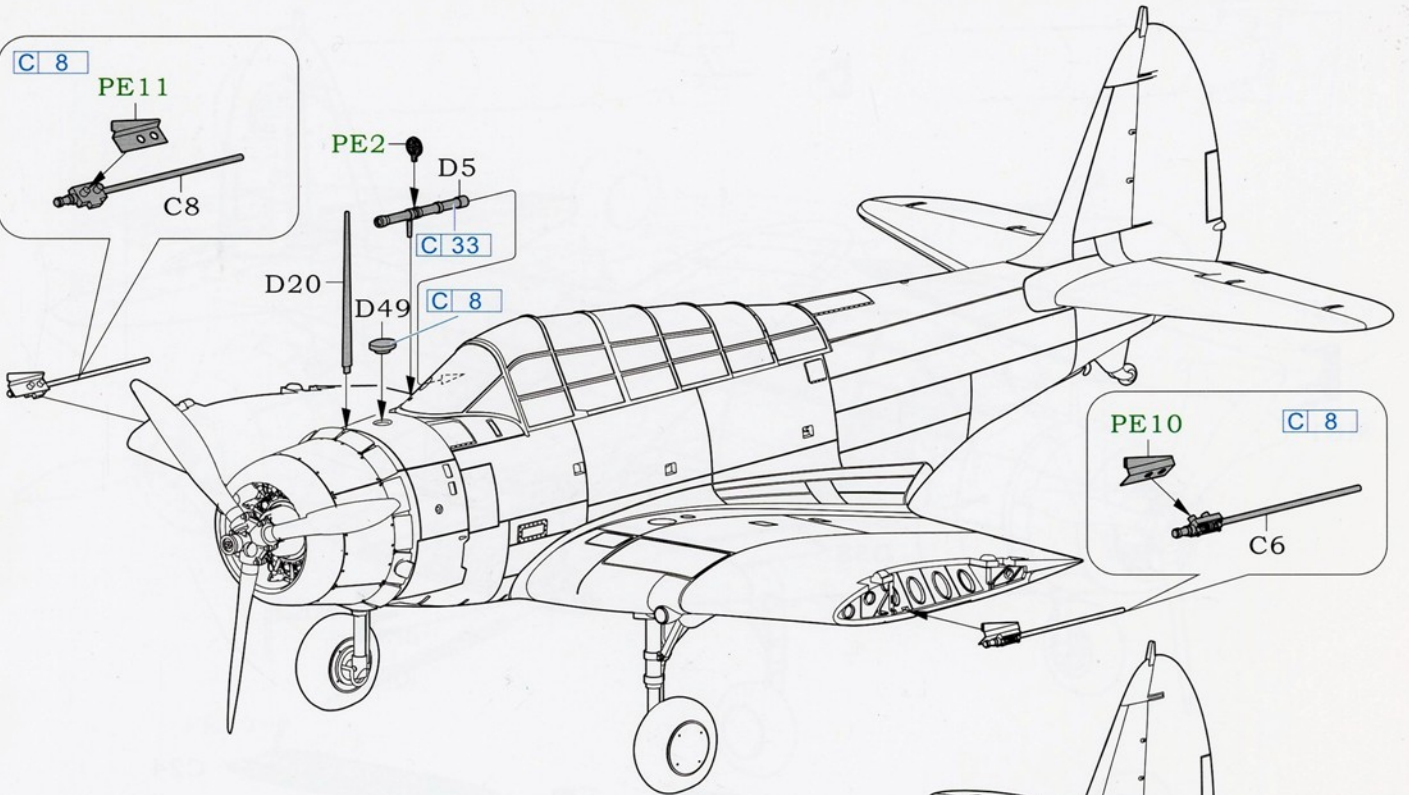
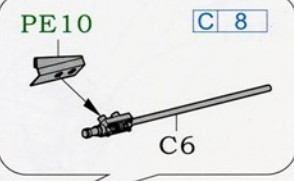
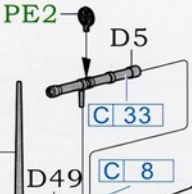
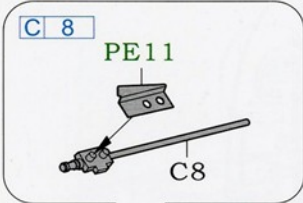

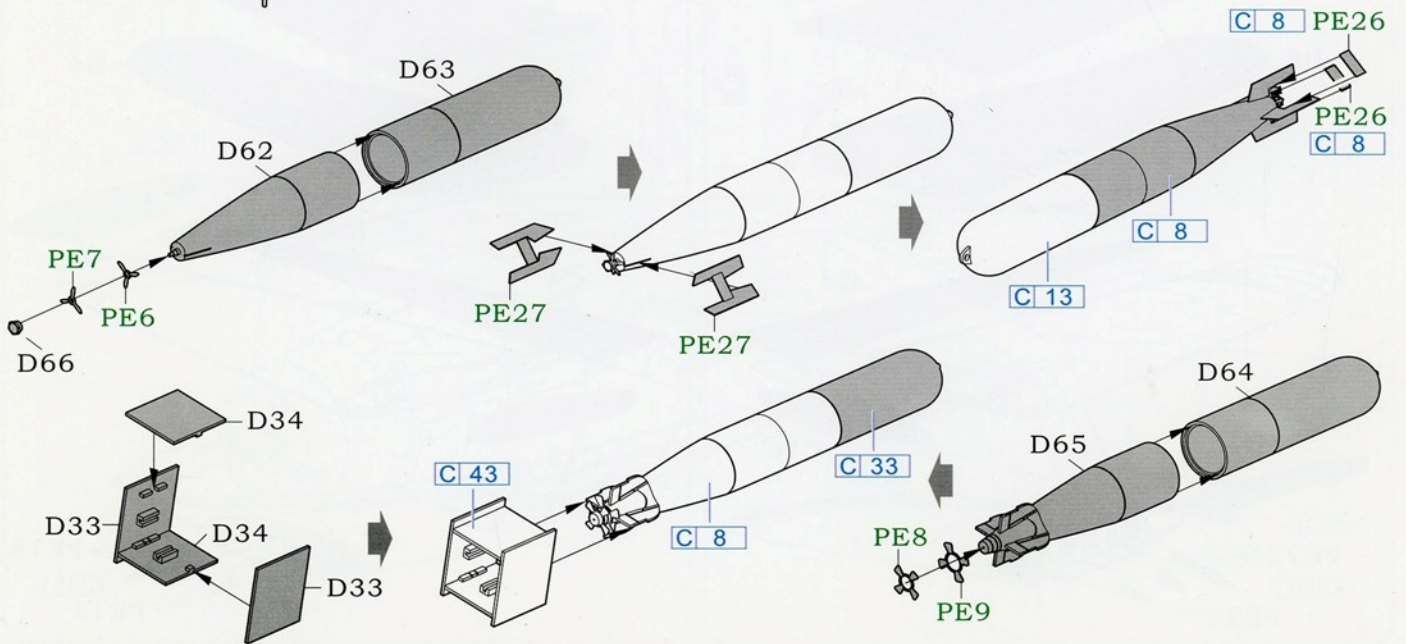
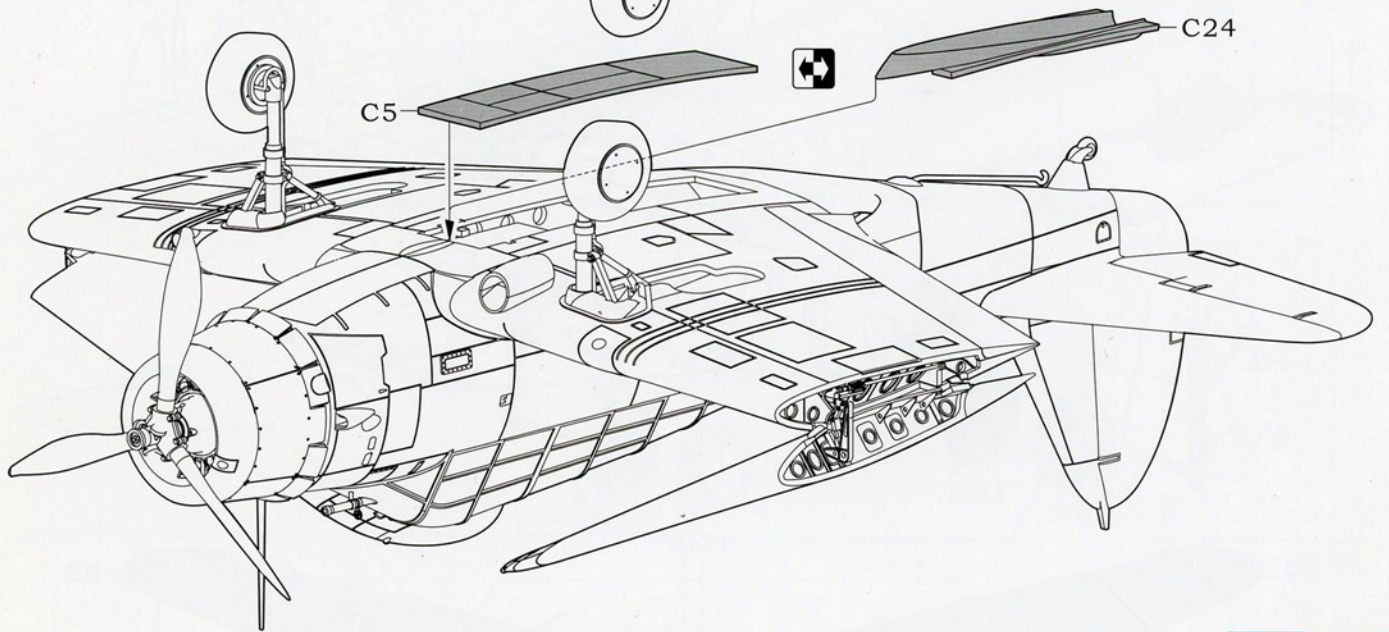
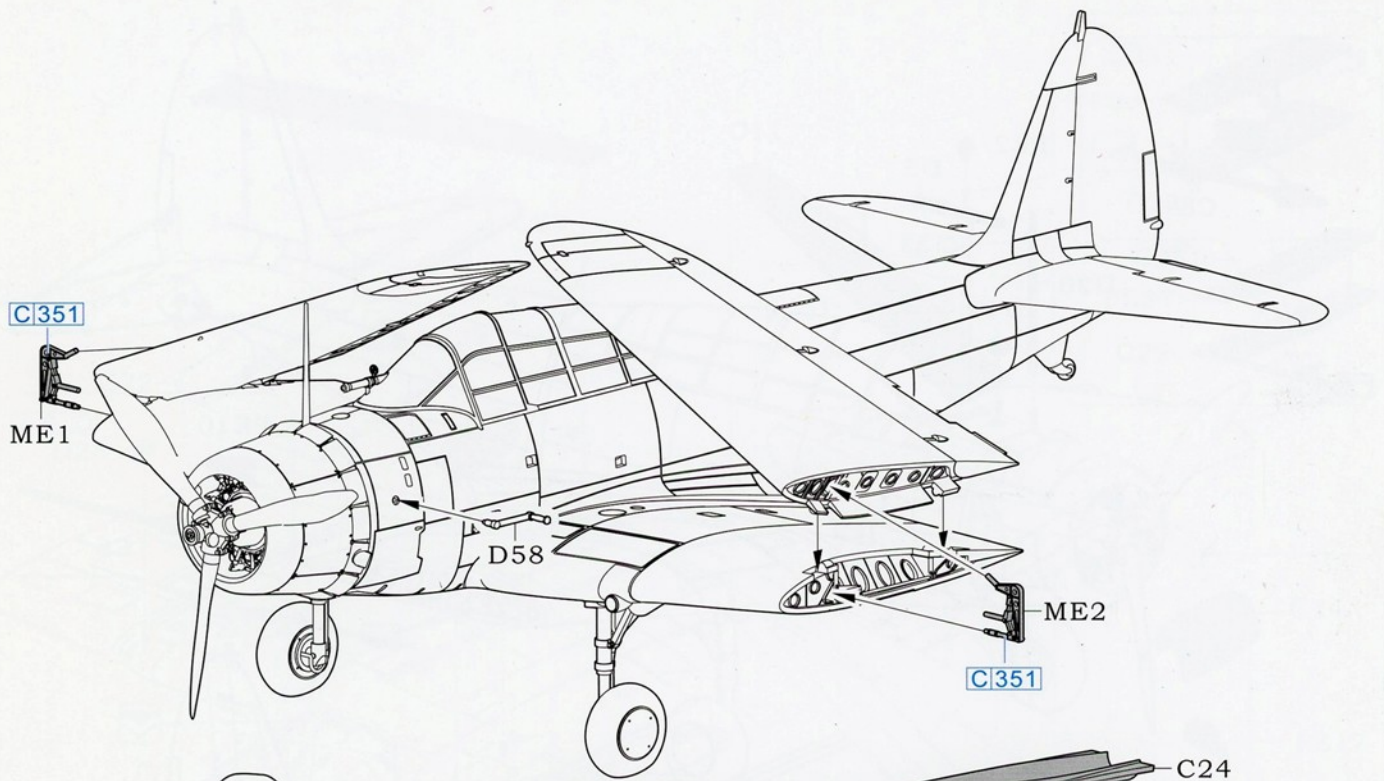

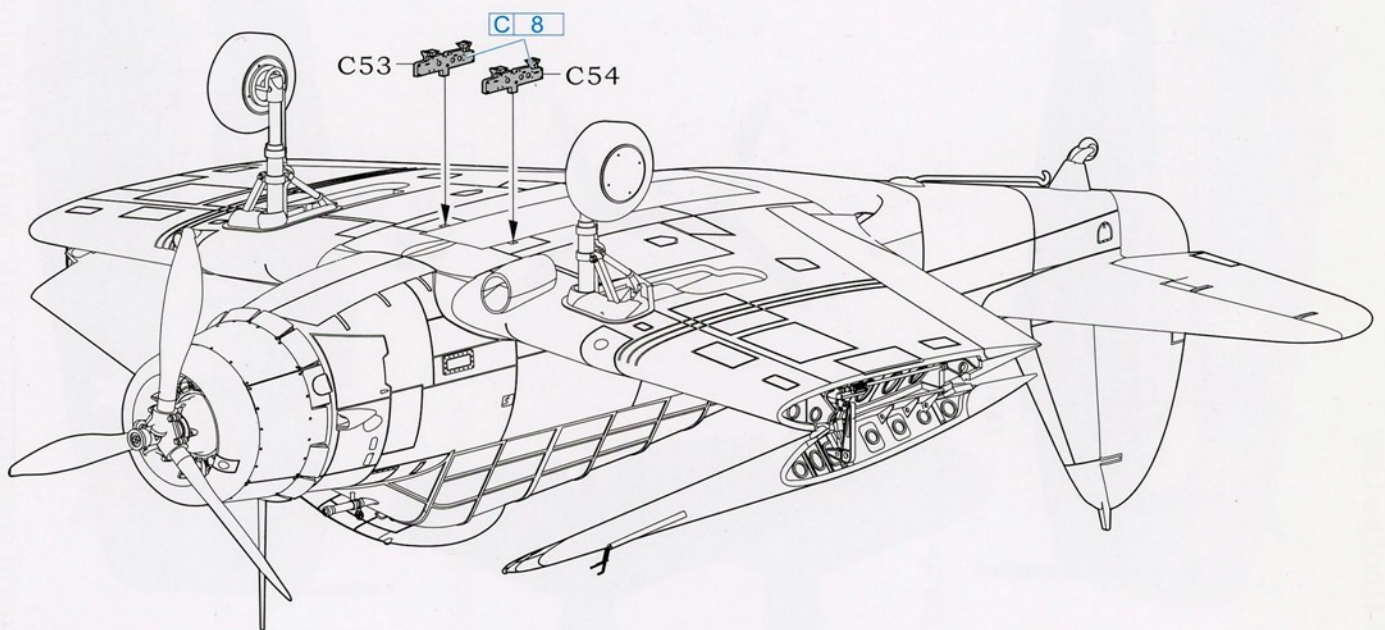
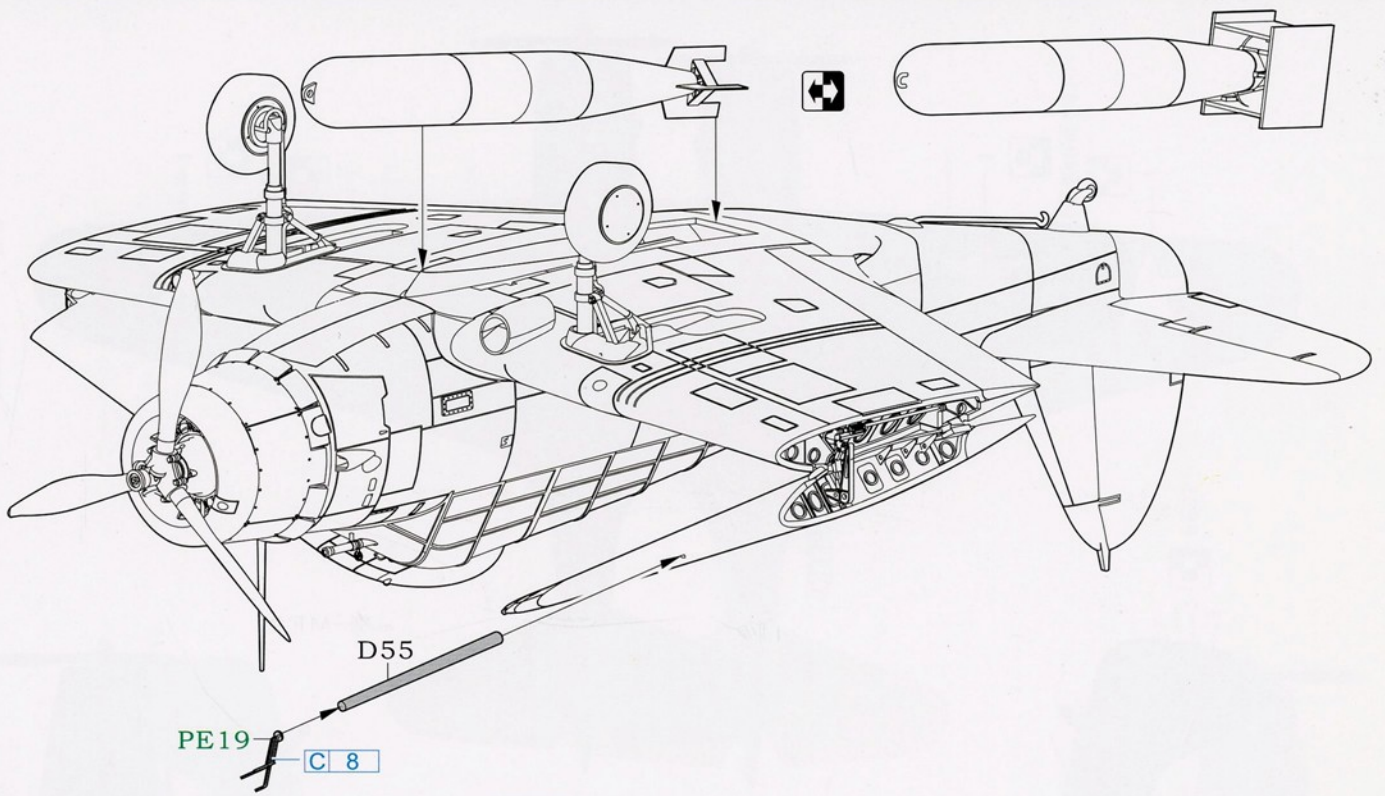

Canopy mask
窗贴

Integrative canopy mask
整体机舱盖

Detached canopy mask
分体机舱盖

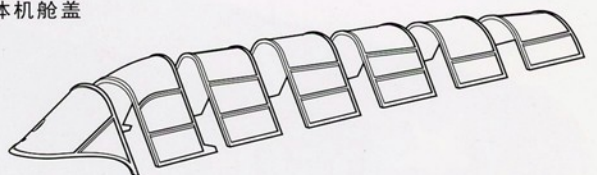
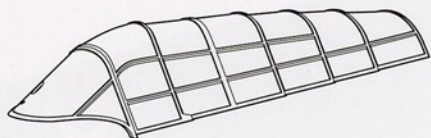

1 VT-8 aboard U.S.S HORNET ENS George Gay

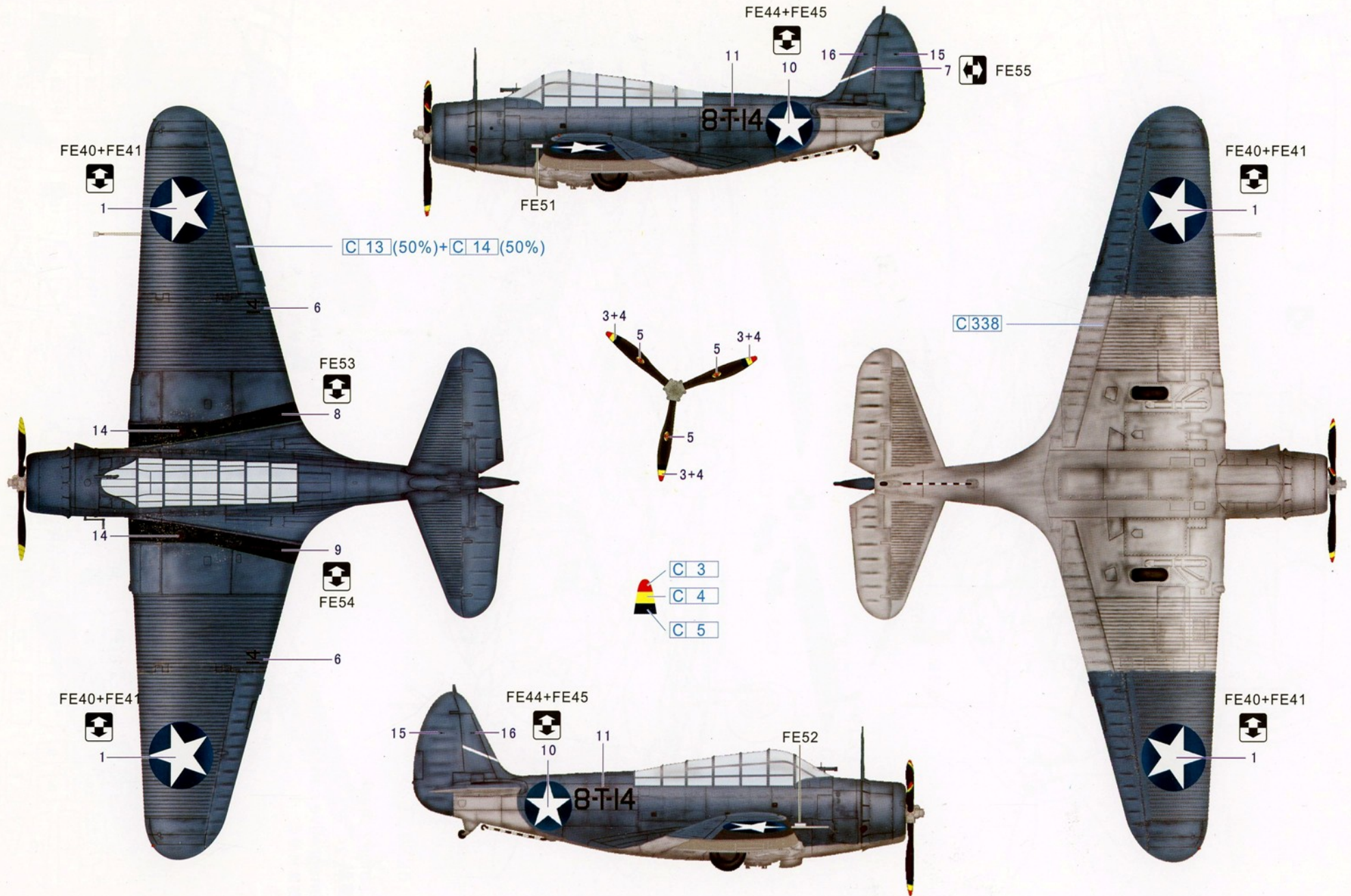

2 VT-8 aboard U.S.S HORNET squadron commander LCDR John C. Waldron

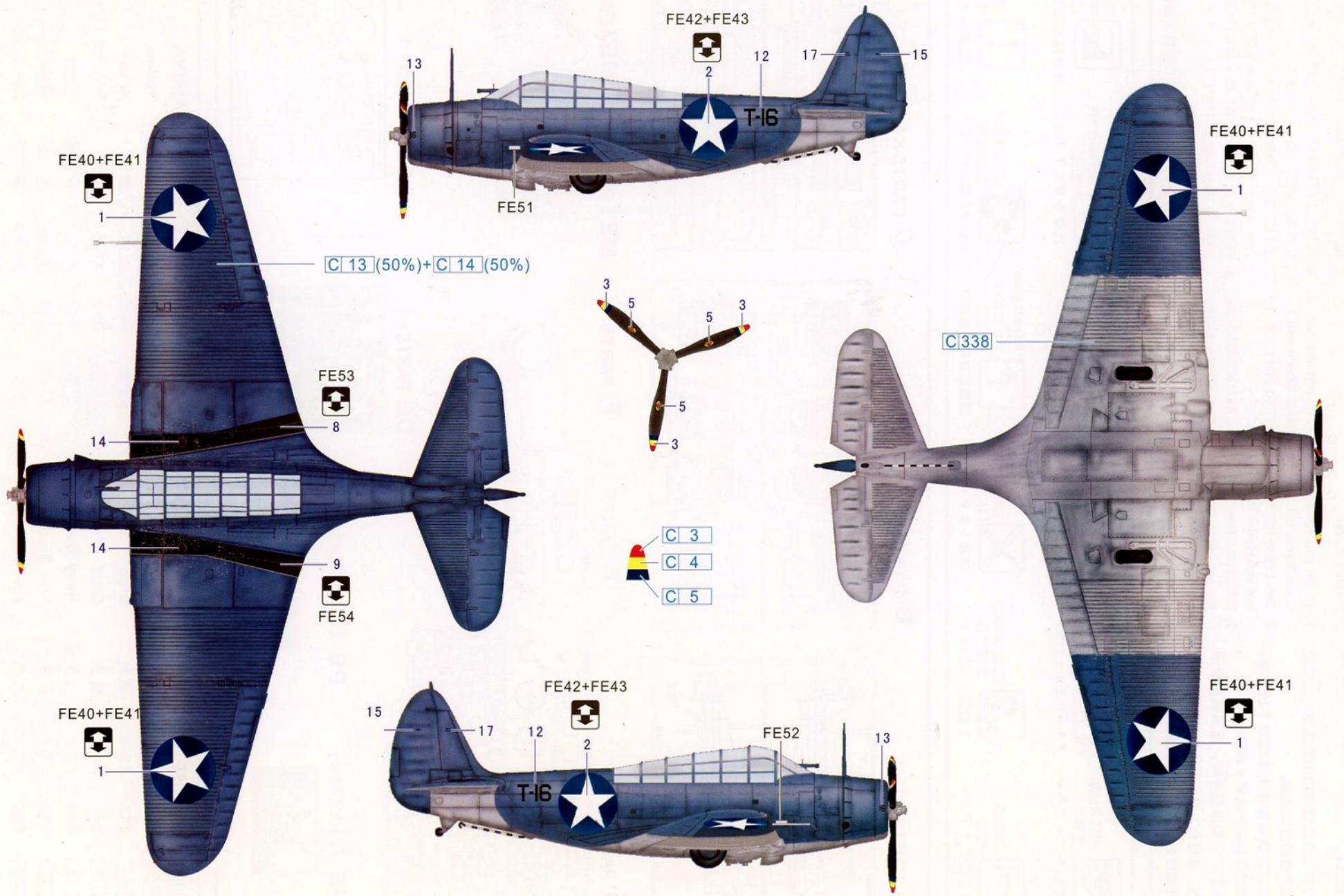

△注意:

1. 勿於近火處使用膠水或油漆，並打開窗戶保持空氣流通。
2. 塗料的號碼請參考本欄以下的說明。本品本身不包括膠水和塗料。
3. 自膠架中取出部件時，應用模型專用剪，並用介刀或小挫除去多餘膠料。
4. 各圖形的含義可參考本欄以下的說明。

△CAUTION:

1. When you use glue or paint, do not use near a open flame, and use in a well-ventilated room.
2. See below for the color list. Glue and paint are not included in this kit.
3. When you take parts off the runner frame, use the modeling scissors and trim excess plastic with a cutter or a file.
4. See below for the meaning of symbols.

△組み立ての注意:

1. 接着剤や塗料は火の近くで使わないで下さい、使用の際は換気を良くして下さい。
2. 塗料指定のは下記のとおりです、接着剤や塗料は入っていないので別に求めて下さい。
3. 部品をランナーから切り離す時は模型用ハサミ等を使い、余分な部分はカッターやヤスリ等で仕上げて下さい。
4. 組立図のサインマークは下の説明を御覧下さい。



Fill hole
填平

穴を埋めてください



Apply decal
水印貼紙

デカールをはって下さい



Cut off
切除

切り取って下さい



Cement
胶水

接着してください



Open hole
钻孔

穴をあけて下さい



Do the same
on the opposite

反対側も取り付けます



Bend
弯折

折り曲げて下さい



Make two sets
制作二組

2個作って下さい



No cement
不用胶水

接着しないで下さい



Instant glue
for metal

瞬間接着剤(金属用)



Optional
选擇使用

どちらかを選んで下さい



Be careful
注意

注意して下さい

A PARTS×1

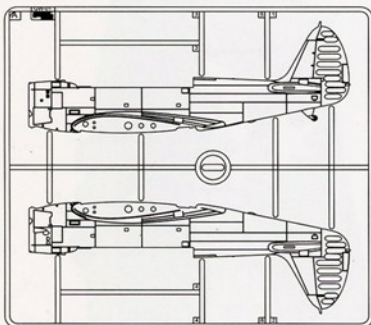

B PARTS×1

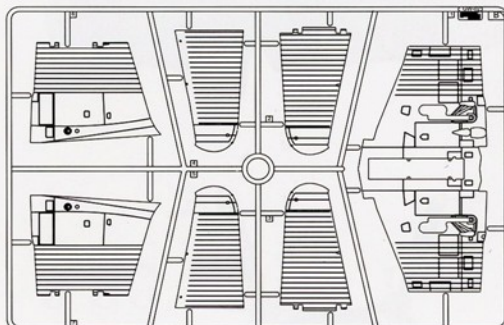

C PARTS×1

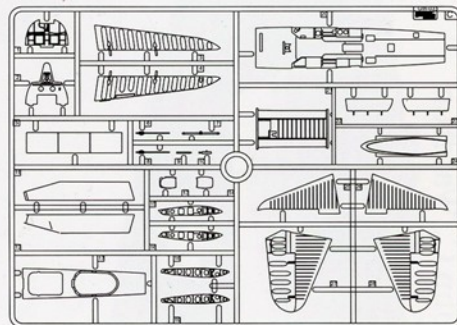

D PARTS×1

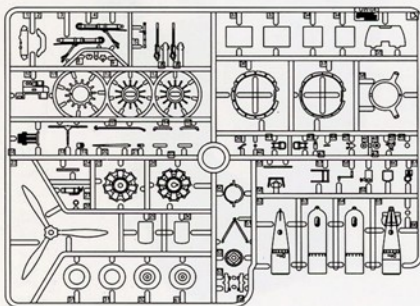

E PARTS×1

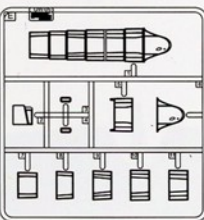

F PARTS×1



ME1 PARTS×1



ME2 PARTS×1



PE A PARTS×1



PE B PARTS×1



DE PARTS×1

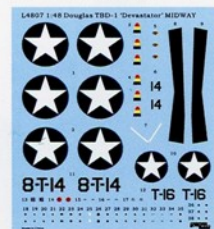

FE PARTS×1

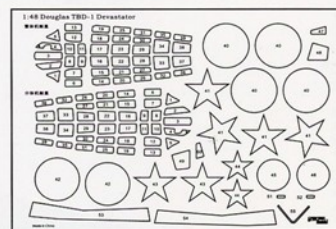

C000 GSI CREOS CORP.HOBBY COLOUR

C 3	926	XF-7	红色	Red
C 5	043	XF-8	蓝色	Blue
C 9	996	X-12	金色	Gold
C 14	005	AS-8	海军蓝	Navy Blue
C 33	073	XF-1	哑黑色	Flat Black
C 43	828	XF-55	木色	Wood
C 92	057	X-18	半光黑	Semi Gloss Black
C324	050	XF-19	浅灰	Light Gray

000 VALLEJO

C 4	915	XF-3	黄色
C 8	997	X-11	银色
C 13	050	XF-53	中灰
C 28	863	X-10	枪铁色
C 42	983	XF-64	深棕色
C 61	865	XF-56	烧铁色
C338	050	AS-7	浅灰

XF-0 TAMIYA

C 4	915	XF-3	黄色	Yellow
C 8	997	X-11	银色	Silver
C 13	050	XF-53	中灰	Neutral Gray
C 28	863	X-10	枪铁色	Steel
C 42	983	XF-64	深棕色	Mahogany
C 61	865	XF-56	烧铁色	Burnt Iron
C338	050	AS-7	浅灰	Light Gray FS36495