

ACADEMY

HOBBY MODEL KITS

# M113A1 A.P.C. VIETNAM

## M113A1 베트남전형



### 1/35th Scale

13266

In production over 30 years, longer than any other armored vehicle, M113 and its many sub-types serve in the armies of more than 50 countries. As this is written, over 40,000 M113's or variants have been built and delivered by FMC or its licensees.

Battle proven in Vietnam, the M113 enabled a ten-man squad of infantry to travel behind protective armor in an amphibious vehicle that carried sufficient weapons to be considered an offensive weapons system. Its ability to ford streams or even cross lakes made it an extremely useful vehicle in the waterlogged jungles of Vietnam.

As experience was gained with the use of the M113 in combat, numerous modifications were made to the vehicle to increase both its firepower and crew protection features.

M132 self-propelled flame-thrower was used by U.S. Army and ARVN units. M132 had a small turret equipped with a flame-gun and machine gun. A number of M113s were also used during the Vietnam war by the Australian armored units. They decided to mount a T50 Cadillac Gage machine gun turret.

The Republic of Korea Army units sent to Vietnam acquired a number of M113s on permanent loan from the U.S. Army. The Korean Army's M113s did not have original designed gun shield kits as applied to U.S. Army's one. Instead, they did without the gun shield for the .50 caliber and had heart-shaped armored shields for the two .30 caliber light machine guns fired from rear personnel compartment.

30여년이라는 오랜 기간 동안 40,000대가 넘는 엄청난 수량의 M113과 그 개수형들이 FMC(Ford Motors Corporation)와 라이센스 생산을 통해 양산되어 50여개국에 넘는 나라의 육군에 배치되었다. M113은 공격무기 시스템을 포함한 충분한 무장을 장비한 수륙양용차량으로 방탄 장갑판 속에 10명의 보병 1개 분대를 탑승시킨 채 작전을 충분히 수행할 수 있다는 것이 베트남전의 전훈을 통해 증명되었고, M113의 뛰어난 도강 및 도하 능력은 베트남의 질퍽한 정글 지대에서 매우 유용한 것으로 평가되었다. 실전을 치룬 M113의 경험에 의하여, 수많은 개수가 화력과 승무원의 방호력의 증강을 위주로 행하여지게 되었는데, 그 중 특징적인 몇가지 모델을 본 키트에서는 선택 조립할 수 있도록 모형화하였다. 그 내용을 간략히 알아보자.

화염방사기와 기관총이 장착된 소형포탑을 전차장 큐포라 대신 이식한 M132 자주(自走)화염방사 장갑차는 미육군과 남베트남군이 주로 사용하였고, M113을 베트남전 기간 동안 다양 운용한 호주군은 기존의 큐포라 대신 캐딜락 게이지제의 T50 총탑으로 교체하여 실전에 투입한 바 있다.

베트남전에 참전한 한국군 또한 미육군의 영구 임대를 통해 도입한 M113을 사용하였다. 한국군의 M113은 미육군에 장착되었던 기총 장갑을 채용하지 않고, 장갑판이 없는 상태의 기본사양의 캘리버 50 기관총과 특유의 하트 모양의 캘리버 30용 장갑판을 장비한 것이 특징이다.



점착한다.  
Cement parts  
Coller  
Kleben  
Pegar  
Incollare  
Colar  
Kleven



점착하지 않는다.  
Do not cement  
Ne pas coller  
Nicht kleben  
No pegar  
Non incollare  
Nao colar  
Niet kleven



수만큼 조립한다.  
Repeat operation  
Répéter l'opération  
Vorgang wiederholen  
Repitir la operacion  
Ripetere  
Repitir a operação  
Herhalen



전사지를 붙인다.  
Decals  
Decalcomanias  
Abziehbild



무게추를 넣는다.  
Add weight  
Lester  
Gewicht



구멍이나 홈을 채워준다.  
Use filler  
Mastiquer  
Schleifen



잘라낸다.  
Cut away  
Couper  
Schneiden  
Cortar  
Tagliare  
Cortar  
Snijden



선택한다.  
Optional parts  
Choix  
Auswahlmöglichkeit  
Eleccion  
Scelta  
Opcao  
Keuze



반대쪽도 조립한다.  
Repeat for opposite side  
Répétition de la page  
Wiederholung für gegenüberliegende Seite



구멍을 뚫어준다.  
Make hole  
Faire un trou  
Offnen



주의한다.  
Be careful  
Faire attention  
Hier Vorsicht



색칠 및 전사지 붙이기 번호  
Painting scheme number  
Numeros de la liste de peintures  
Lackierschemanummer

**<READ THIS BEFORE YOU BEGIN>**

- Study the instructions before assembling. - Check the fit of each piece before cementing into place.
- Do not use too much cement to join parts. - Never use cement or paint near open flame.
- Open a window or make area well ventilated when cement or paint is in use.
- Tear up and throw away the empty plastic bags to avoid danger of suffocation for little children.

**<ALLGEMEINE HINWEISE>**

- Die Anordnung der Bauteile ist aus den Zeichnungen der Anleitung ersichtlich.
- Die Teile vor dem Verkleben ungeleimt zusammenhalten, um ihren paß zu prüfen.
- Klebstoff nicht zu dick auftragen. - Klebstoff und Farben niemals in der Nähe einer Flamme verwenden.
- Während der Bemalung mit Spritzpistole oder Pinsel für frische Luftzufuhr, z.B. öffnen des Fensters, sorgen.
- Bausatz von kleinen Kindern fernhalten. Verhüten Sie, daß Kinder irgendwelche Bauteile in den Mund nehmen oder Plastiktüten über den Kopf ziehen.

**■ 조립하기 전에**

- 부품을 조립하기 전에 설명서를 잘 읽어본 후 조립한다. - 부품을 자를 때에는 칼이나 니퍼로 깨끗이 잘라준다. - 접착제를 사용할 곳과 사용하지 않는 곳에 주의하고 너무 많이 바르지 않도록 한다.
- 접착하기 전에 부품을 맞추어 확인한 후 조립한다. - 에나멜 페인트나 접착제를 사용할 때는 창문을 열어 환기를 시키고 화기를 멀리한다. - 사용 후 남은 부품은 어린 아이들의 손에 닿지 않도록 잘 처리한다.



**<LISEZ CE QUI SUIT AVANT DE COMMENCER LE MONTAGE>**

- Étudier les schémas d'assemblage. - Contrôler que chaque pièce soit bien conforme avant de la coller à sa place.
- N'utilisez pas trop de colle pour réunir les pièces. - Ne jamais manipuler la colle ou peinture à proximité d'une flamme.
- Utilisez soigneusement la pièce où vous peignez (ouvrez la fenêtre).
- Après avoir sorti les pièces du sac en plastique, déchirez le sac afin d'éviter que les enfants ne le mettent sur la tête et ne s'étouffent.

**<組み立てる前に>**

- 組み立てる前に説明書をお読み下さい。 - 部品をランナーから切りはずす時は模型用ニッパーとカッターを使用します。
- 接着剤を少なめに使うことがきれいに仕上げるコツです。 - 接着する前に部品を合わせて確かめます。
- 接着剤や塗料を使用する時はときどき窓を開けて換気をお願いします。
- 組み立て後の部品やビニール袋は小さな子供の手の届かない安全所に保管して下さい。

1

**■ Choose between the Royal Australian Army Version, M132A1 Flamethrower, R.O.K Army Version, & U.S. M113A1 ACAV with 106mm R.R.**  
이 키트는 호주군 사용차량과 M132A1 화염방사차량, 한국군 명호부대 사용차량, 그리고 미군 ACAV 106mm 무반동총 탑재차량으로 선택하여 조립할 수 있습니다.

- Do not cement 접착제 사용금지.
- Cement 접착제 사용.

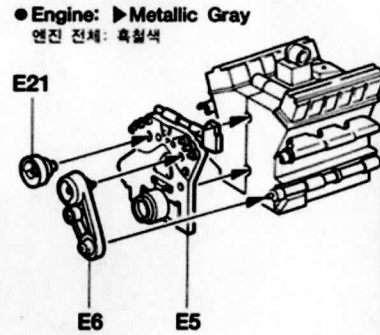
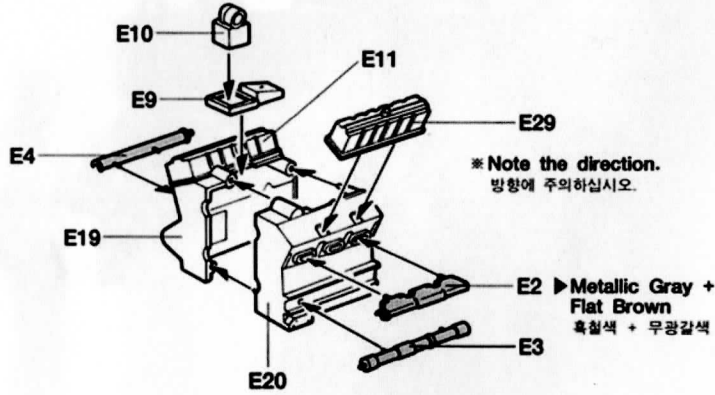

2

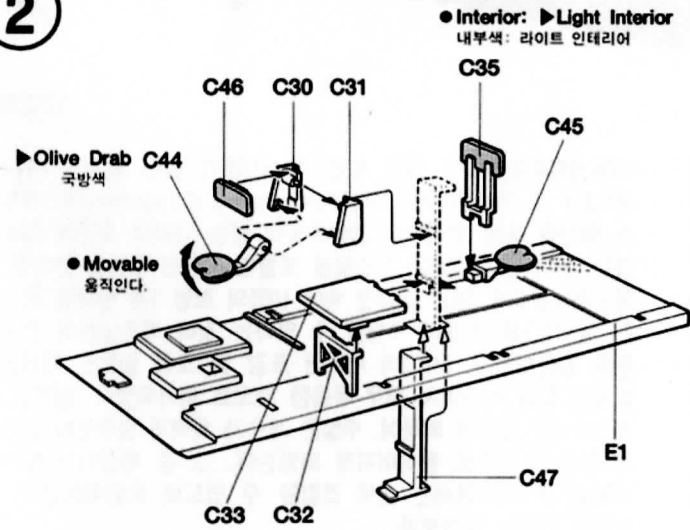

3

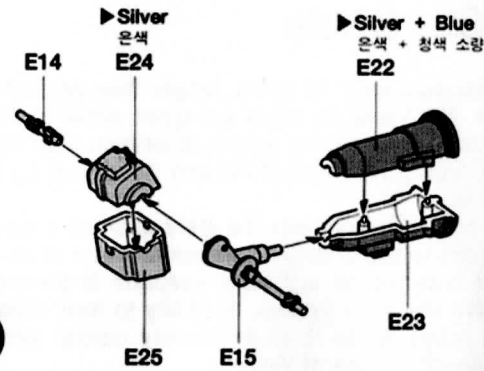

4

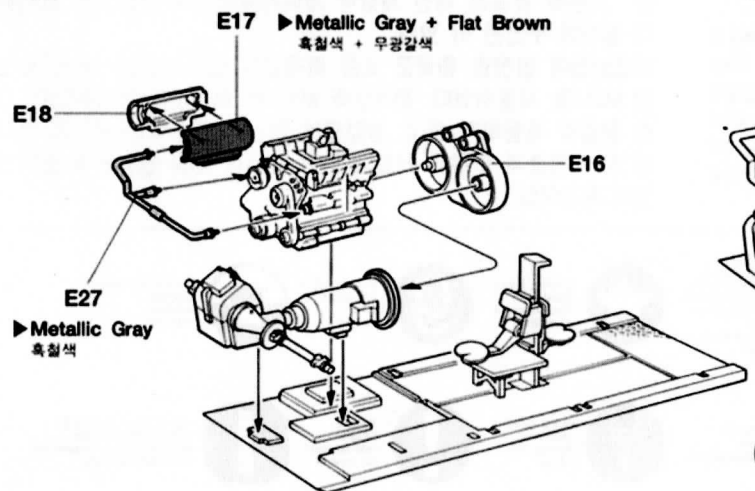

5

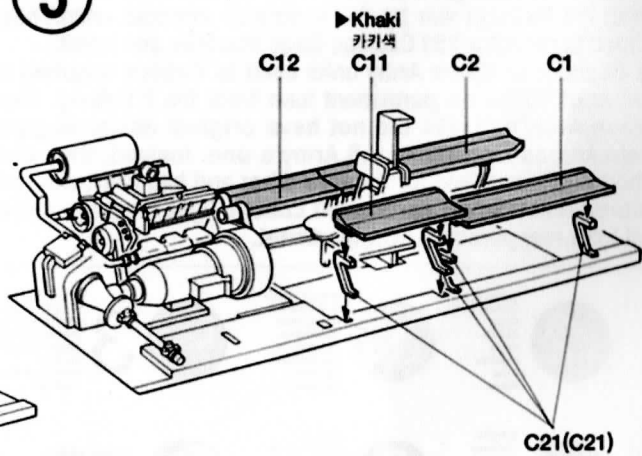

● ( ) is opposite number. ( ) 안의 번호는 반대편 부품번호임.

6

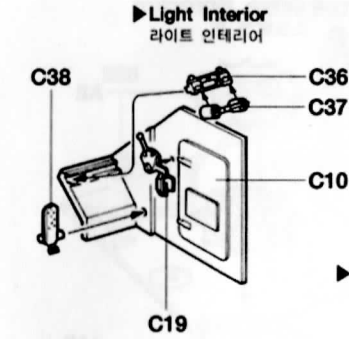

**Interior: ▶ Light Interior**

내부색: 라이트 인테리어

▶ Flat Black 무광 검정색

7

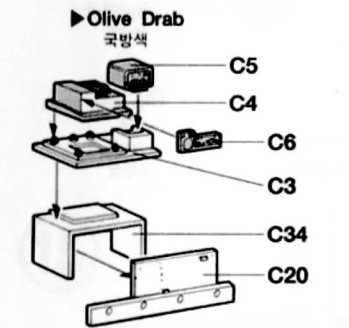

▶ Olive Drab 국방색

8

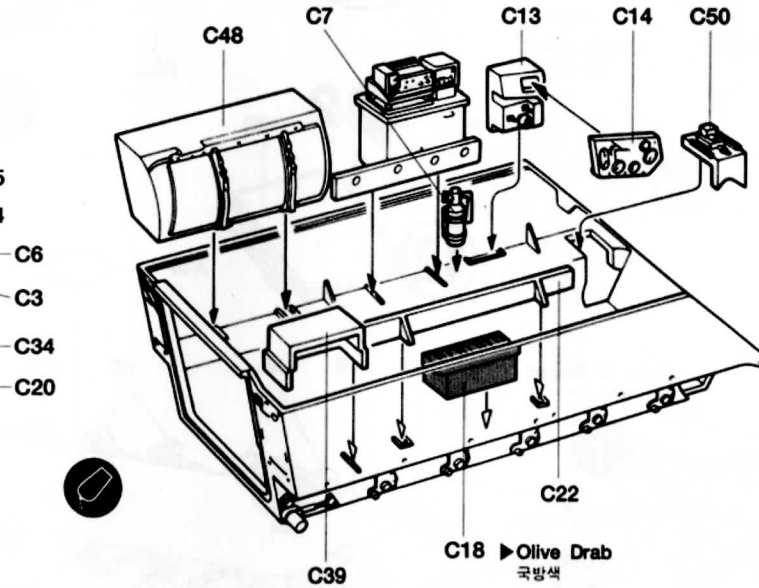

9

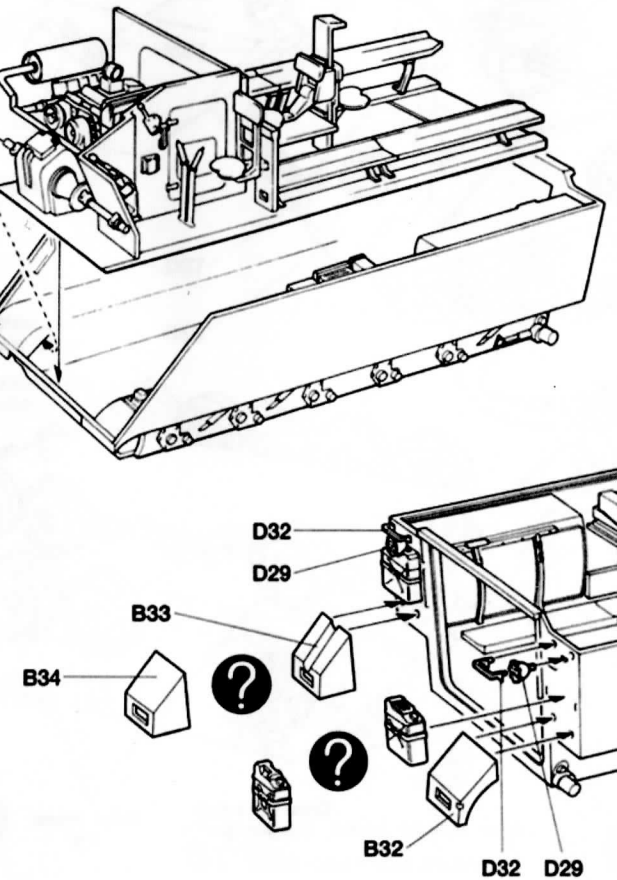

**■ Decal apply 전사지 붙이기**

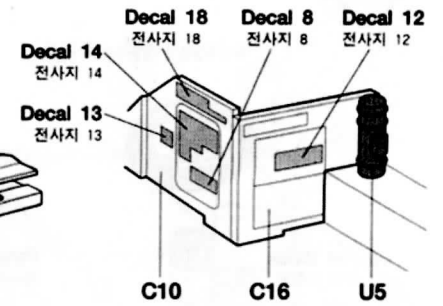

● Apply decals after painting. 색칠 후 전사지를 붙인다.

**■ Painting C14 계기판(C14)의 색칠**

▶ Flat Red 무광 빨강색

▶ Flat Black 무광 검정색

**■ Painting C7 소화기(C7)의 색칠**

▶ Silver 은색  
▶ Flat Black 무광 검정색  
▶ Flat Red 무광 빨강색

2

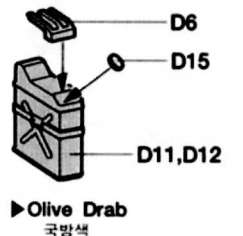

▶ Olive Drab 국방색

2

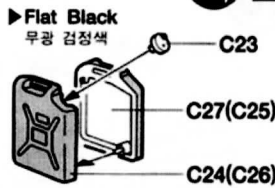

● ( ) is opposite number. ( ) 안의 번호는 반대편 부품번호임.

**■ Painting D29 미등(D29)의 색칠**

▶ Flat Red 무광 빨강색  
▶ Flat Black 무광 검정색

10

■ Road Wheel 전륜

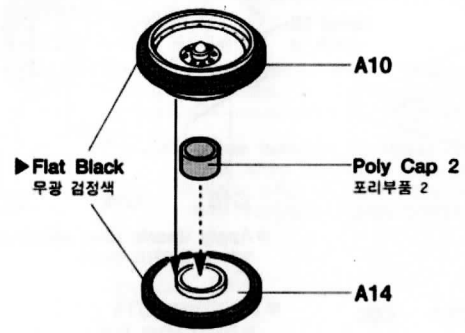

10

■ Idler Wheel 아이들러 휠

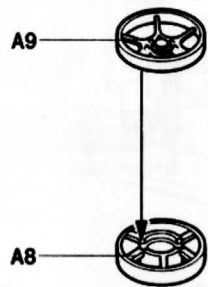

2

■ Drive Sprocket 스프로킷 휠

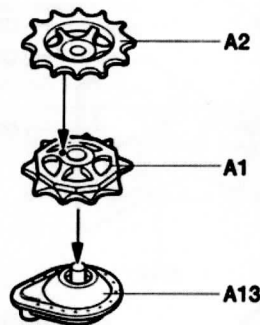

2

11

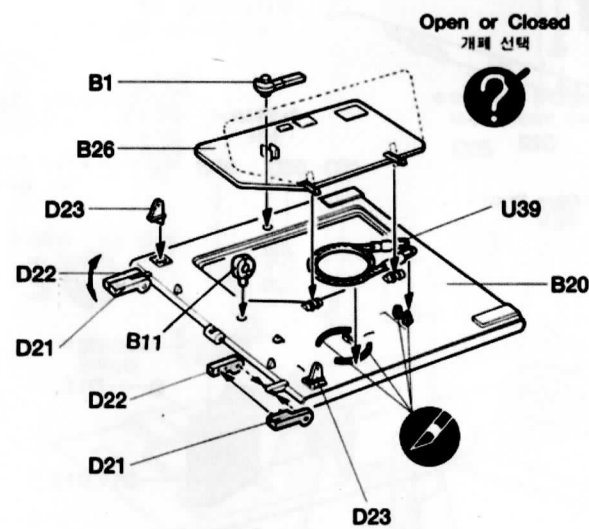

13

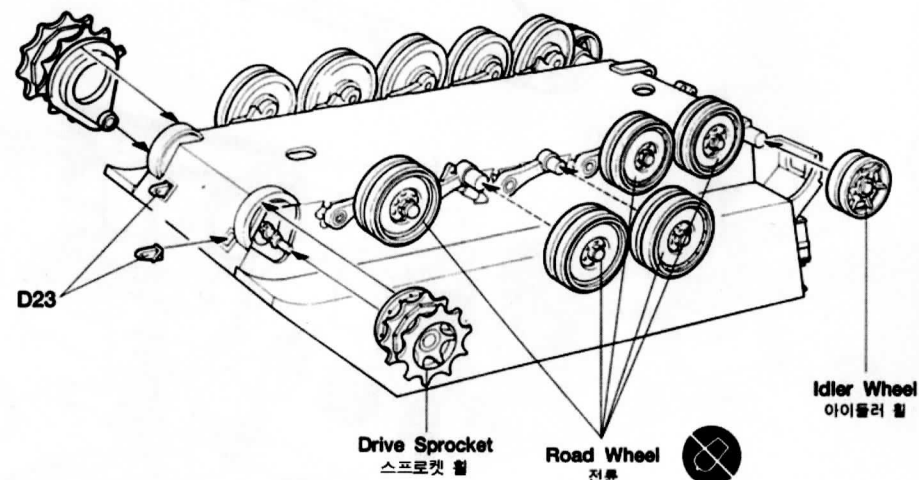

12

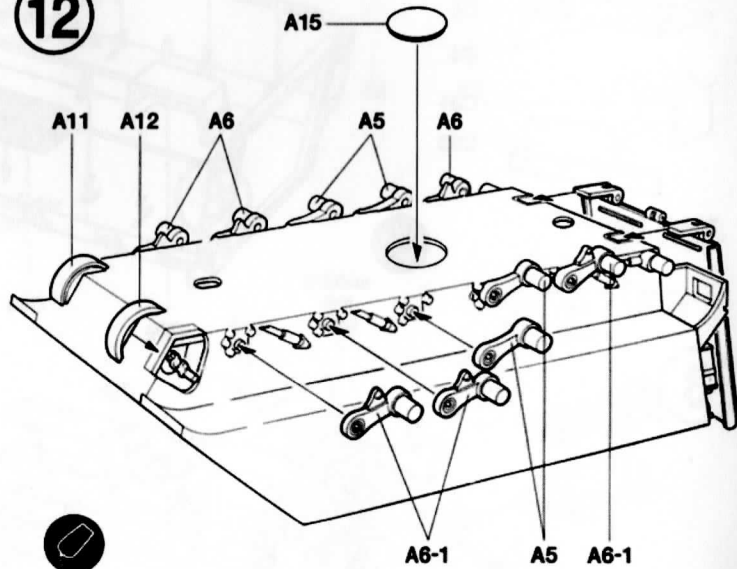

14

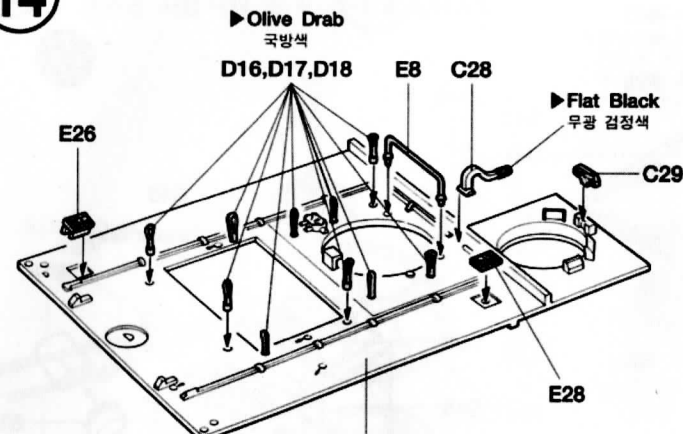

■ Painting C29  
검고등(C29)의 색칠

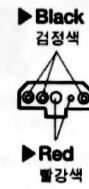

15

■ Flexible Tracks  
연질 캐터필러

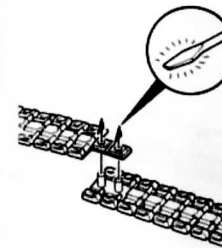

Melt pin heads with a heated screw driver blade and immediately press pin head by finger.  
캐터필러를 연결하고 불에 달군 드라이버로 핀을 약간 녹인 후 바로 손가락으로 눌러준다.

■ Individual Tracks  
연결식 캐터필러

From the tracks within 30-60 minutes of applying cement.  
캐터필러를 연결시킨 후 접착제가 완전히 마르기전 인 30분-1시간 사이에 조심스럽게 알맞은 형태로 구부려 조립한다.

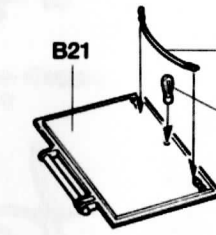

■ Painting B27  
조명라이트(B27)의 색칠

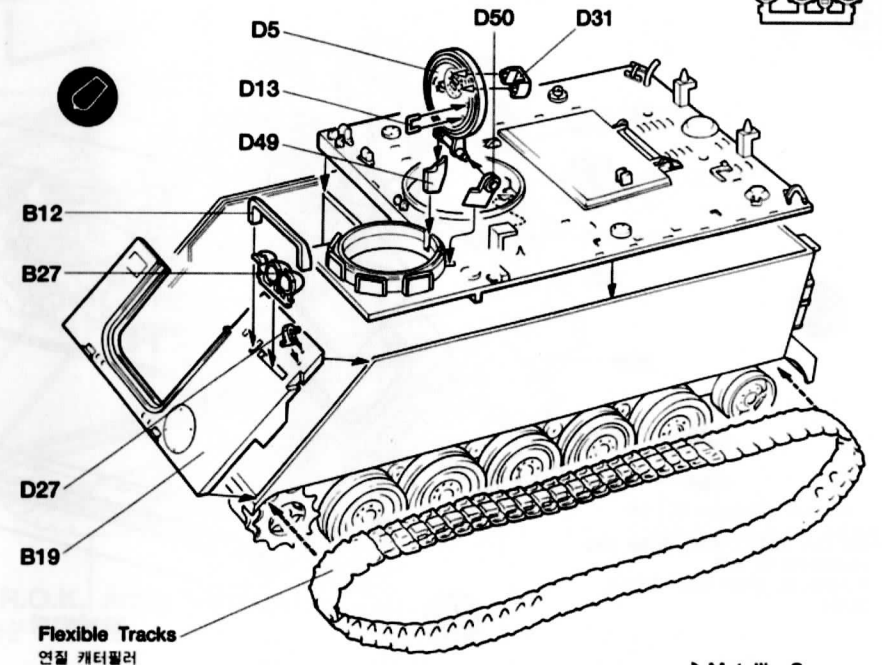

Flexible Tracks  
연질 캐터필러

■ Flat Black 무광 검정색  
Metallic Gray 흑갈색

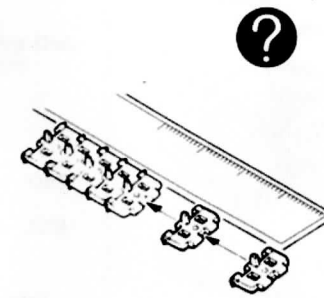

Assemble the tracks against edge as shown.  
자동을 이용하여 비틀어지지않게 연결한다.



16

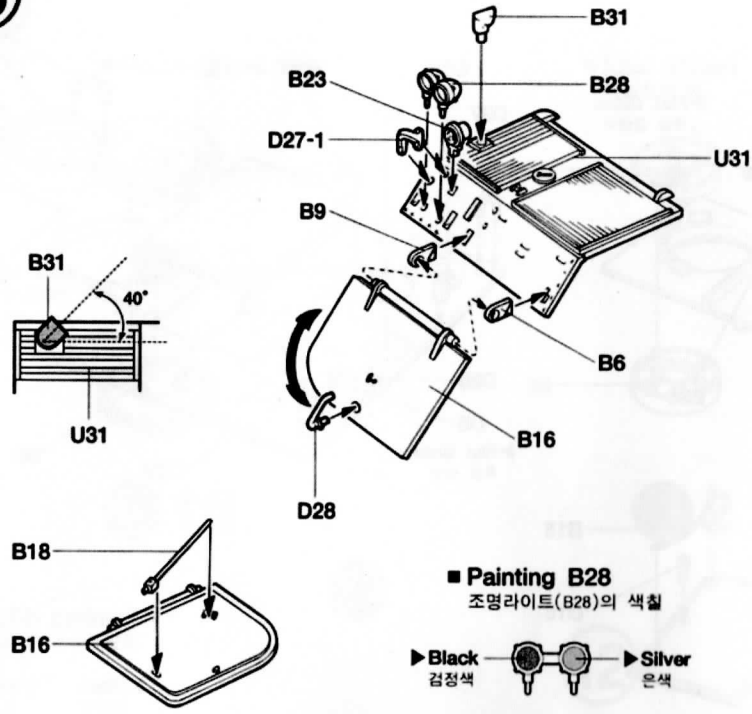

■ Painting B28  
조명라이트(B28)의 색칠

▶ Black 검정색    ▶ Silver 은색

17

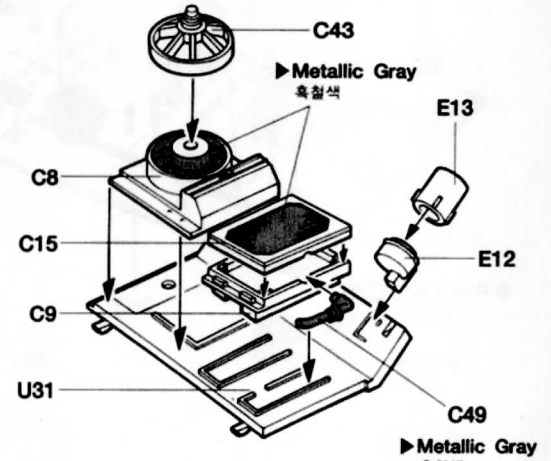

▶ Metallic Gray 흑철색  
\* Do not fix C49, when you assemble closed position.  
닫힌 상태에서는 C49를 조립하지 않는다.

18

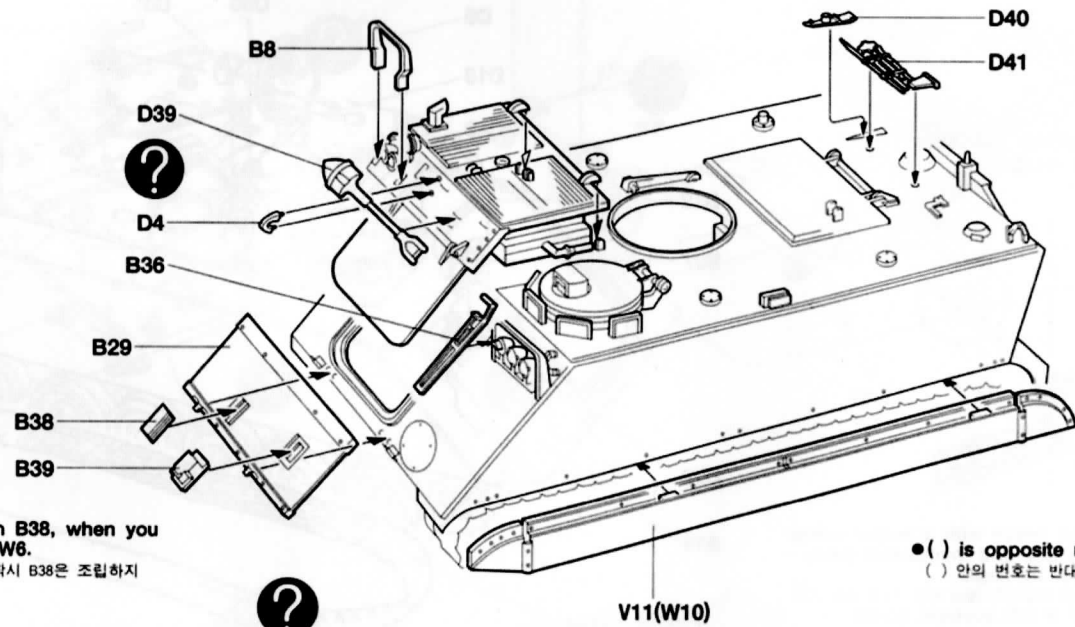

\* Do not attach B38, when you assemble to W6.  
중가장갑(W6) 장착시 B38은 조립하지 않는다.

● ( ) is opposite number.  
( ) 안의 번호는 반대편 부품번호임.

Open or Closed  
개폐 선택

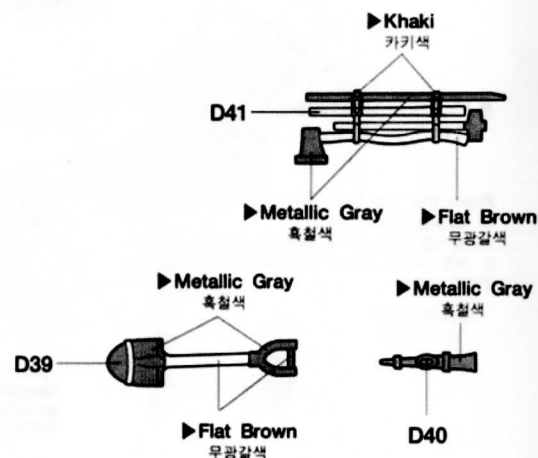
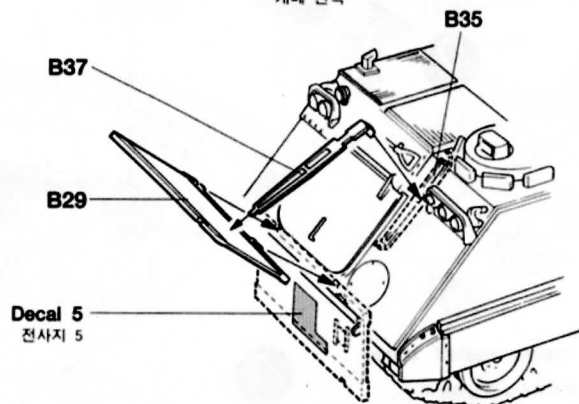

19

Royal Australian Army Version & M132A1 Flamethrower

호주군 사용차량 및 M132A1 화염방사형

\* Choose between the Royal Australian Army Version, M132A1 Flamethrower, R.O.K Army Version, & U.S. M113A1 ACAV with 106mm R.R.  
이 키트는 호주군 사용차량과 M132A1 화염방사차량, 한국군 영호부대 사용차량, 그리고 미군 ACAV 106mm 무반동총 탑재차량으로 선택하여 조립할 수 있습니다.

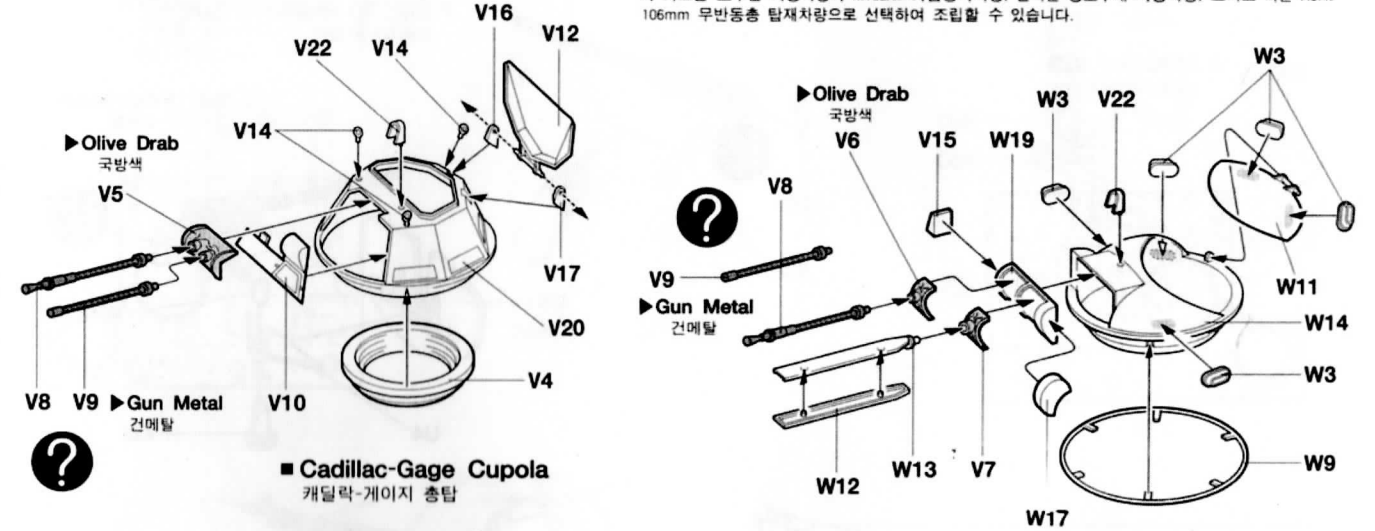

■ Cadillac-Gage Cupola  
캐딜락-게이지 총탑

■ Flamethrower Cupola  
화염방사 총탑

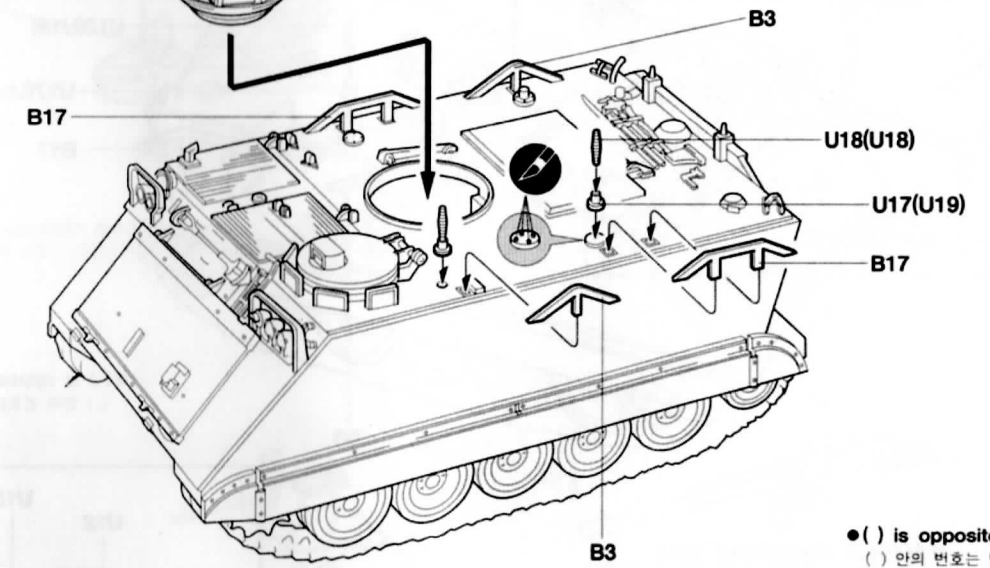

● ( ) is opposite number.  
( ) 안의 번호는 반대편 부품번호임.

20

U.S. M113A1 ACAV & R.O.K. Army Version

M113A1 미군 사용차량 및 한국군 사용차량

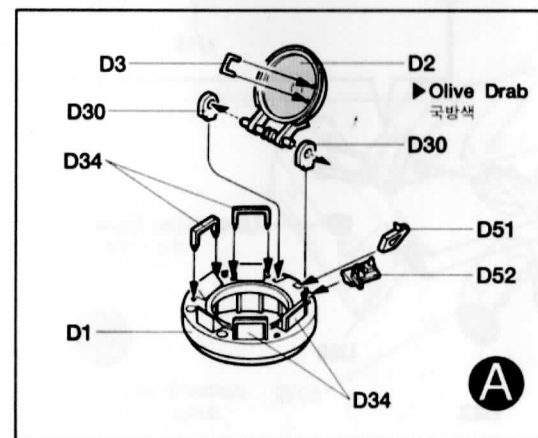

■ Cal. 50 Machine Gun  
Cal. 50 기관총

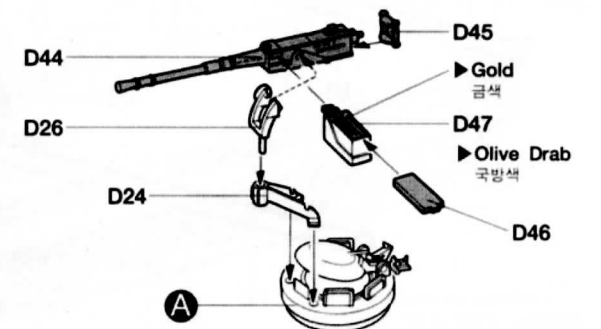

21

R.O.K. Army Version  
한국군 맹호부대 사용차량

Attached V23  
V23의 부착위치

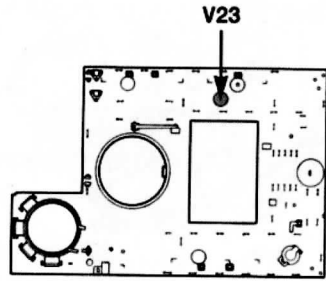

Cal. 30 Machine Gun  
Cal. 30 기관총

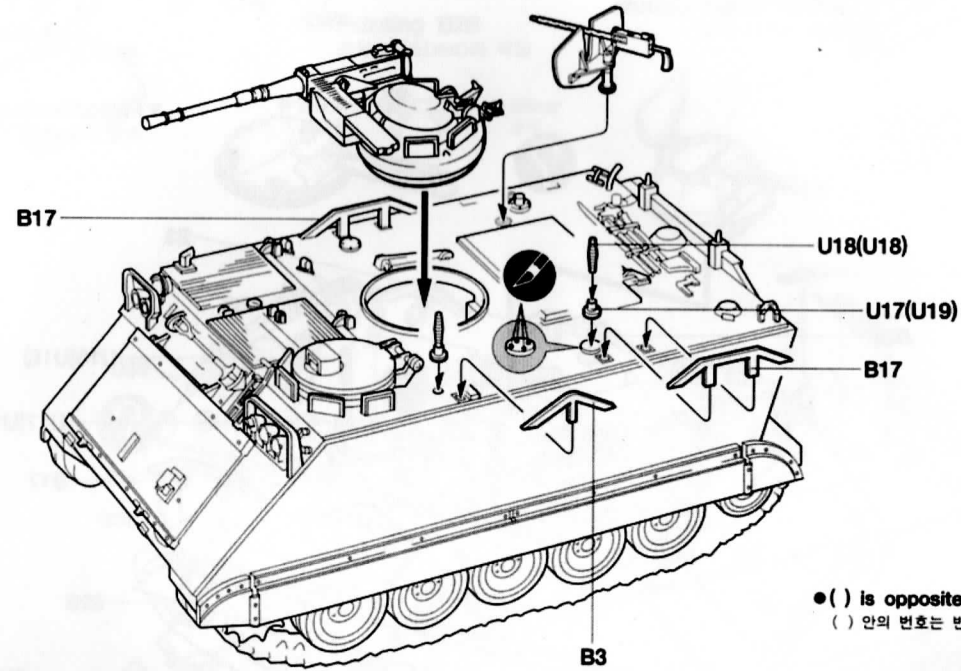
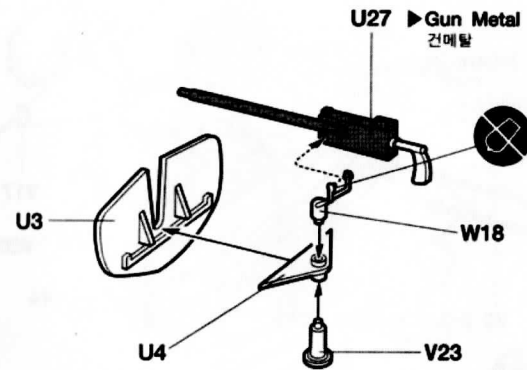

( ) is opposite number.  
( ) 안의 번호는 반대편 부품번호임.

22

106mm Recoilless Rifle  
106mm무반동총

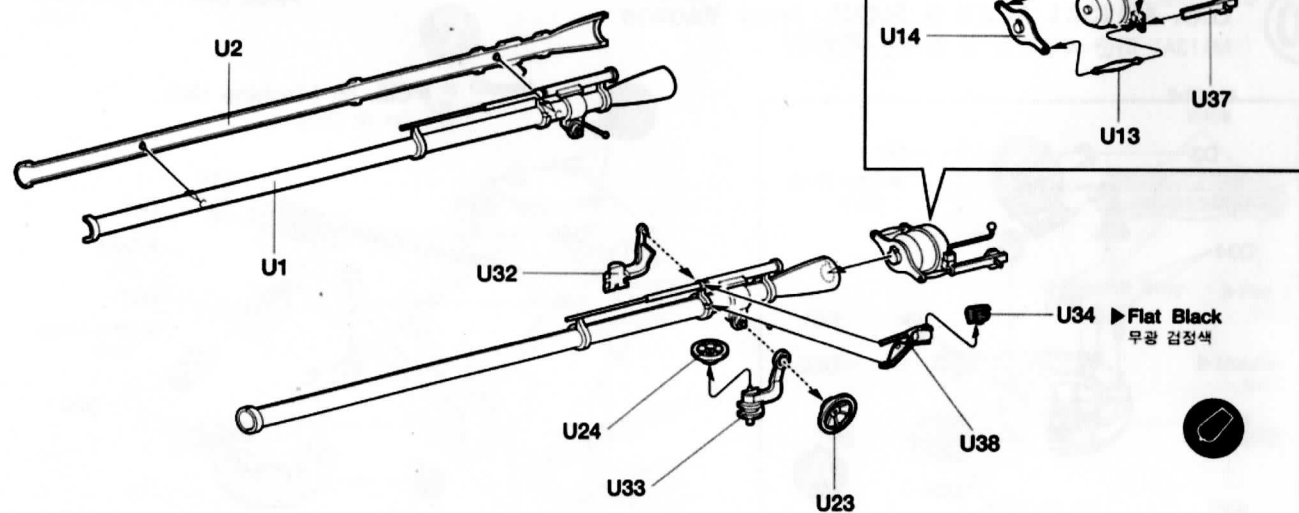

23

U.S. M113A1 ACAV  
M113A1 ACAV 미군 사용차량

Make Holes  
구멍을 뚫어준다.  
U6: 1mm, U33: 2.5mm

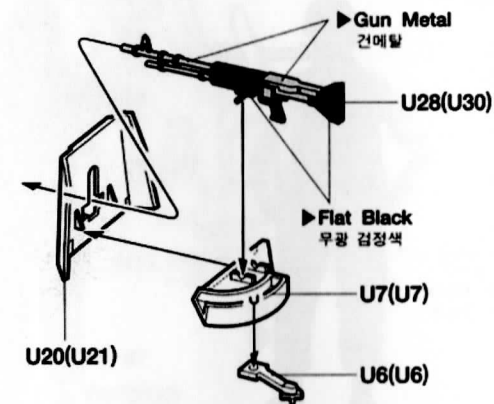
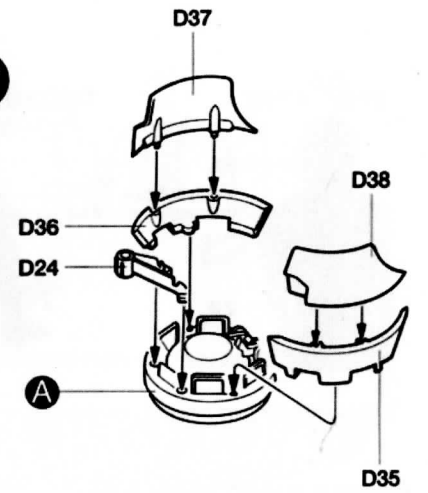
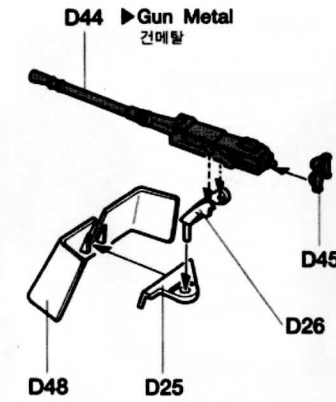
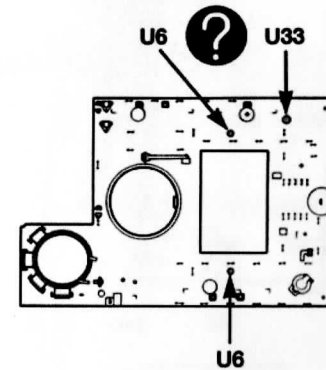

( ) is opposite number.  
( ) 안의 번호는 반대편 부품번호임.

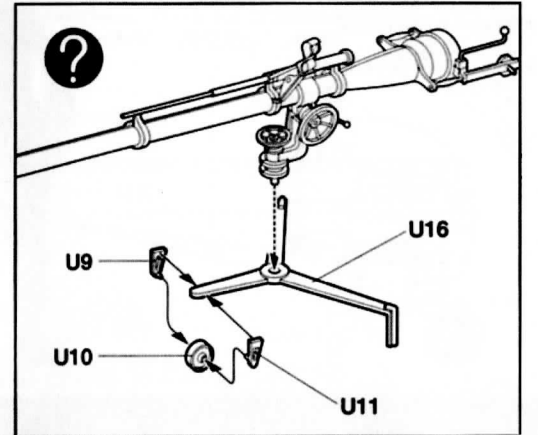

2

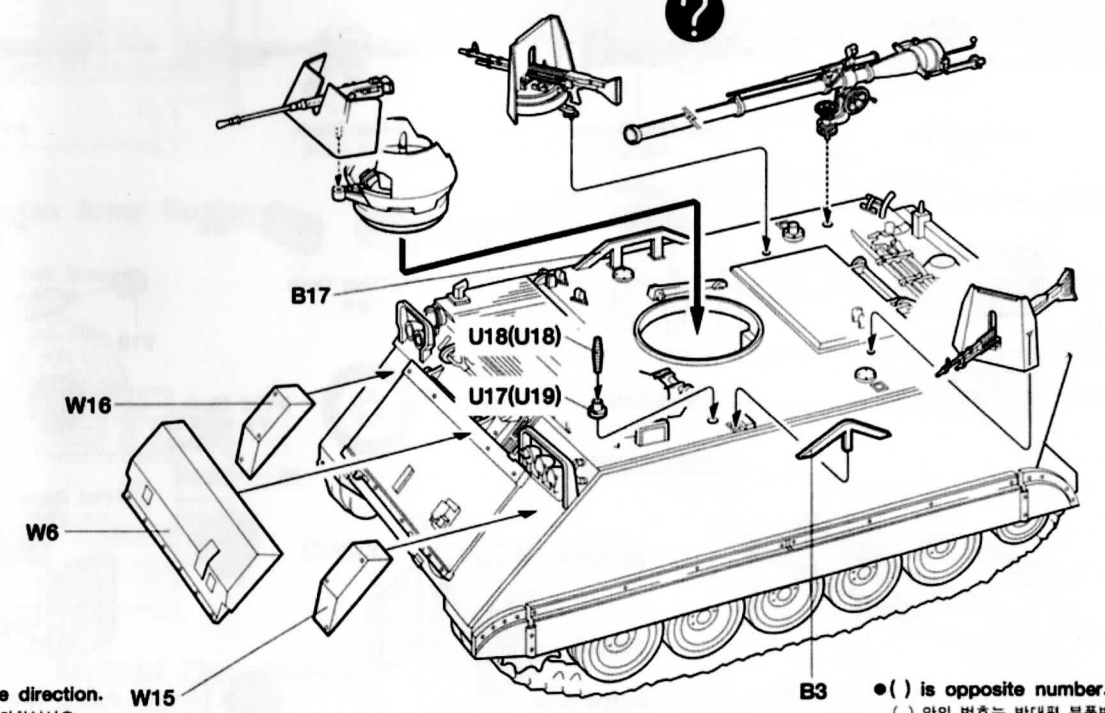

\* Note the direction.  
방향에 주의하십시오.

( ) is opposite number.  
( ) 안의 번호는 반대편 부품번호임.





**A**

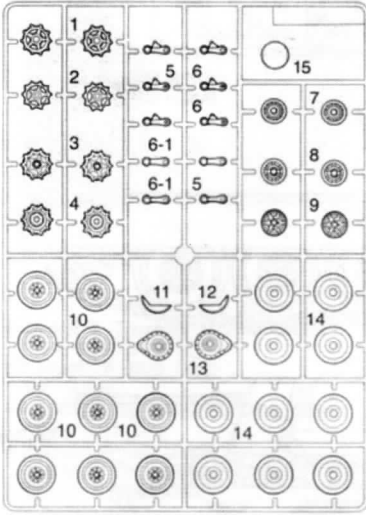

**B**

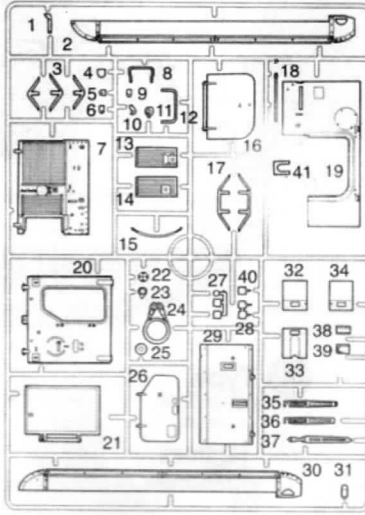

**C**

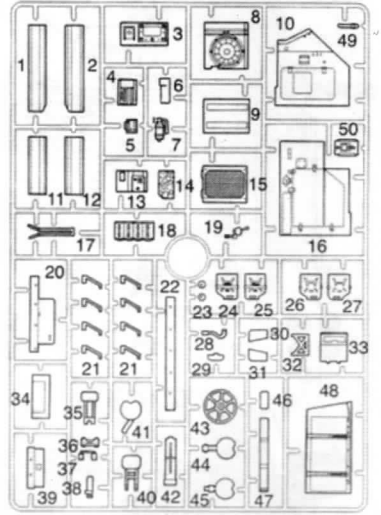

**D**

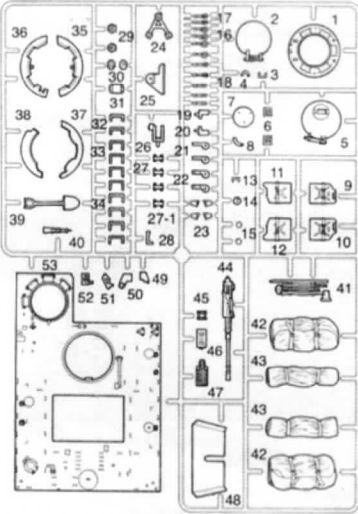

**E**

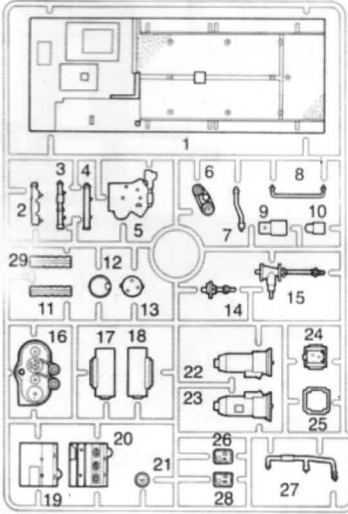

**U**

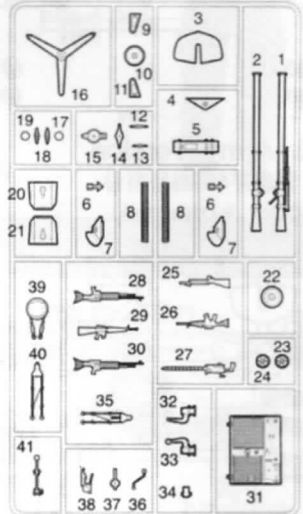

**V**

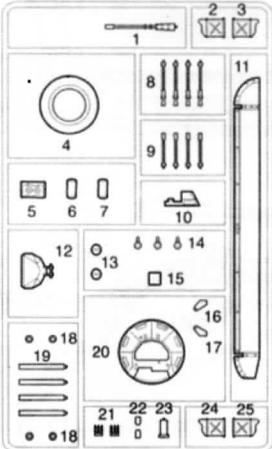

**W**

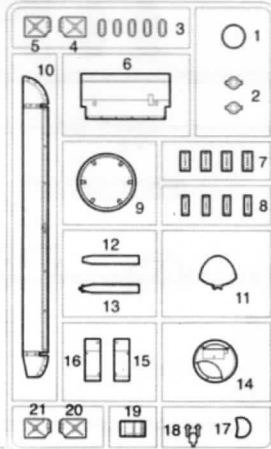

Lower Hull×1, Poly cap×1, Flexible track×2,  
Individual track(X part)×2, Clear part(G part)×1,  
Figure part(Y,Z part)×1 each, Decal×1, Instructions×1  
하체×1, 폴리부품×1, 연결 캐터필러×2, 연결식 캐터필러(X 파트)×2,  
투명(G)파트×1, 인형(Y,Z)파트×각1, 전사지×1, 설명서×1

●Unused Parts 불필요 부품  
A3, A4, A7, B2, B4, B7, B13, B14, B22,  
B24, B25, B30, B40, B41, D7, E7  
Poly cap 1.2×2 폴리부품 1.2종 ×2개

**ACADEMY**  
HOBBY MODEL KITS

**ACADEMY**  
ACADEMY PLASTIC MODEL CO., LTD.  
521-1, Yonghyeon-dong, Uijeongbu-si, Gyeonggi-do, Korea  
고객상담문의 : 080-969-7000