

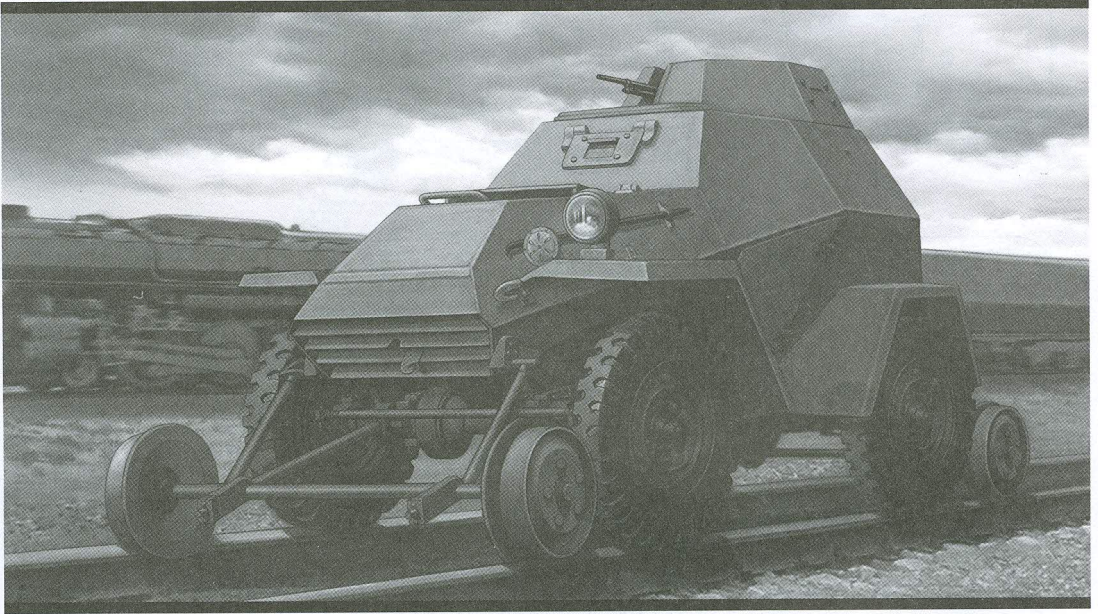

VM35004 1/35 SCALE

Soviet BA-64Zhd

蘇軍BA-64Zhd鐵道型裝甲車



In the Soviet Union the GAZ-64 field car performed the same function as the American Jeep. It was built in large numbers and the chassis was used to produce the BA-64 armoured car. The BA-64 became the standard light armoured car of the Red Army from early 1942 replacing the BA-20. It was supplied in large numbers and was also used by Soviet client states for many years after the war. To protect the vast Railroad network used to transport supplies, the Red Army employed armoured trains and converted armoured cars to run on railroad tracks. The BA-64Zhd was based on a standard BA-64B armoured car, but with the road wheels removed and replaced by steel disk carriage wheels. But unfortunately the machine gun armament was too light for practical use and no production followed.

Phil Greenwood

蘇聯的Gaz-64 人員輸送車與美軍吉普車的性能相若。它被大量生產而底盤更被用來改進作為 BA-64 裝甲車使用。從 1942年初開始BA-64 成為紅軍的標準輕型裝甲車用以取代老舊的BA-20。它被大量生產而且在二戰後，更被蘇聯提供給其他友好國家使用。紅軍使用大量的裝甲列車或轉換鐵輪能在鐵軌上行走的裝甲車作為保護其龐大的鐵道網絡及用來輸送供應品。Gaz-64Zhd就是改裝自標準的BA-64B 裝甲車，其路輪則用鋼輪代替橡膠車輪。但不幸的是由於其裝備之機槍武裝實際過弱引致後來沒有大量生產

Parts:

A13 x1

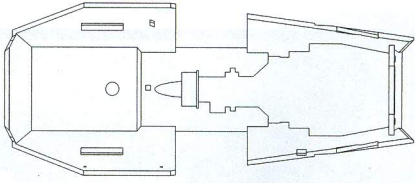

A14 x1

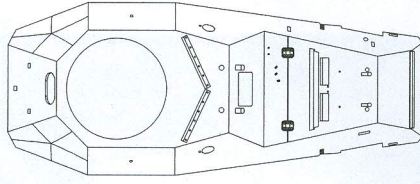

C1x5

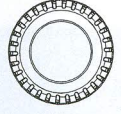

Ax1

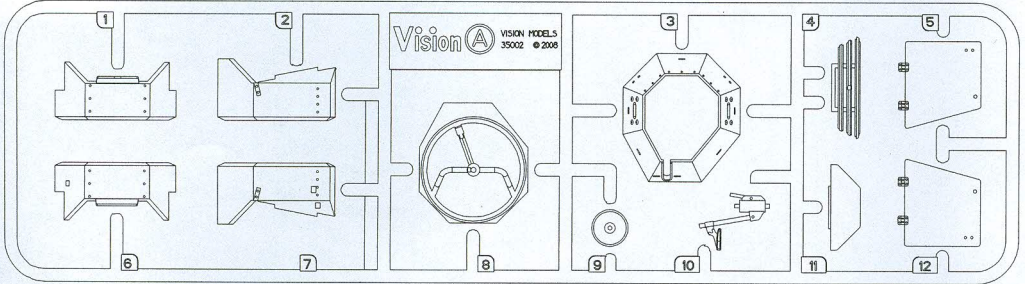

Bx1

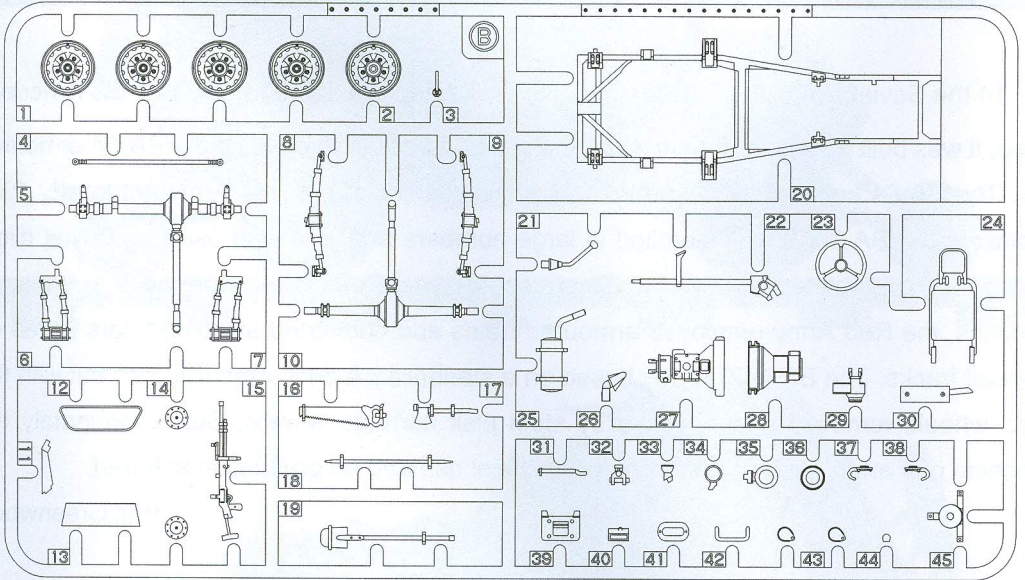

Lx1

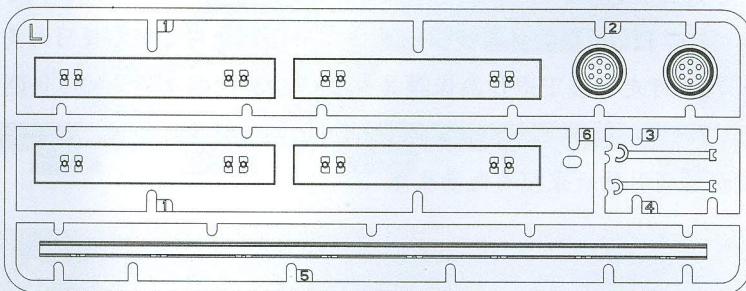

Lax1

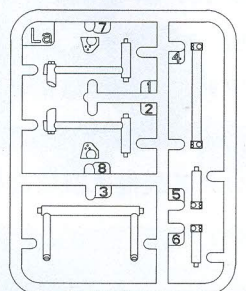

1

body color : Russian green

or

Olive drab

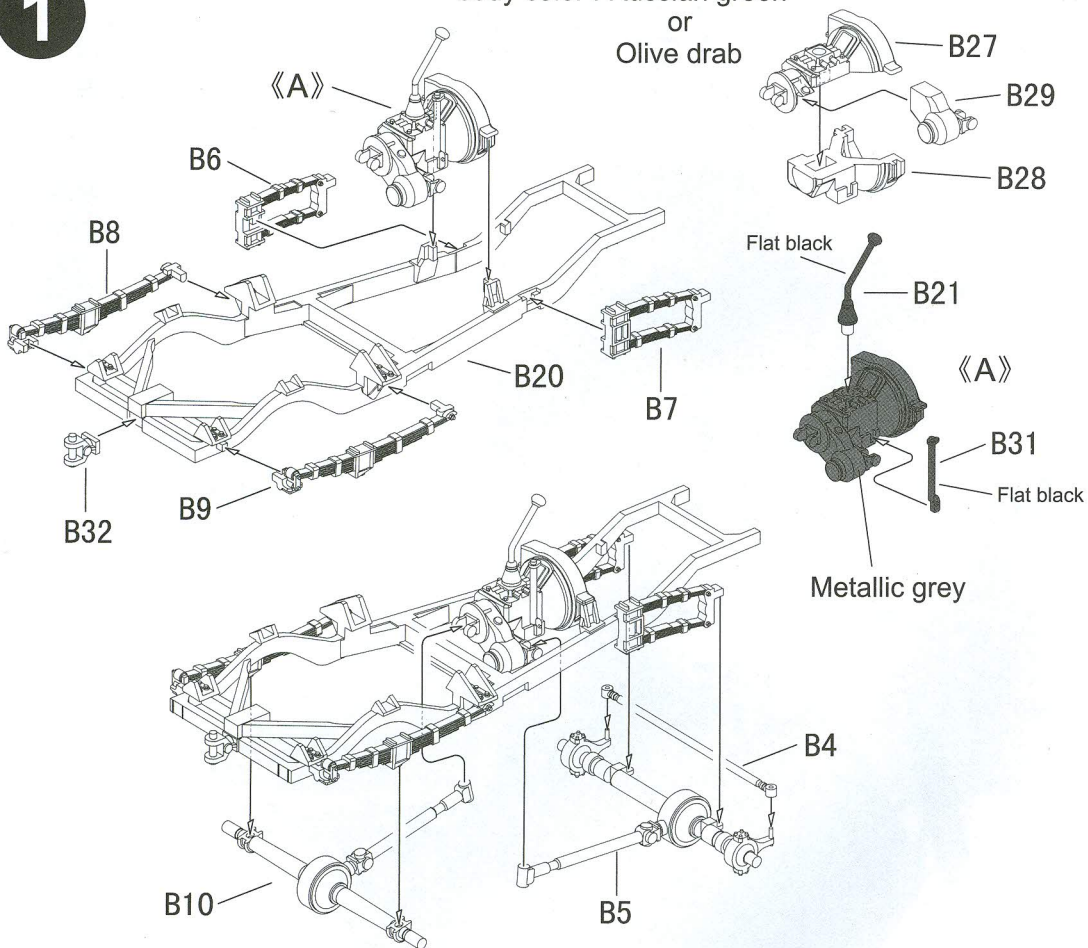
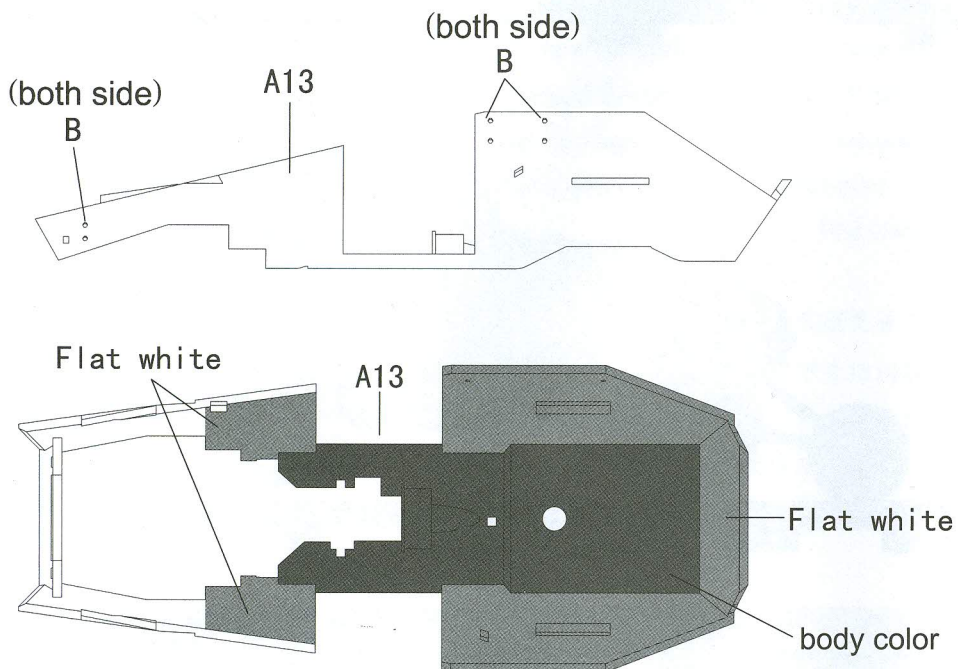
**2****3**

3

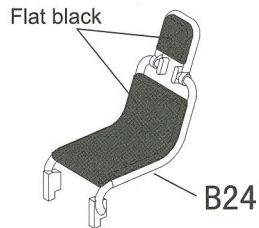
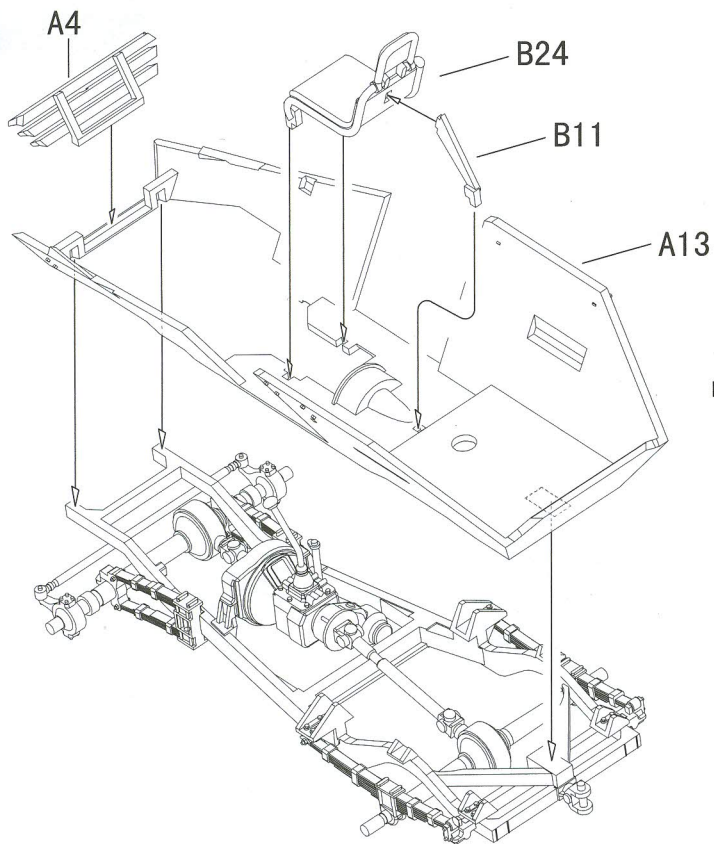

4

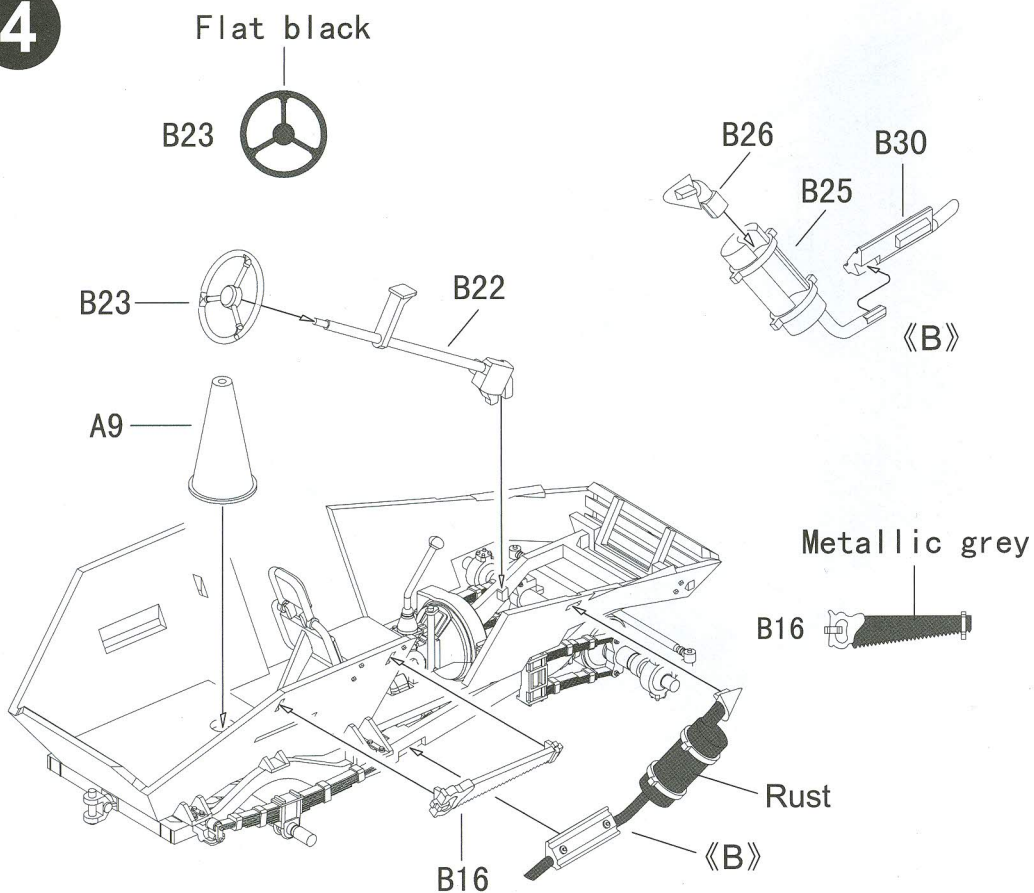

4

5

B17
Metallic grey

B18
Metallic grey

B19

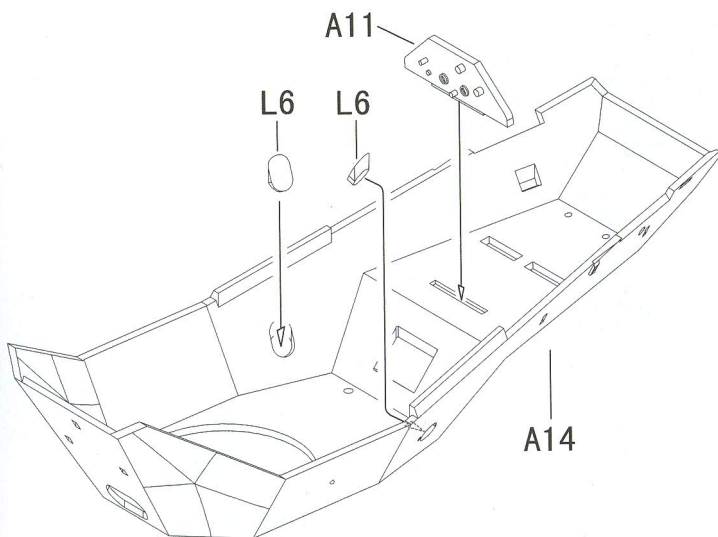

Flat white
A11
Flat black

6

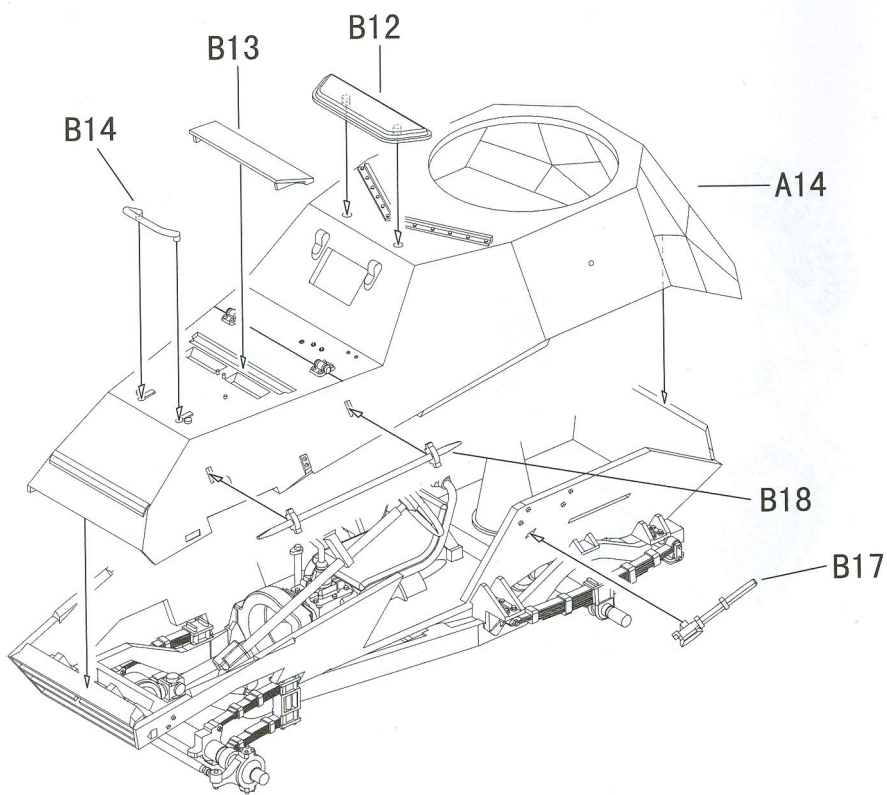

5

7

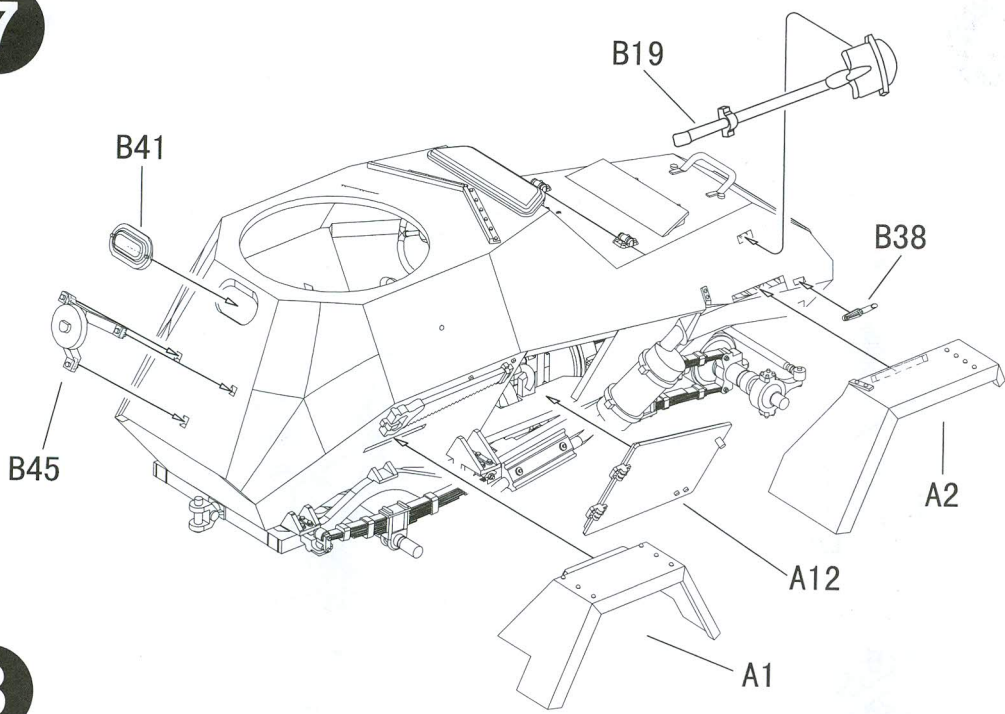

8

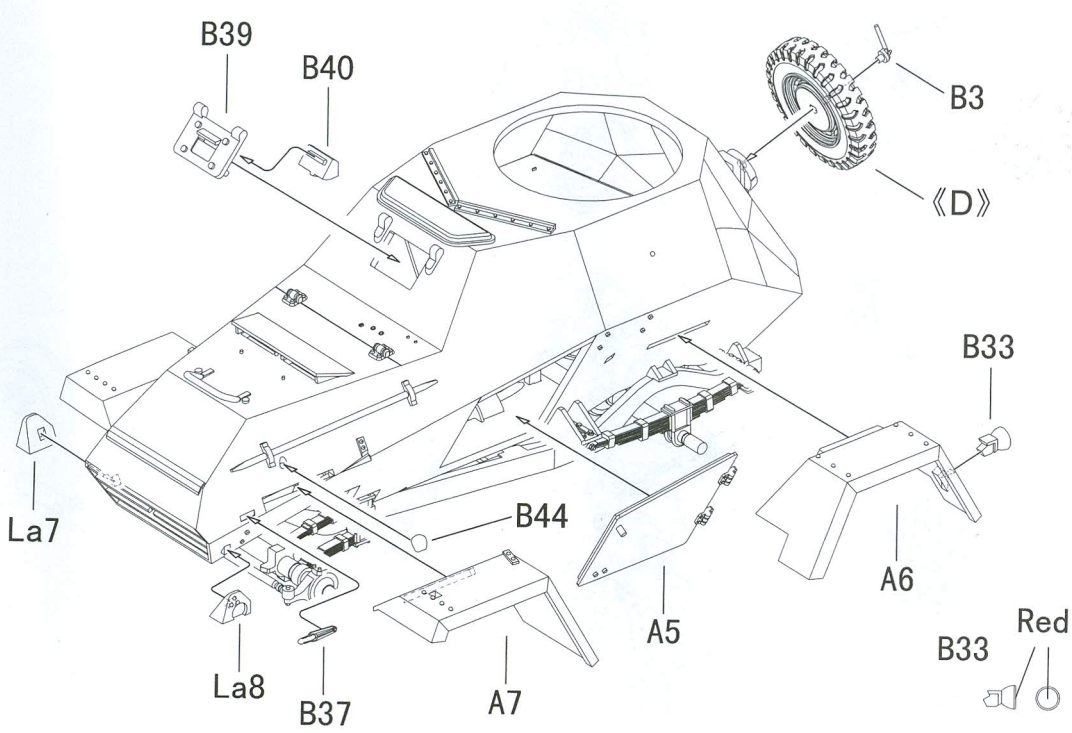
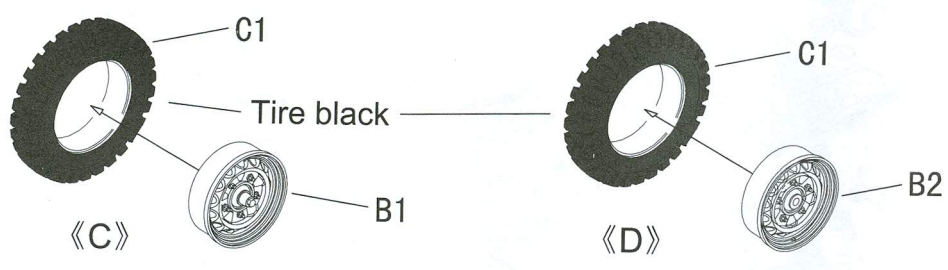

6

9

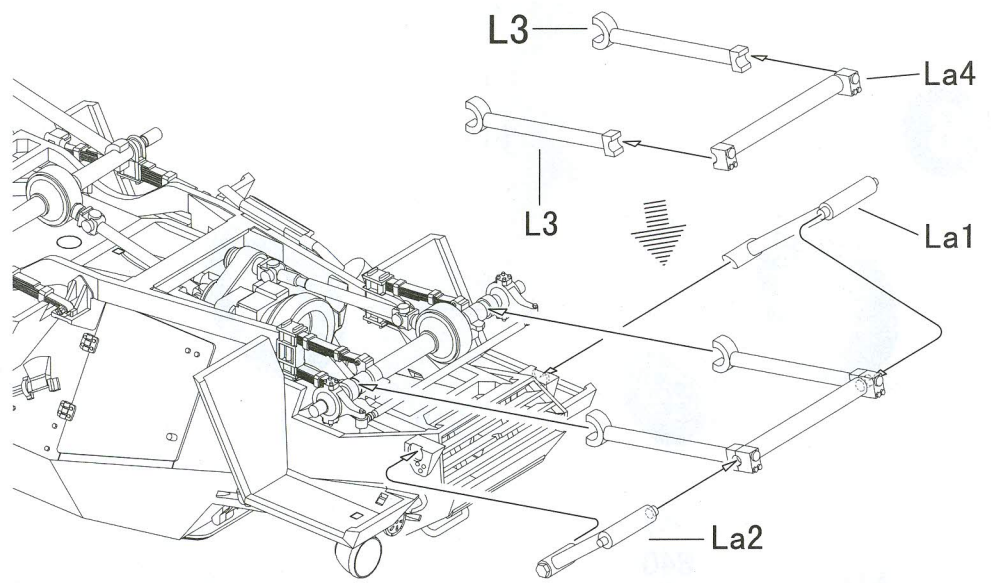
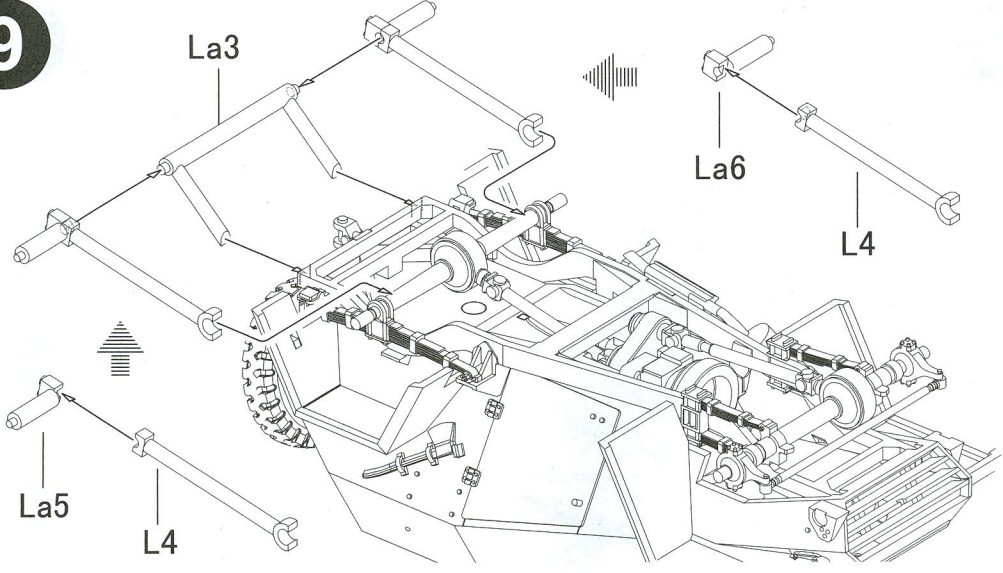

10

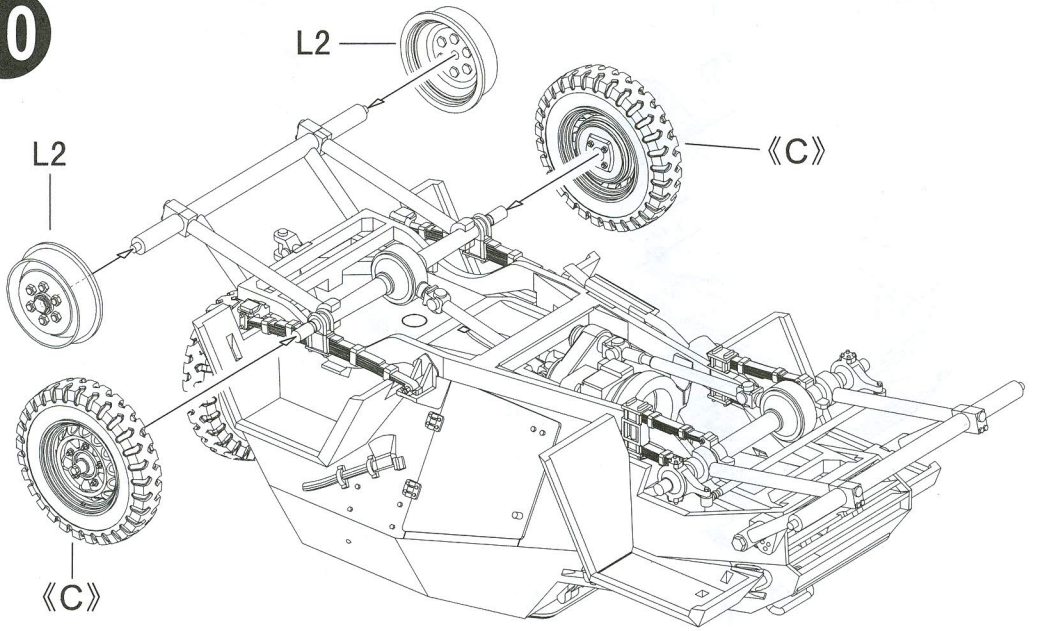

11

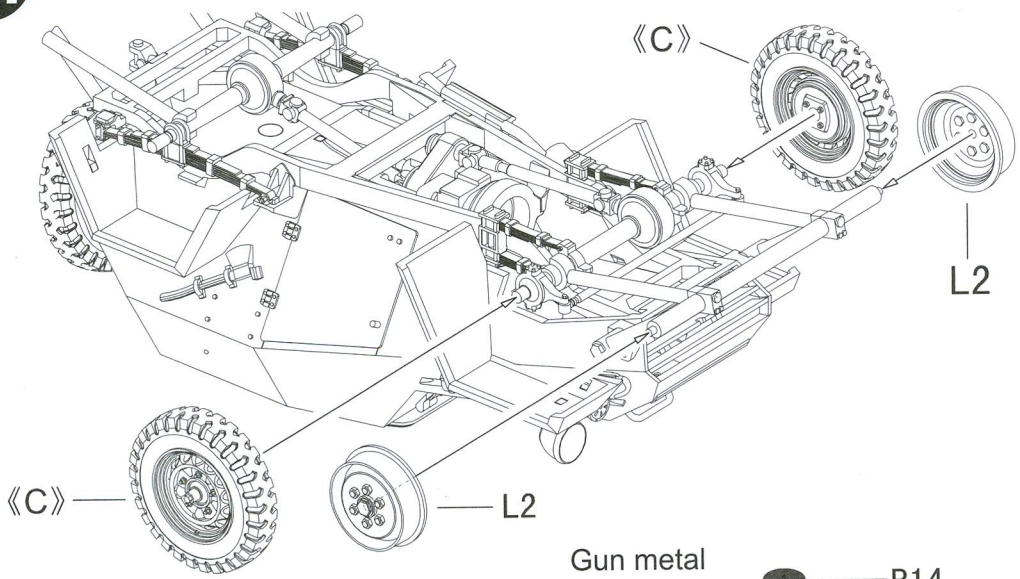

12

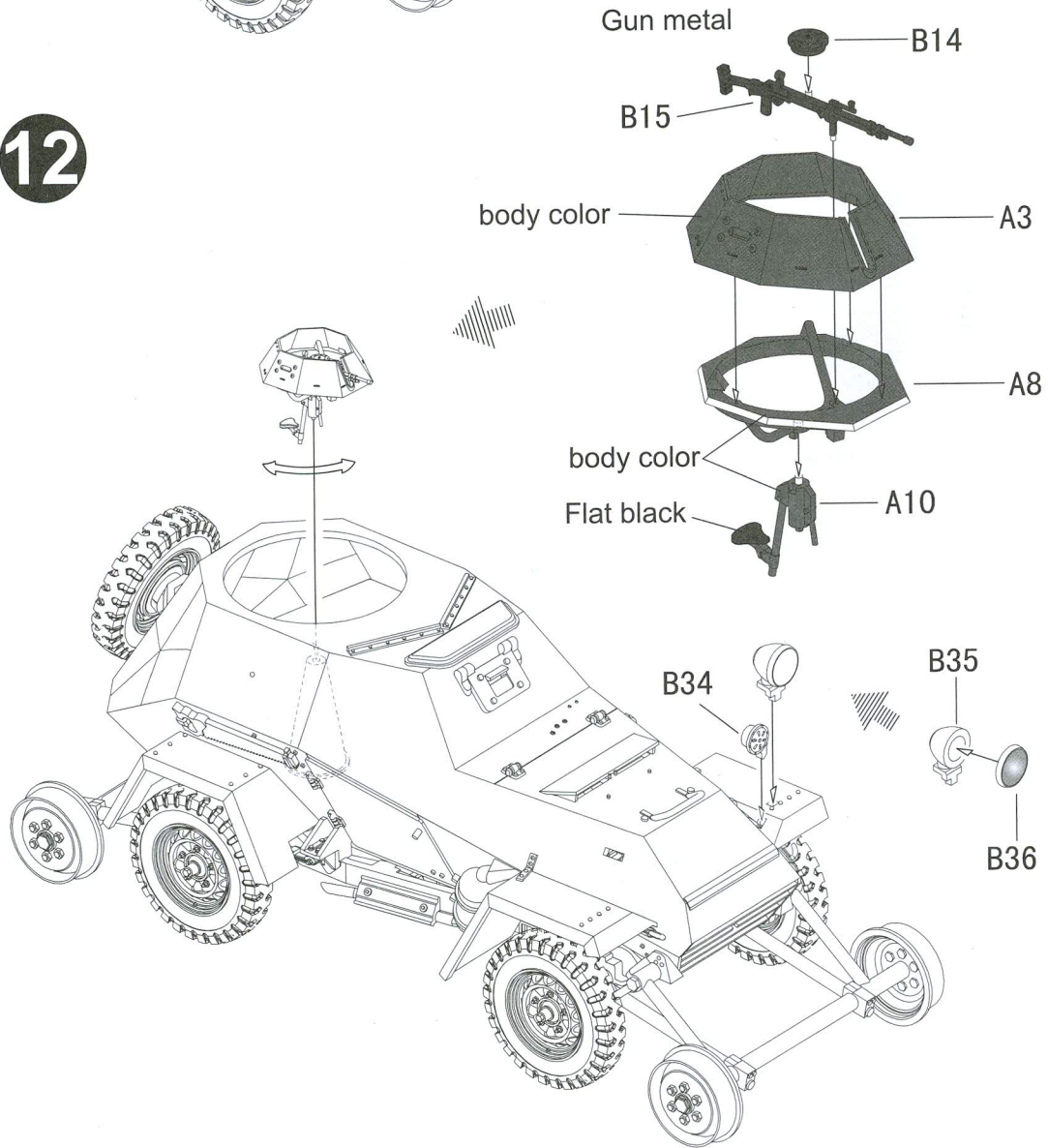

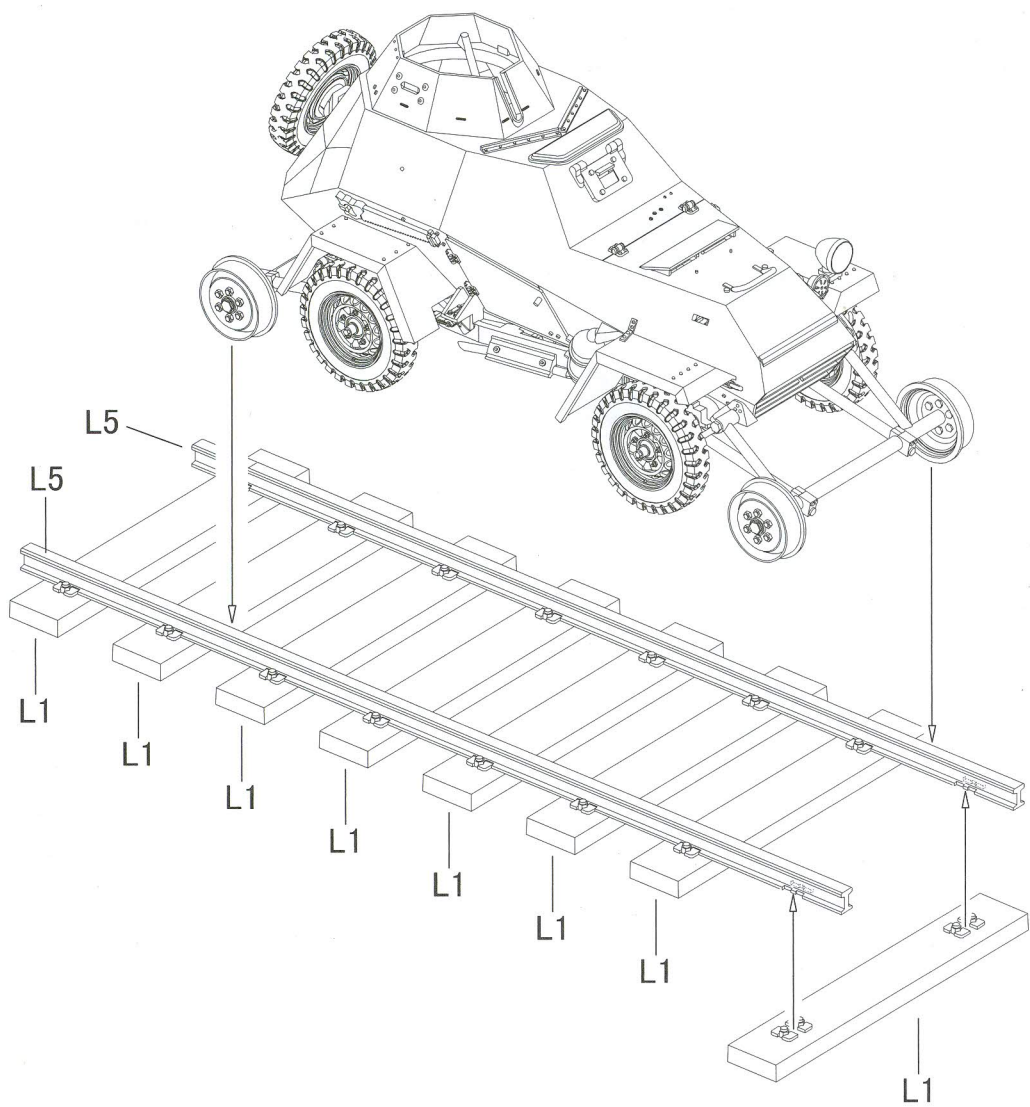

Decals & Painting:

水貼及塗裝指示:

Camouflage Scheme: Overall Russian green or Olive drab

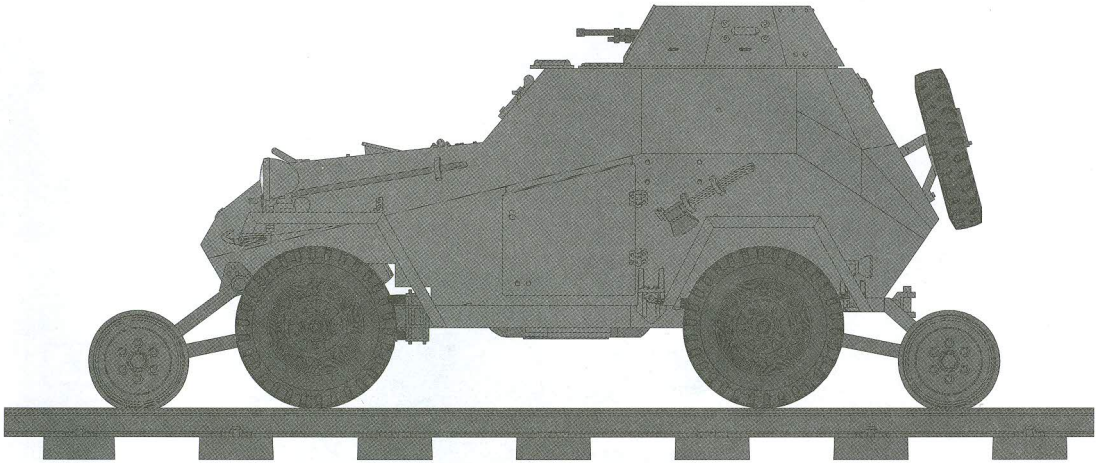
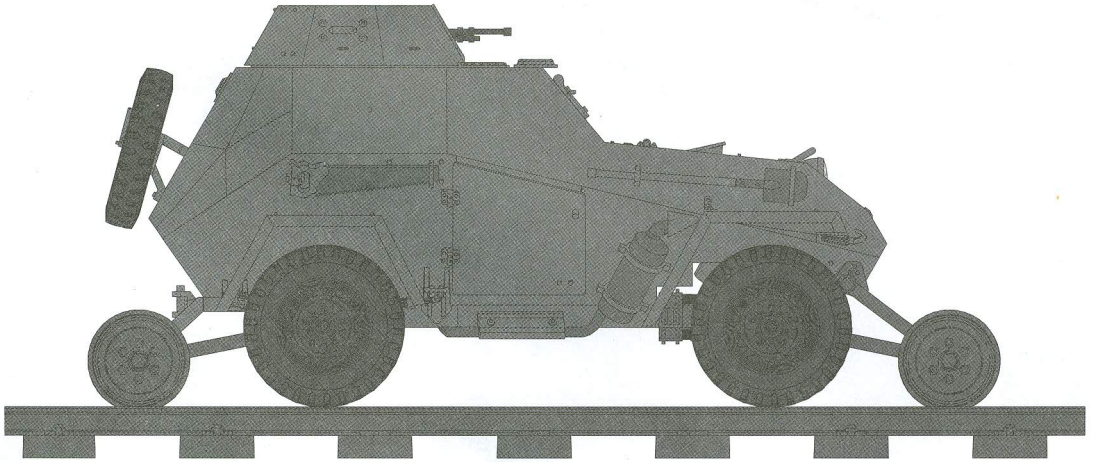
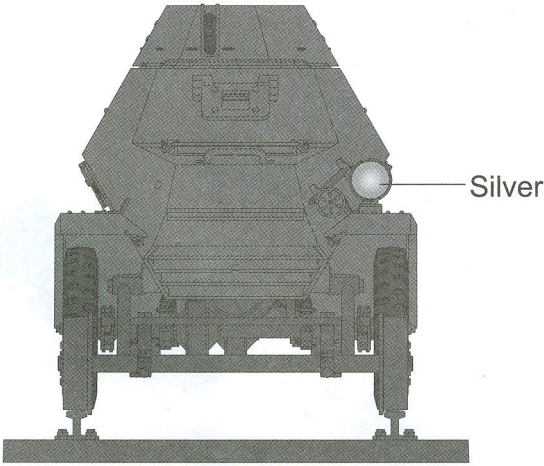

Warning! Not suitable for children under 3 years due to small parts.
警告! 內含小零件, 勿讓3歲及以下兒童接觸。

Standard: GB 6675-2003
執行標準: GB 5296.5-2006
QB/T 2862-2007

Main Material: PS Plastic
主要材質: PS塑膠

Vision Models
3F-8, No 59, Sec-1, Jhonghua Road,
Taipei city, Taiwan

copyright©2010 *All right reserved by Vision Models