

US PIPER CUB L-4 (O-59) 'GRASSHOPPER' 1/35 SCALE 美國小笛手L-4(O-59) '草蜢'式聯絡/觀測機

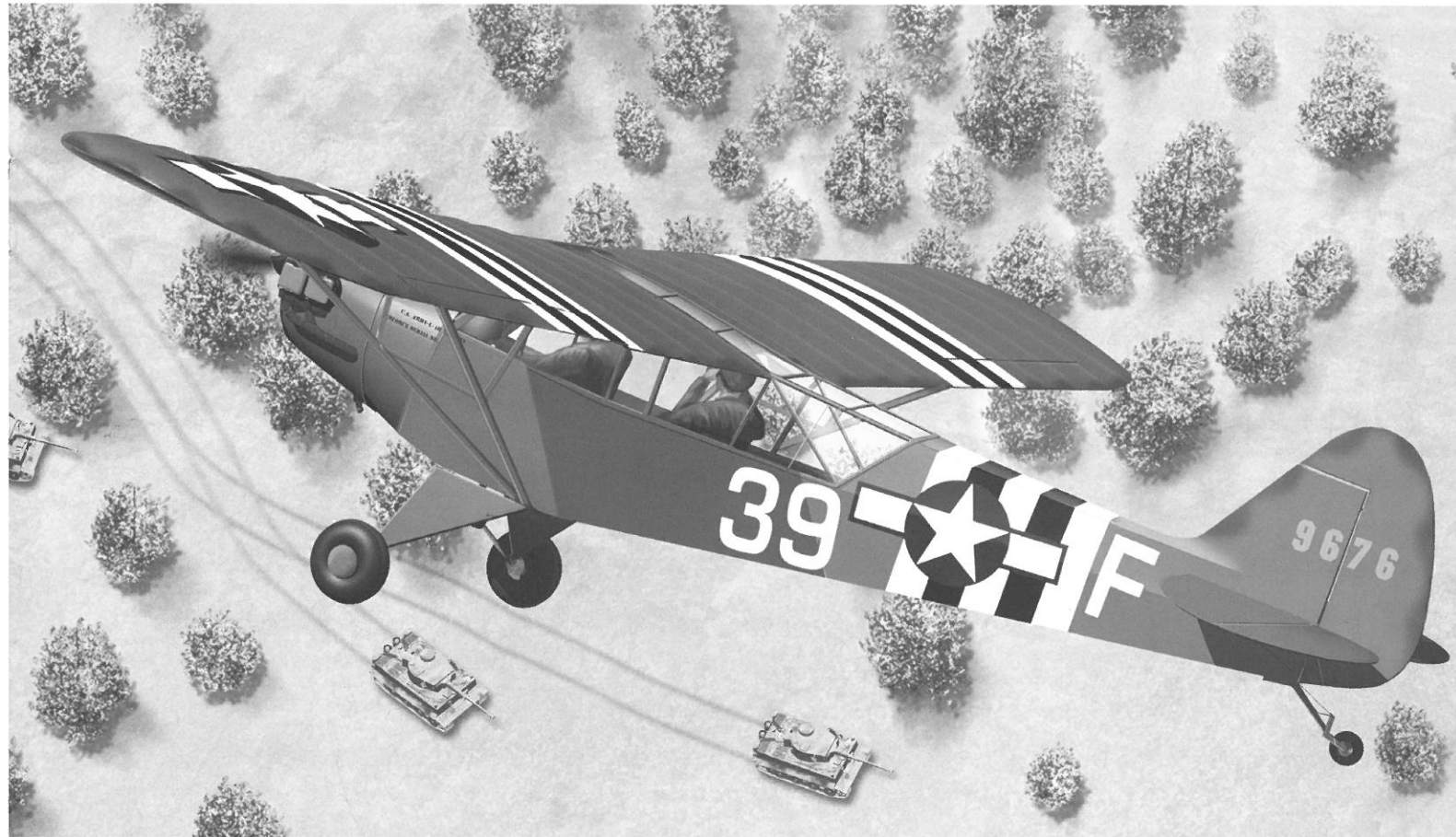

The Piper aircraft company built over 5,500 O-59 variants for the USAAF during WWII. These were known by the military designation L-4, and nicknamed the Grasshopper. This light aircraft was a single-engined high-wing monoplane with a fixed undercarriage. It was equipped a 65HP Continental O-170-3 flat-four air cooled engine and was constructed of steel & aluminium covered by doped fabric. The Piper L-4 was a very successful aircraft and was used in the courier, reconnaissance, observation, pilot training and ambulance roles. The L-4H was an improved version of the L-4B. Some operational aircraft were armed with rocket launchers or bomb points to allow them to attack targets of opportunity under favourable conditions. The American also provided some aircraft to the RAF and other Allied air forces during WWII. The L-4 went on to serve in the Korean War, being finally replaced by the Cessna O-1 Bird Dog in the early 1950s.

二次大戰期間美軍方於各主要戰場使用多款不同公司生產之小型飛機作為聯絡/觀測之用。小笛手公司為應軍方要求生產了一系列L4不同型號之'草蜢'式聯絡/觀測機，L-4型被美軍方編號為(O-59)，系列中有A/B/C/D/F/E/G/H及J型。L-4為高翼式設計，雖然只由一個四汽缸65匹馬力之小發動機推動，但由於全身由鋁及鋼管組合外蒙纖維布而成，所以全機載滿只重半公噸，約只為一輛普通之吉甫車車重而矣。L-4除可作聯絡及空中觀測使用外，還可作為訓練、搬運傷兵甚至有被加裝火箭筒改為小型攻擊機使用。L-4H由L-4B型改良而成，除在戰場廣泛使用於各砲兵及前線作戰單位，而且部份此款飛機亦供應給其他各盟國使用。二次大戰後L-4一直被使用於韓戰直至後來(O-1)L-19型出現為其替代。

ILLUSTRATION 圖示說明：

CORRECT METHOD FOR APPLYING DECALS 正確使用水貼紙方法：

1. 將需要貼上水貼之部位表面擦乾淨。
2. 將所需之貼紙剪下泡在清水裏約15至20秒。
3. 將濕透之貼紙取出置放於正確之位置旁。
4. 用棉花棒輕推貼紙表面使其從底紙滑出至模型表面之正確位置。
5. 待其自然乾透後即完成。

1. Clean model parts surface with wet cloth.
2. Cut out the decal parts and dip them in cold water for 15 ~20 seconds.
3. Place it on correct position of the model kit.
4. Slide off the decal from the base paper on to the model kit surface with a cotton stick.
5. When decal get dry then complete.

ICON INSTRUCTION 圖標說明：



COLOR SUGGESTION 塗裝指引：

Colour	Colour	Gunze Sangyo Hobby Color	Gunze Sangyo Hobby Color	Humbrol	Tamiya
Silver	銀	H-8	C-8	11	X-11
Flat white	消光白	H-11	C-62	34	XF-2
Olive Drab	橄欖褐	H-78	C-38	66	XF-62
Dark Green	深綠	H-36	C-17	30	XF-61
Tire Black	輪胎黑	H-77	C-137	85	XF-1
Steel	黑鐵	H-18	C-28	53	XF-16+XF-1
Neutral Gray	中灰	H-53	C-13	/	XF-53
Burnt Iron	燒鐵色	H-76	C-61	201	XF-56
Wood Brown	木啡色	H-37	C-43	186	XF-10
Flat Black	消黑色	H-12	C-33	33	XF-1
Flat Yellow	消黃色	H-4	C-4	99	XF-3
Khaki	啡色	H-81	C-55	26	XF-49
Flesh	肌肉色	H-44	C-112	61	XF-15
Red Brown	啡紅色	H-47	C-41	100	XF-64
Flat Earth	土色	H-72	C-133	29	XF-52

PARTS LIST 零件展示表：



Bronco Models

Copyright©2006

Made in China
中國製造

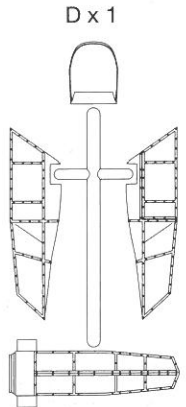
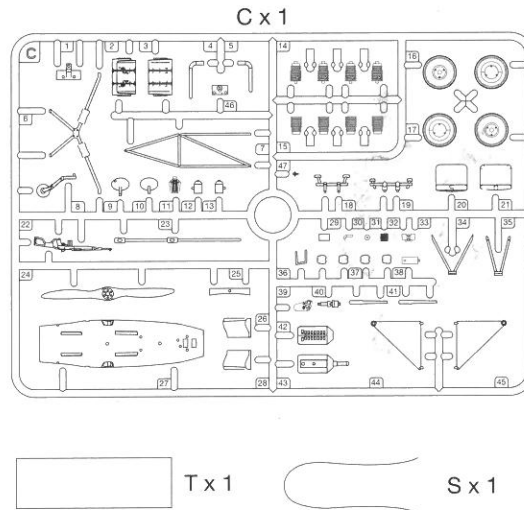
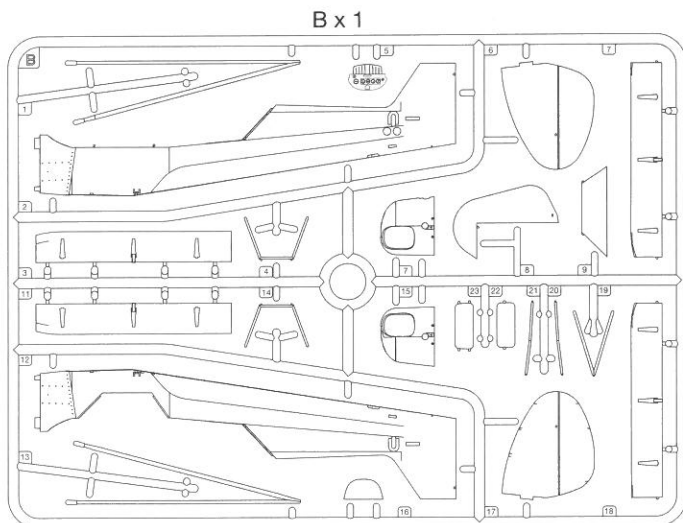
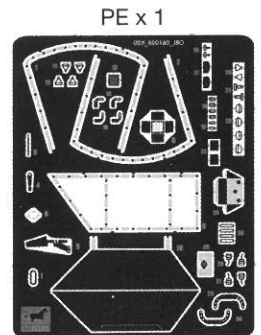
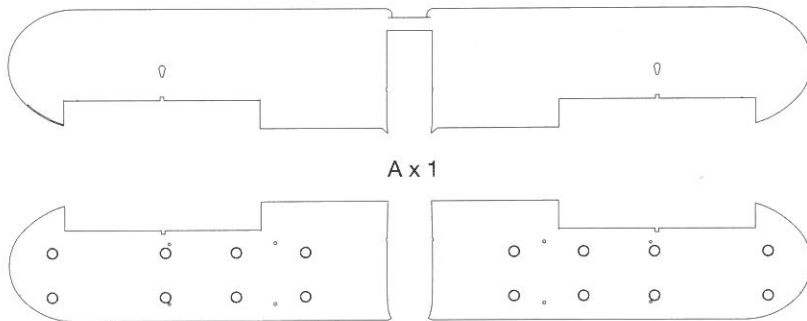

READ BEFORE ASSEMBLING

- Carefully Study instruction before assembling. 組裝前請閱讀清楚製作指引。
- Keep plastic model glue and tools away from children. 膠水、油漆及工具勿讓小孩接觸。
- Do not use cement or paint near open flame or sparks. 膠水及油漆勿接觸火種。
- Do not work in closed room. 勿在密封地方製作模型。

1 *Cockpit assemble 駕駛艙組裝

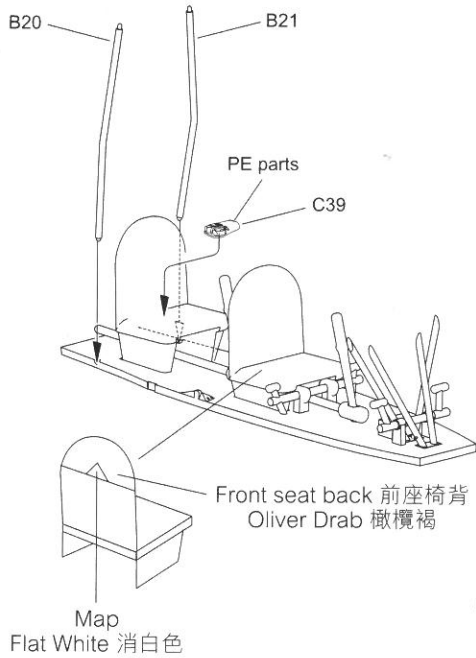
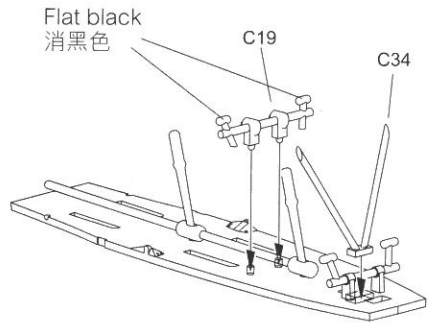
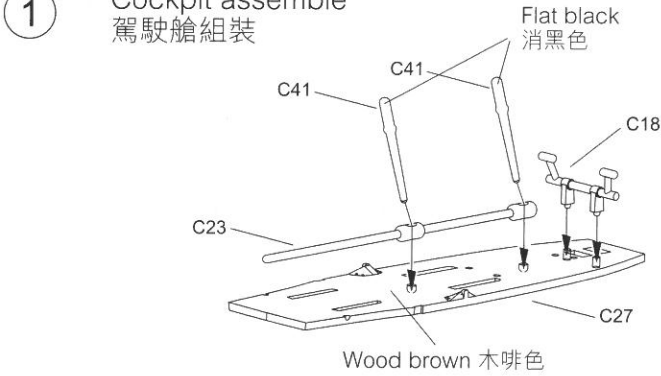

Rear twin seat (for general purpose)
後部雙座座椅 (一般用途)

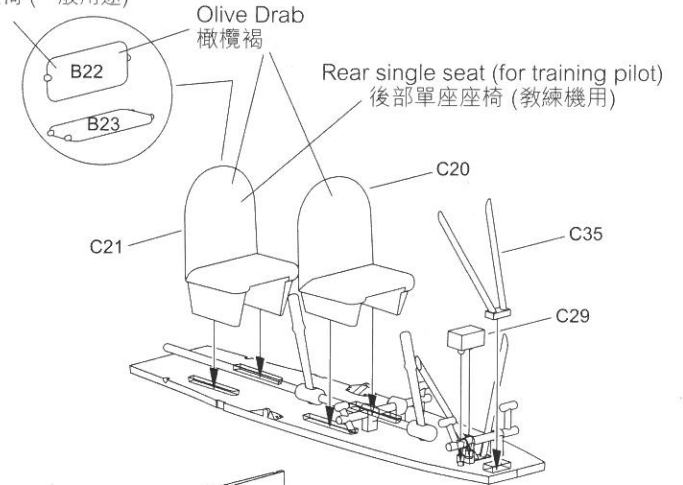

2 Left side Fuselage 機體左側

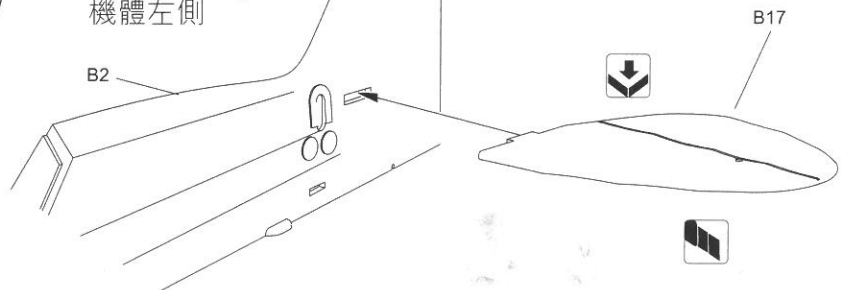

3 Entrance door assemble 機艙門組裝

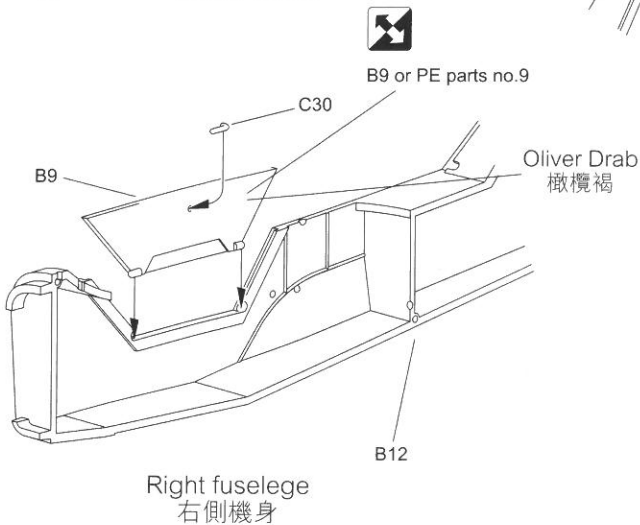

4 Tailspan assemble 尾翼安裝

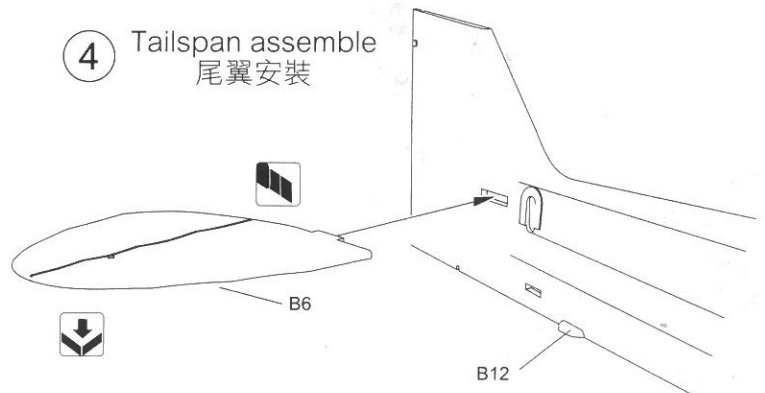

5 Fuselage assemble
機體安裝

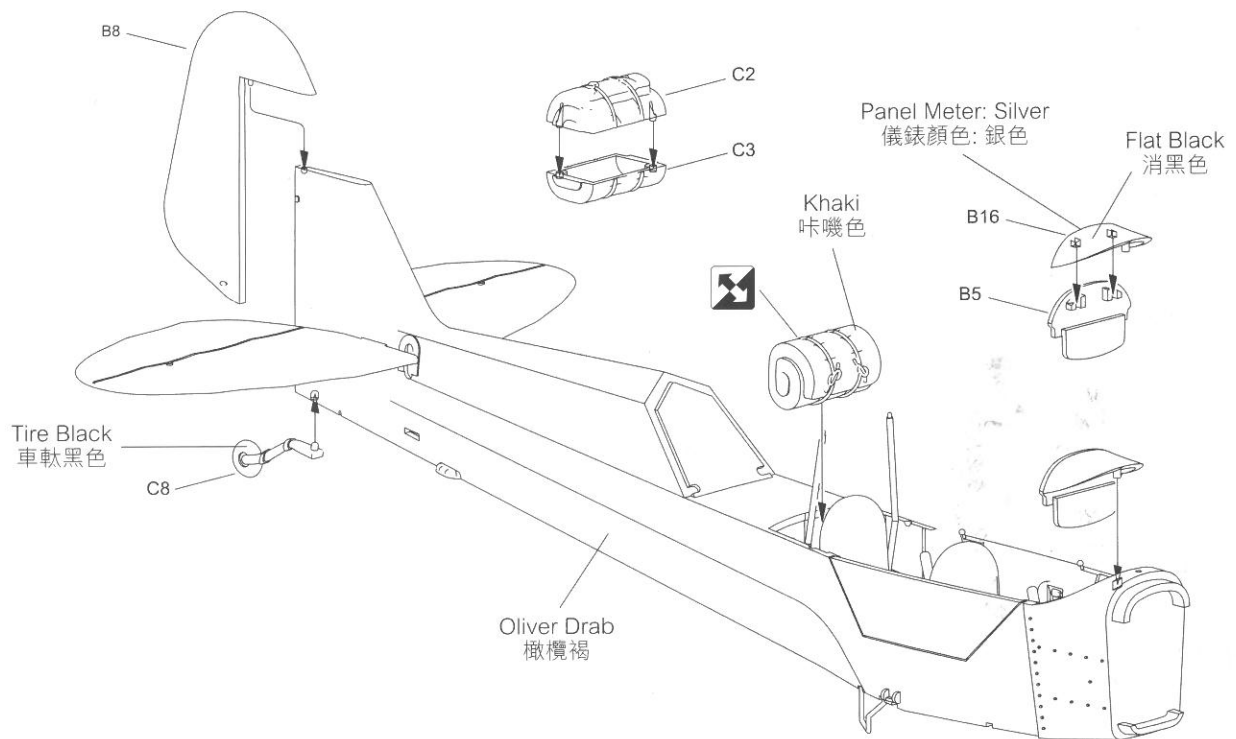
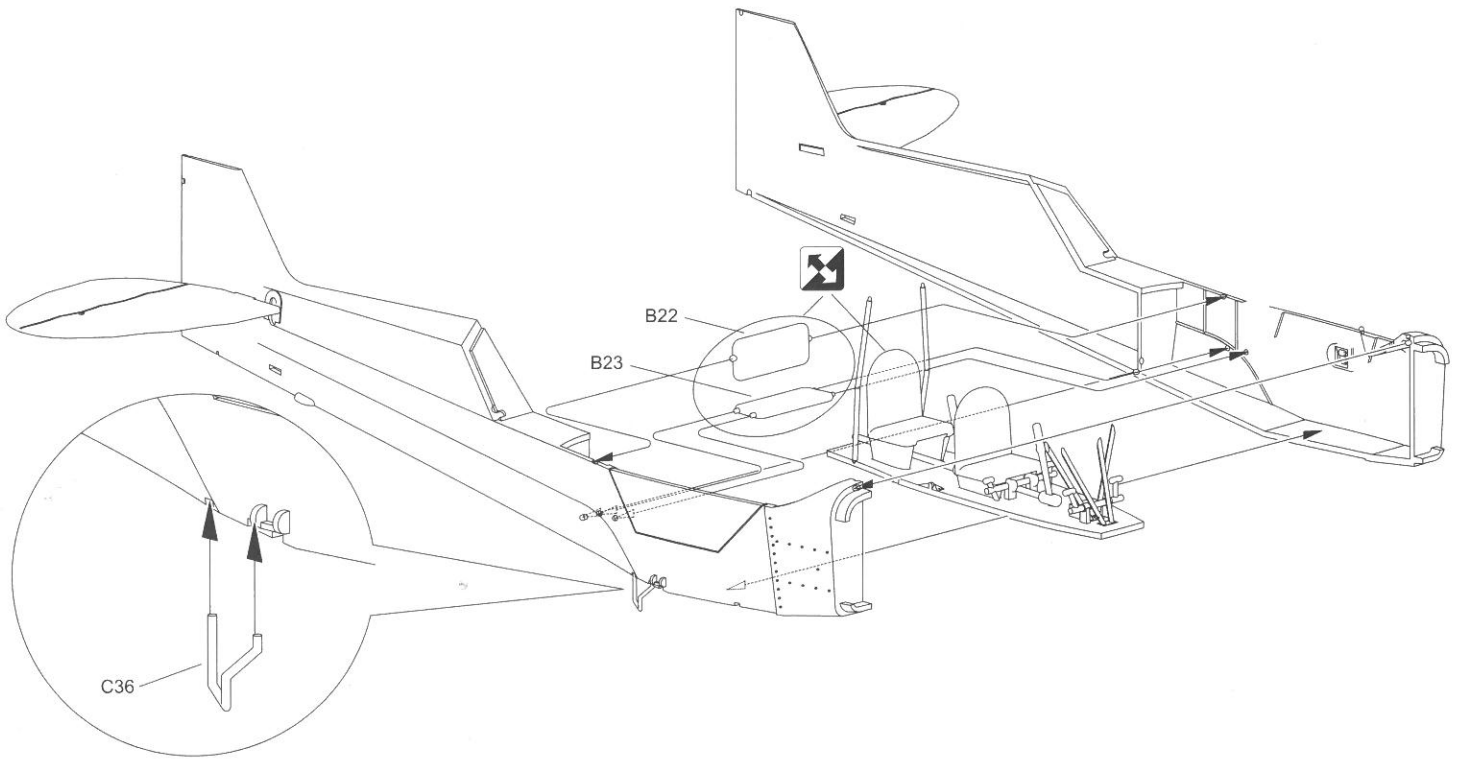
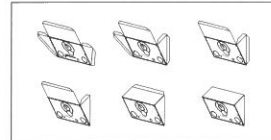
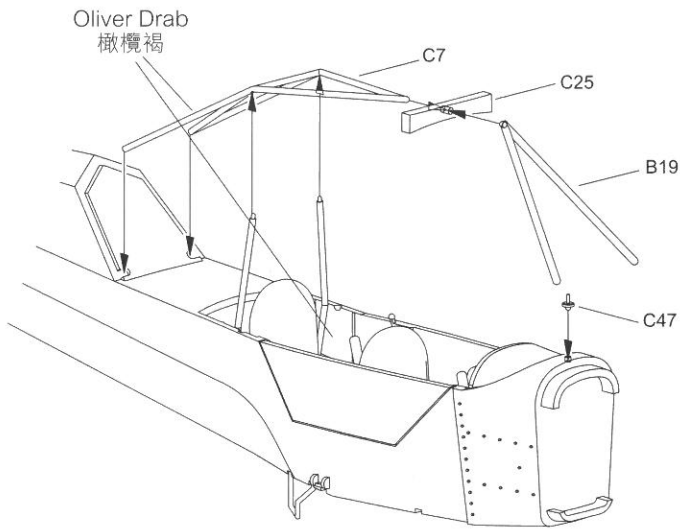
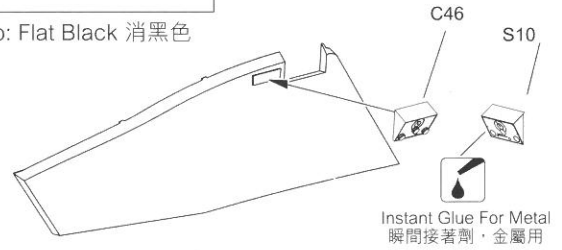

ILLUSTRATION 組裝說明：



PE parts no. #24 assemble guide
蝕刻零件#24組合

Radio: Flat Black 消黑色



Instant Glue For Metal
瞬間接著劑·金屬用

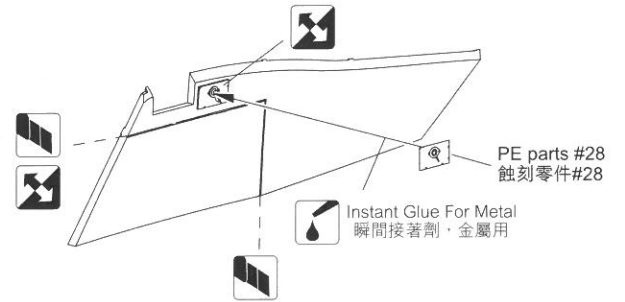

PE parts #28
蝕刻零件#28

Instant Glue For Metal
瞬間接著劑·金屬用

Caution: Cut the wing nuts from the sprue D runner & glue its onto the windshield side or replace by the PE parts no.1 & 2.
注意：擋風玻璃窗框之鉚釘可從D版流道切下使用或使用蝕刻零件no.1&2.

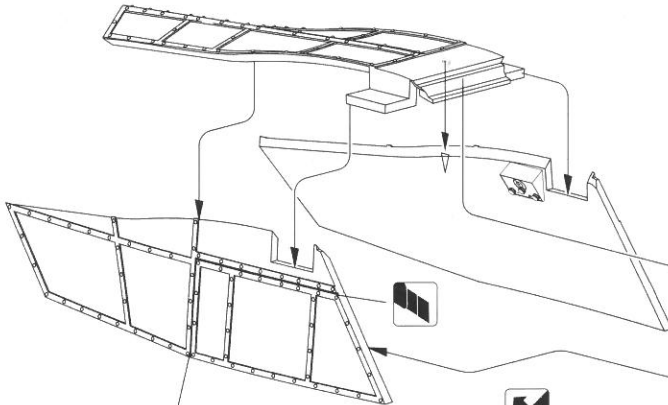

Please cut and replace by the PE parts#9 + T1 if choose the window when open position.
如選擇打開狀態，請依指示自行切出及用蝕刻零件#9及透明膠片代替

PE parts no. 1&2
可選擇蝕刻零件No. 1&2

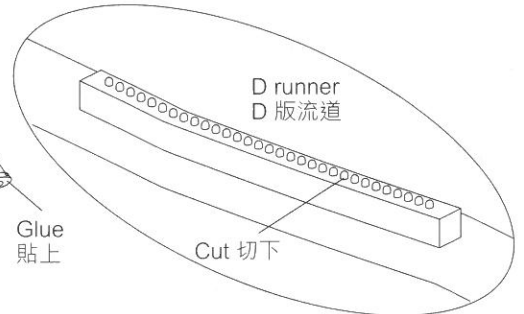

Glue 貼上

Cut 切下

Caution: Please cut the T1 Transparent plastic sheet to the window actual size.
請將T1透明膠片裁剪成與蝕刻零件#9相同大小尺寸備用。

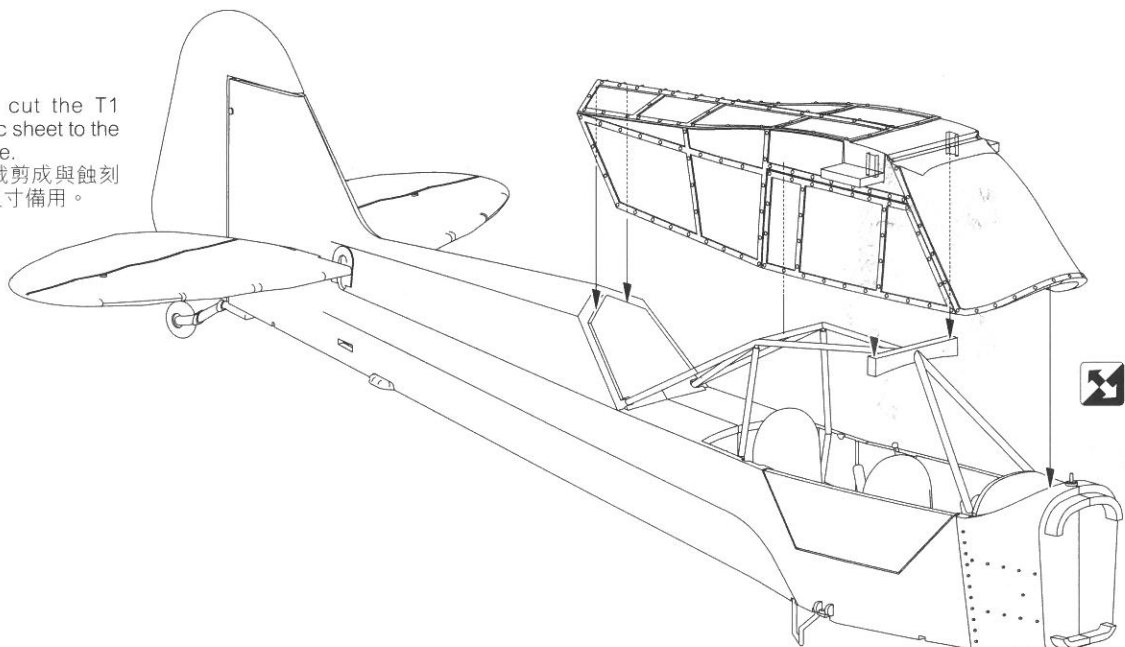
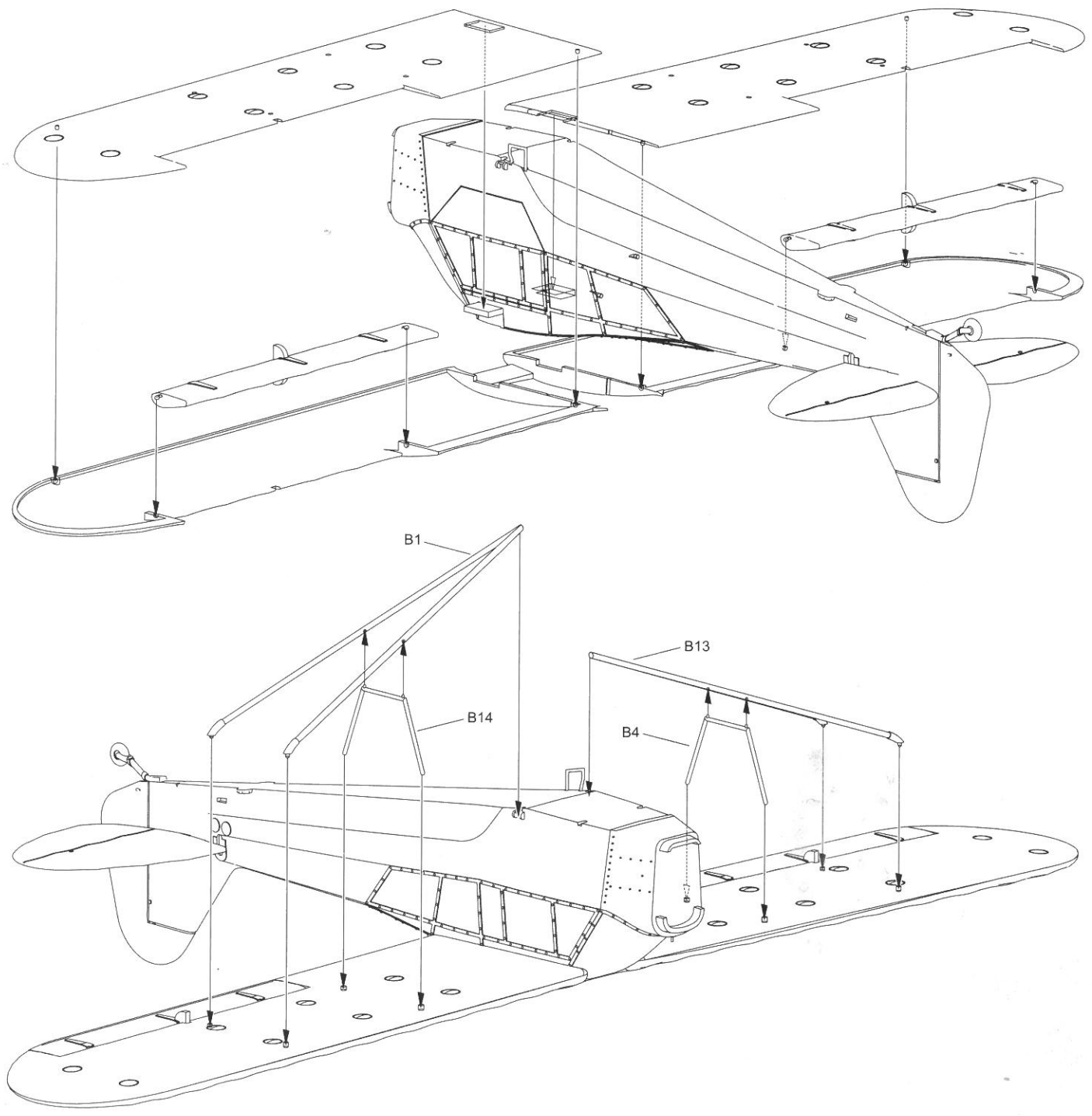
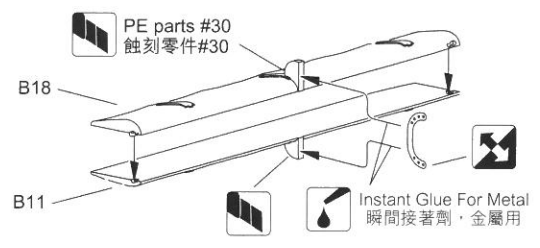
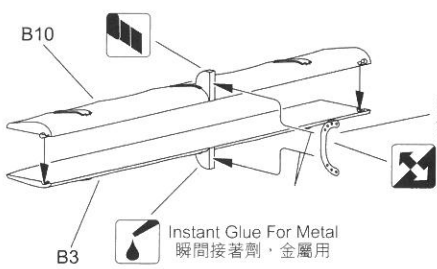

ILLUSTRATION 組裝說明：

Caution: remove & replace by the PE parts #30 if necessary.
 注意：如有需要請切除所示部份及用蝕刻零件no. #30代替



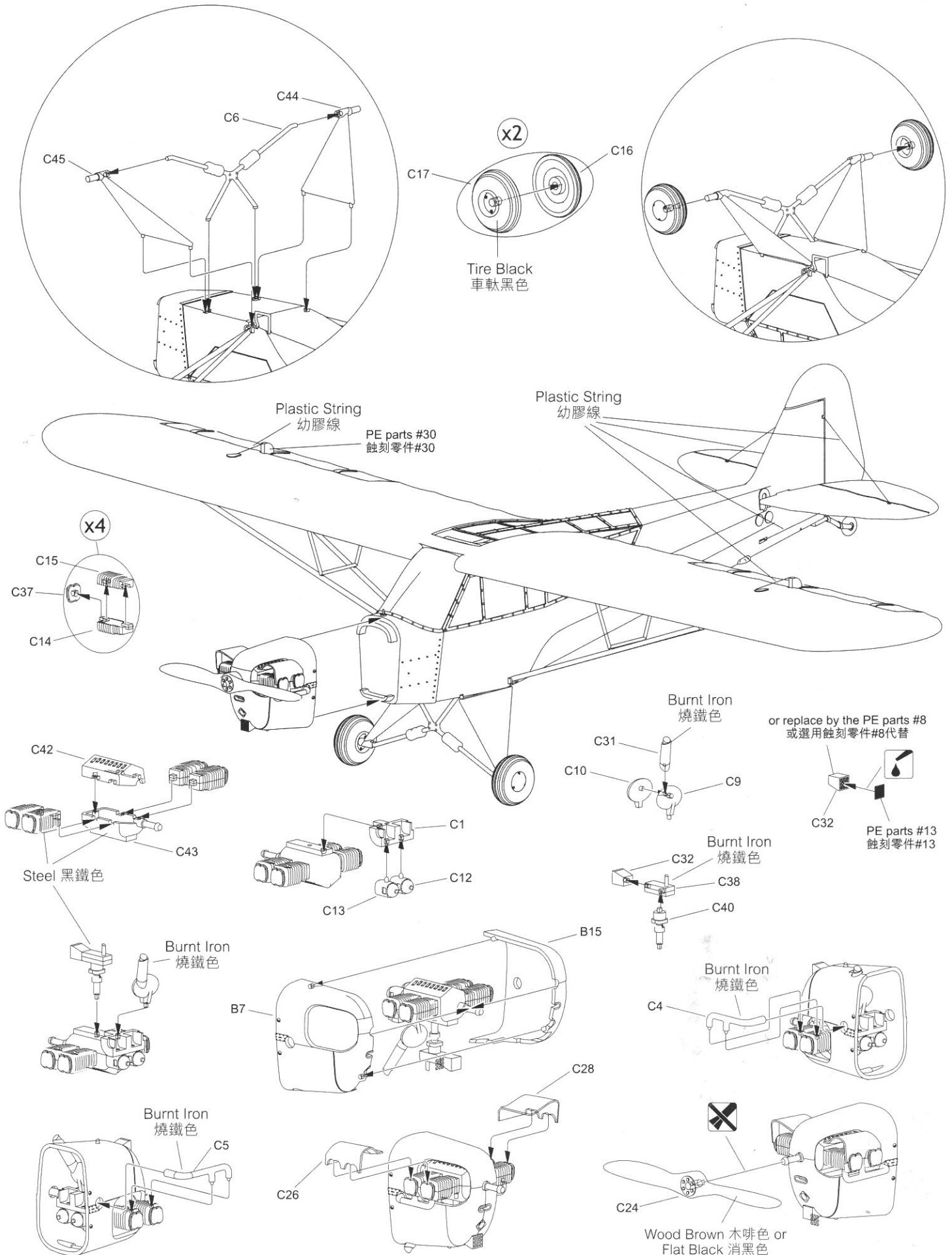
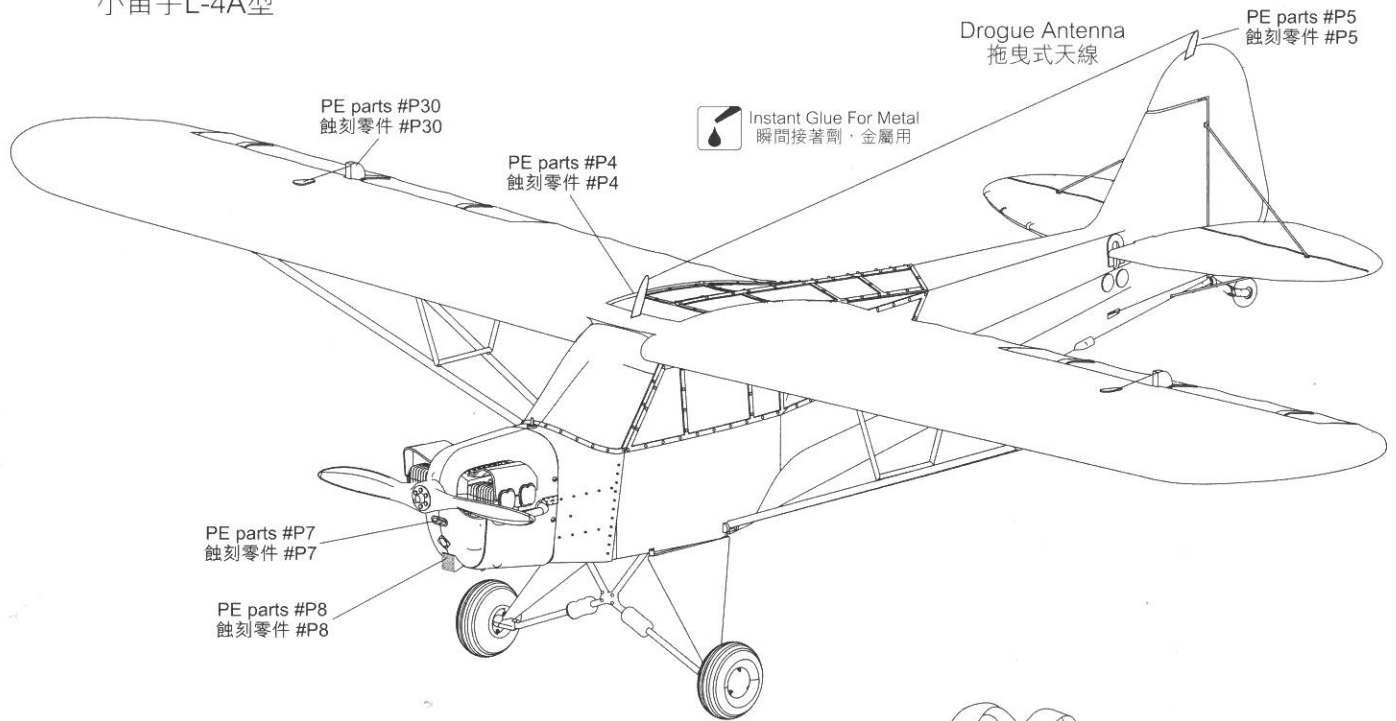

ILLUSTRATION 組裝說明：

Piper Cub L-4A
小笛手L-4A型



Pilot seat belt

Type 1,2 are common used for US aircraft during WWII
第1、2兩款機師安全帶均有使用於第二戰美國軍機

Seat Belt not included, please
use a piece of paper to make
本套件不包含安全帶，請用適
合之紙張製作

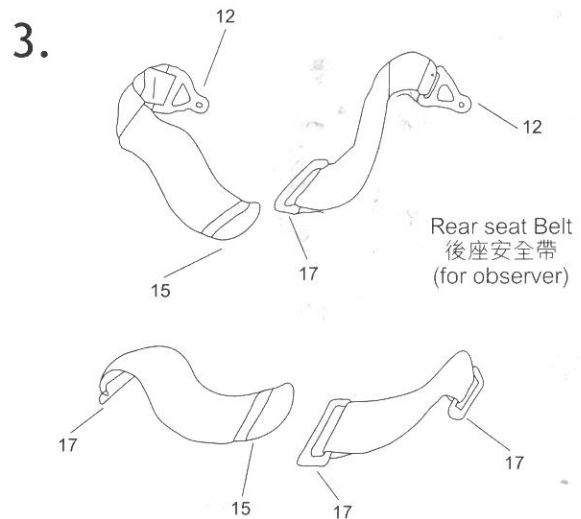
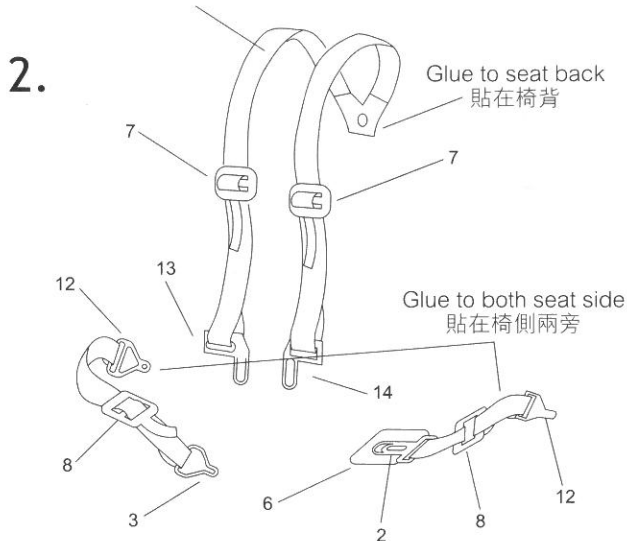
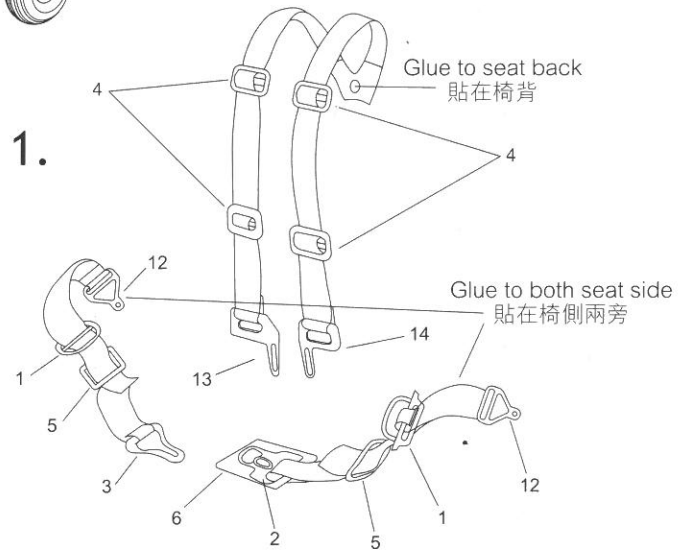



Piper Cub L4A, "Operation TORCH" North Africa, Nov, 1942.
1942年11月使用於北非登陸作戰之'火炬行動'連絡機

Colour : Cowling(Yellow),
Overall fuselage (Olive Drab)



Piper Cub L-4J, "Artillery Headquarter of US 3rd Army, Italy, 1943.
1943年冬於意大利作戰用之美國第三軍砲兵指揮單位連絡機

Colour : Overall fuselage (Olive Drab)



Piper Cub L-4H, US Army V Corps Field Artillery, Normandy, 6th June, 1943.
1944年6月6日使用於諾曼第登陸作戰之美軍第五砲兵隊之觀測機

Colour : Upper Surfaces (Olive Drab),
Splotches (Medium Green),
Under Surfaces (Neutral Gray)



Piper Cub L-4B, 91st Bomber Group, 8th USAAF Air Army, England, early 1945.
1944年初隸屬於英倫本土之美國陸軍第八航空軍屬下之91轟炸機群大隊連絡機

Colour : Overall (Silver)