

**CAUTION**

These resin-casted accessories and photo-etched parts can only be glued using cyanoacrylate glues. These glues are not without danger, so be careful when using them. Work in a well-ventilated area only and avoid inhaling the fumes for they can be harmful. Thoroughly wash your hands after use.

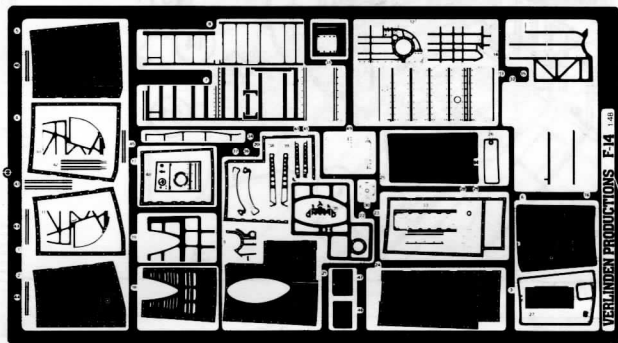

**RECOMMENDED KIT**

Hasegawa's F-14A Tomcat 1/48

**RECOMMENDED REFERENCE MATERIAL**

- F-14 A&B Tomcat  
Detail & Scale Vol 9 /Bert Kinzey  
Detail & Scale Publications
- F-14 Modern Fighting Aircraft  
Salamander's Aviation Fact File  
Salamander Books

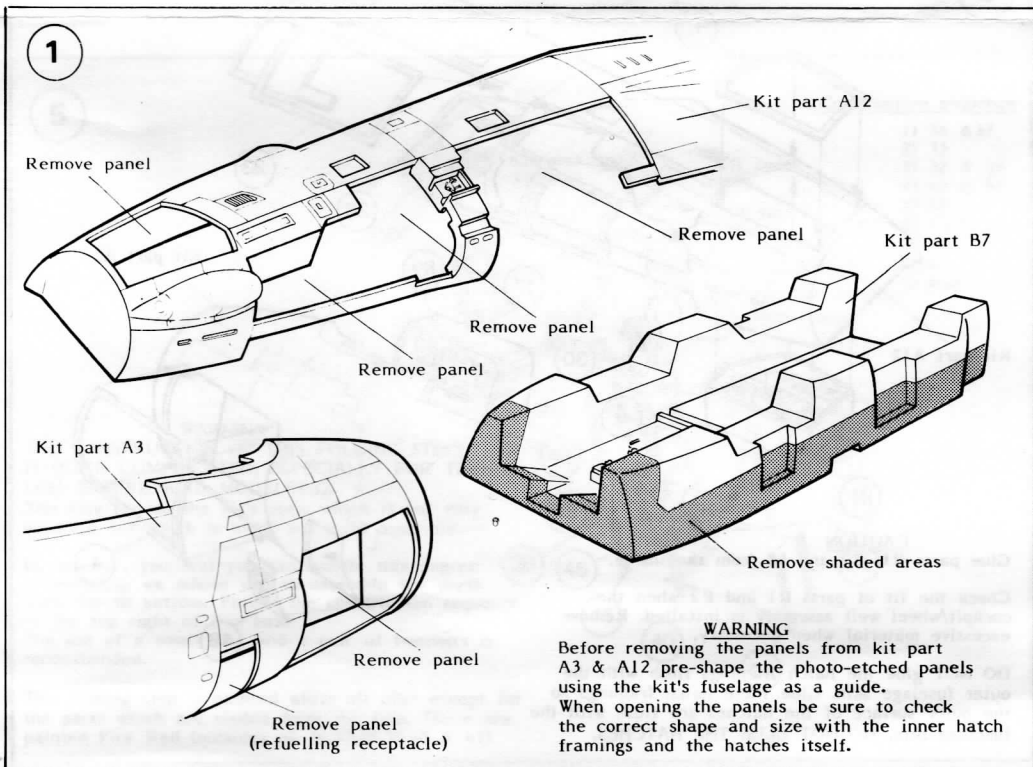
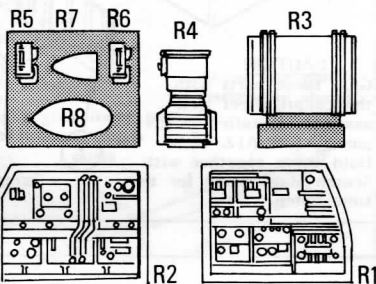

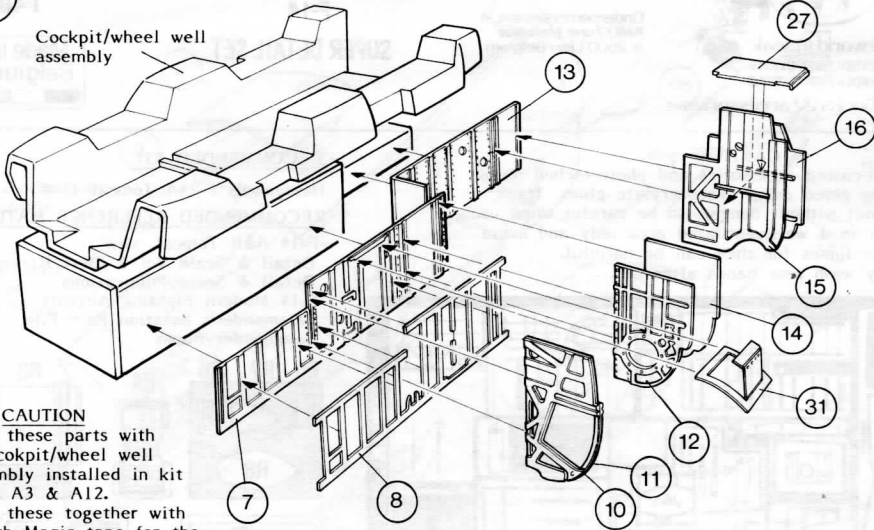
**2**Cockpit/wheel well  
assembly**CAUTION**

Glue these parts with the cockpit/wheel well assembly installed in kit parts A3 & A12. Hold these together with Scotch Magic tape for the time being.

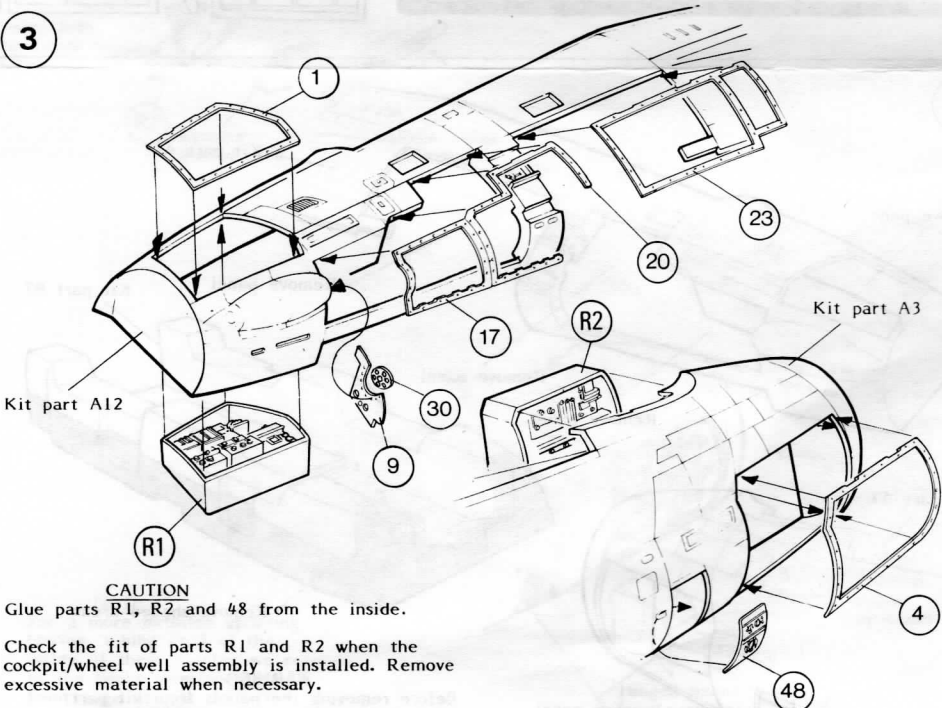
**3****CAUTION**

Glue parts R1, R2 and 48 from the inside.

Check the fit of parts R1 and R2 when the cockpit/wheel well assembly is installed. Remove excessive material when necessary.

DO NOT glue the hatch framings flush with the outer fuselage skin. Glue these hatch framings so the outer surface of the hatches are flush with the fuselage skin. DO NOT GLUE THE HATCHES.

4

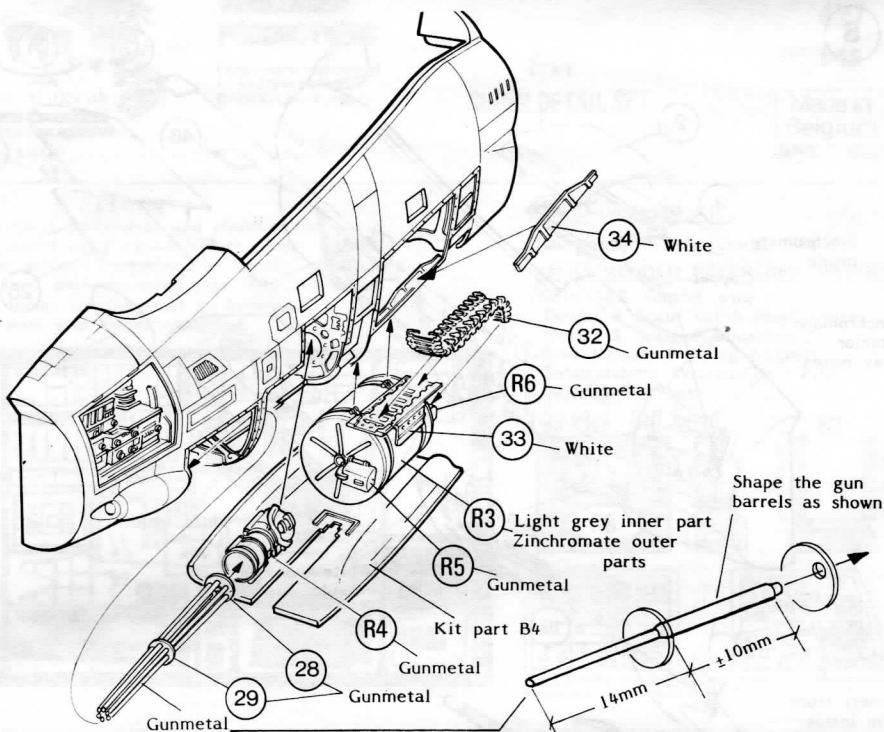

5

## Construction sequence

- 1) 36 & 37
- 2) 35
- 3) 38 & 39
- 4) 40 & 41
- 5) 42
- 6) 43
- 7) 44
- 8) 45
- 9) Rod

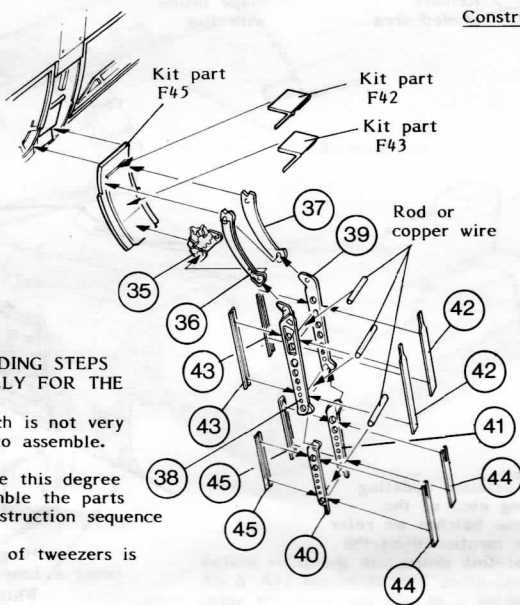

## WARNING

THE CONSTRUCTION OF THIS FOLDING STEPS IS QUITE COMPLICATED, ESPECIALLY FOR THE LESS EXPERIENCED MODELERS.

You may choose the kit's step, which is not very accurate but which is much easier to assemble.

If, however, you feel you can handle this degree of modeling we advise you to assemble the parts from top to bottom. Follow the construction sequence in the top right of this box.

The use of a small vise and a pair of tweezers is recommended.

This folding step is painted white all over except for the parts which are visible from the side. These are painted Fire Red (outsides of 36,37,38,39,40 & 41)

