

FRIED. KRUPP GRUSONWERK Magdeburg-Buckau.

Telegramm-Adresse: Grusonwerk, Magdeburg.

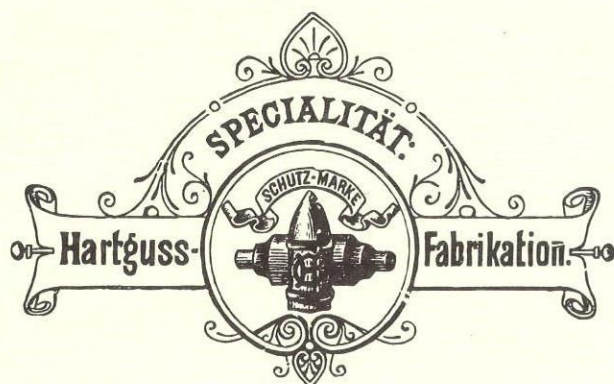

Fahrbare Panzerlaffete für eine 5,3 cm Schnellfeuer-Kanone

der Masstab 1 zu 35
sku: 35011

5,3sm GRUSON FAHRPANZER

The fahrpanzer is one of the most interesting pieces of military hardware to see widespread use. These “armoured carriages,” when viewed on their carriers, are often mistaken as a horse-drawn ancestor of the tank. They were, however, a creative innovation that not only allowed the construction of fortresses to be cheaper, but provided options for a more dynamic line of defense. When World War I broke out, the fahrpanzers saw service not just in fixed fortifications, but were transported to the trenches, where they were used to strengthen defensive lines and provide additional protection for crew-served weapons.

Often translated as “mobile armoured carriage,” the fahrpanzer was the brainchild of the Prussian officer Maximilian Schumann (1827-1899). Though several styles and derivatives of the original design exist, they all share the same basic characteristics: an armoured enclosure housing a small artillery piece and its crew that can rotate to provide a wide field of fire while being easily transportable on rails or horse-drawn carriages.

Following the American Civil War, fortresses underwent rapid development. As artillery became more destructive, it was clear that the older earthen fortifications would not be sufficient in future wars. Fortress designers took cues from naval architects and outfitted fortifications with armoured turrets housing large artillery. These emplacements were expensive, and needed to be defended from attack by smaller guns and firing locations.

Schumann, one of the leading experts in fortifications in the late 1870s and 1880s, was interested in the practicality of using small-caliber, rifled guns, and he envisioned installing them in small, mobile armoured turrets.

On Nov. 12, 1885, he patented his first design for the fahrpanzer in Germany. The patent featured a cylindrical armoured body with a small vestibule and a dome that rotated on top that had an aperture for the artillery piece, which rotated on a central pin inside the body. It was transportable on a specially fitted carriage that was drawn by a single horse.

In production, the fahrpanzers mounted several types of guns, including 37mm, 53mm and 57mm variants. Rails on the bottom were matched to the narrow-gauge railways installed in fortresses, allowing the fahrpanzers to be rolled into position, and even to fire, then “disappear” on the rails, either re-emerging after reloading or traveling to a new firing position.

More than 300 armoured carriages were built by the 1890s, mostly in Germany, but other countries used them as well, including Belgium, Bulgaria, Denmark, Romania, Switzerland and Chile.

During World War I, fahrpanzers were delivered to the front lines, and they provided stout defensive works in the trenches that layed down heavy fire and were very hard to hit with artillery, while being essentially impervious to small arms. The Allies, when they encountered them at Ypres in July 1917, termed them “pillboxes.”

The fahrpanzers were superseded by small armoured machine gun posts, and while a similar armoured machine gun pillbox was used by the Germans in World War II, the surviving fahrpanzers ended their service lives in minor uses – like on armoured trains – or as novelty trophies.

Text by Stanislav Kirilets, images from the author's personal archive.



Important Notes

- Read the instructions carefully before starting the assembly.
- Use glue intended for plastic models.
- Choking hazard. Keep small parts and plastic bags away from children.
- Always wear protective eyewear when cutting and a protective mask when painting, glueing and sanding.
- Use paints designed and suitable for plastic model kitsets.

Symbols Reference			
	No Glue		Apply Decal
	Other Side		Option
	Cut/Remove		Drill

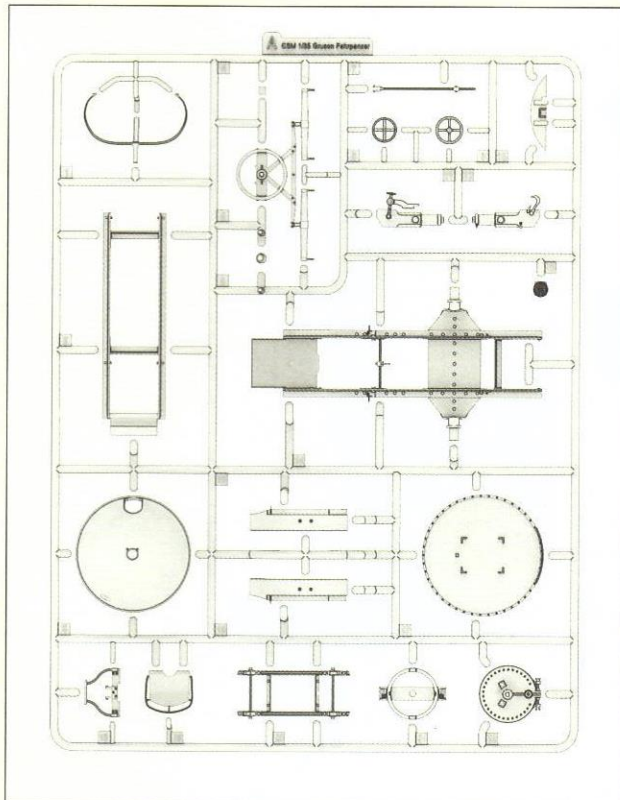

Fig. 1. Runner A

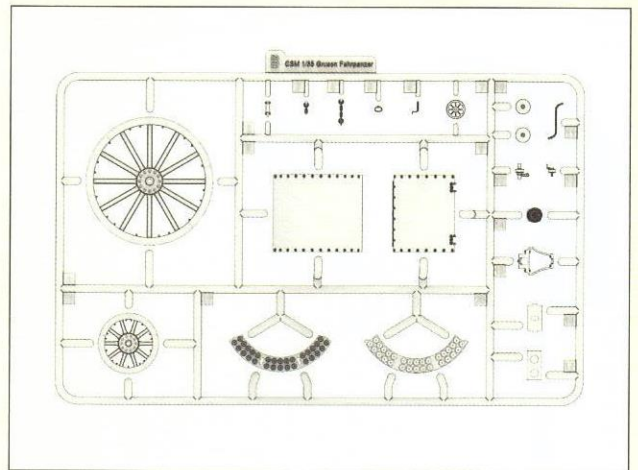

Fig. 2. Runner B, x2

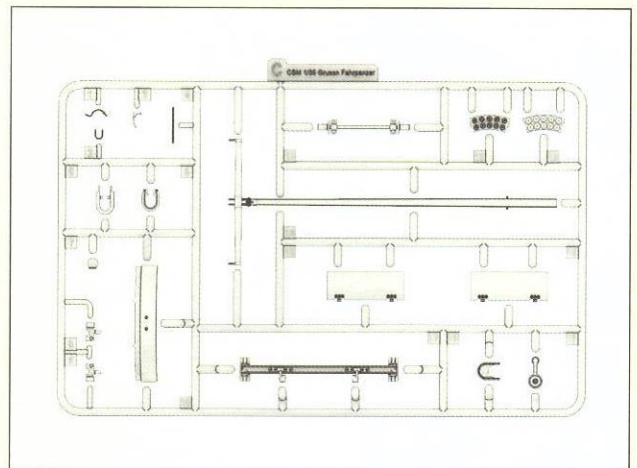
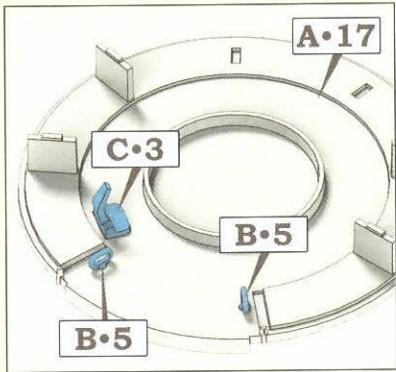

Fig. 3. Runner C

Colour numbers

1 Brass	5 Black	9 Ochre	13 Dark Ochre
2 German field-grey	6 White	10 Brown	
3 Copper	7 Leather	11 Green	
4 Gun metal	8 Steel	12 Wood	



Step 1. Assembling the turret base

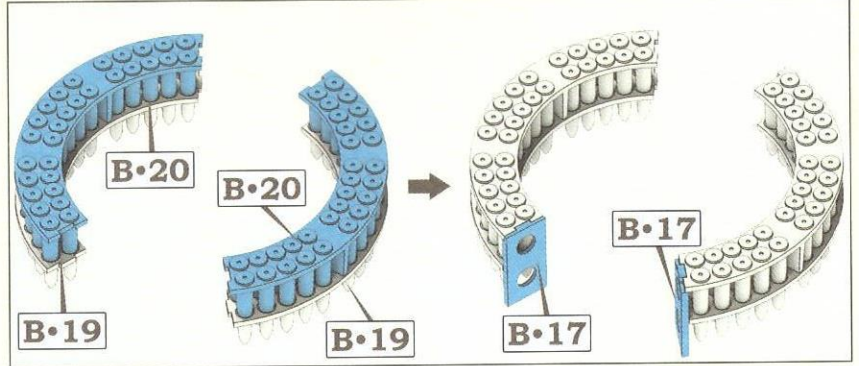

Step 2. Assembling the ammunition boxes

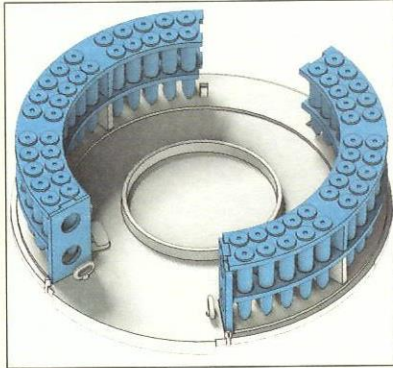

Step 3. Installing the ammunition boxes

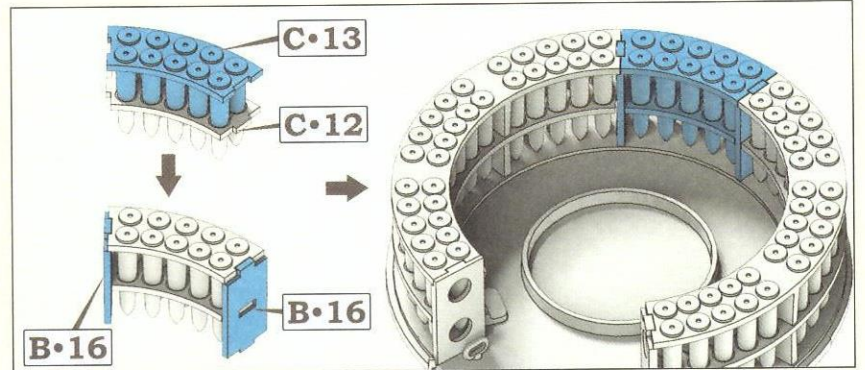

Step 4. Assembling and installing the last ammunition box

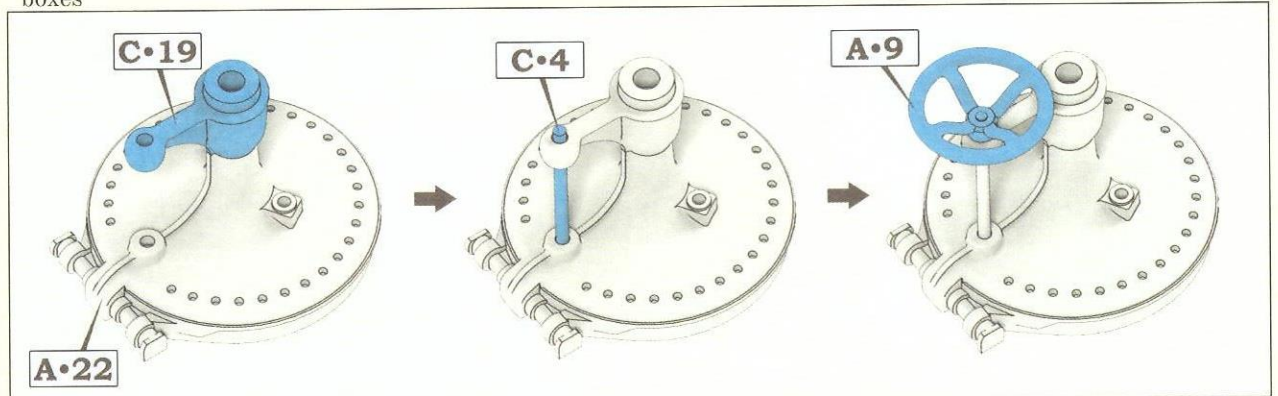

Step 5. Assembling the turning base of the gun

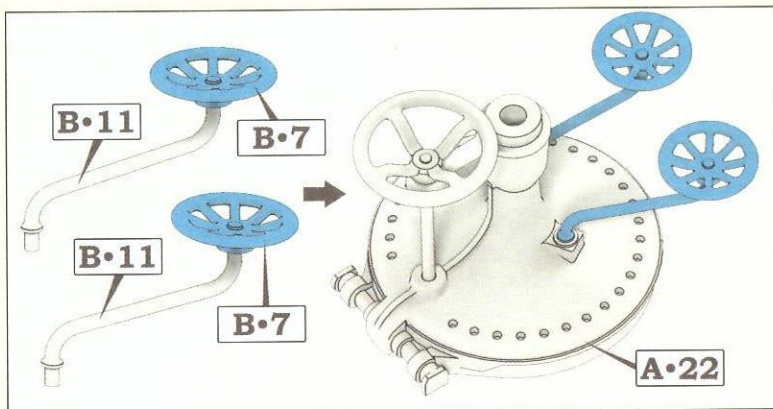

Step 6. Assembling the seats for the gun

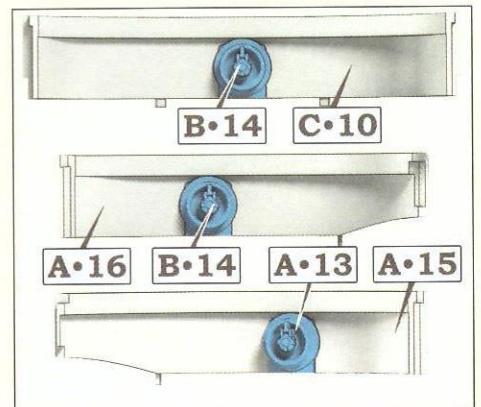

Step 7. Installing the rollers

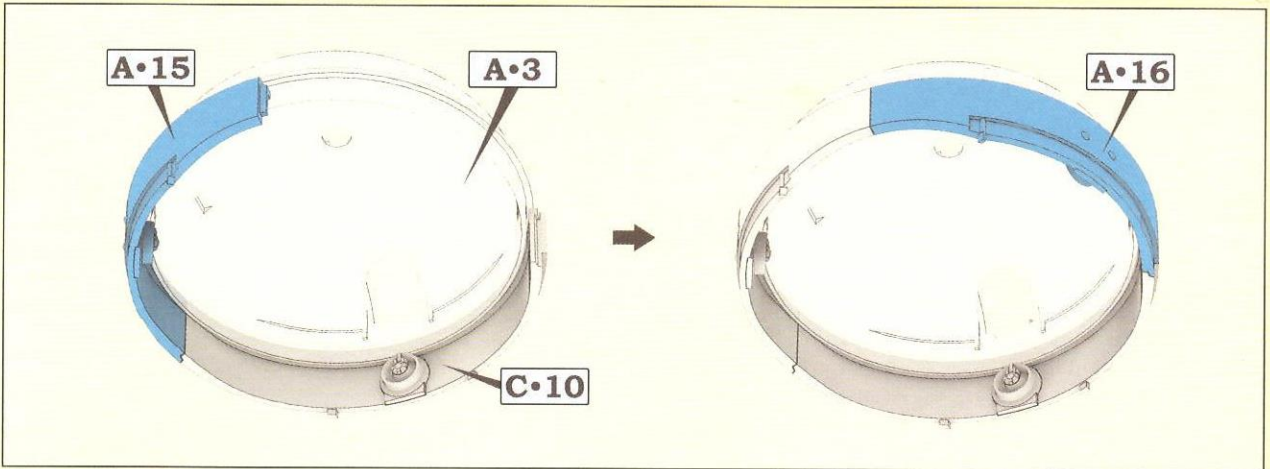

Step 8. Assembling the armoured belt, use part A3 as a template to build the belt about it. Do not glue parts to A3

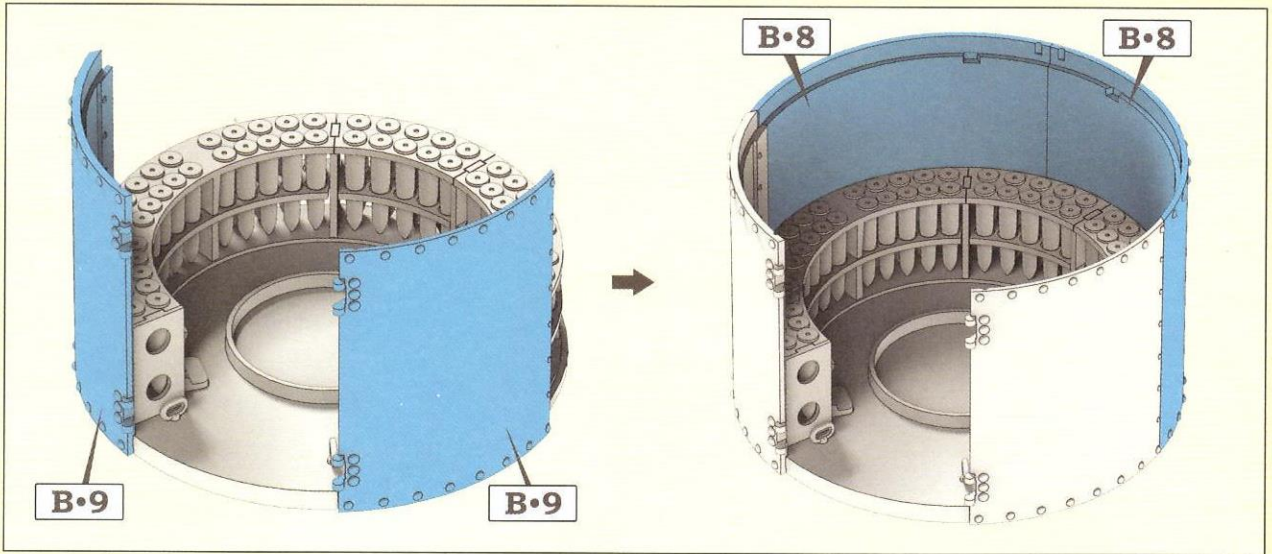

Step 9. Installing the turret walls

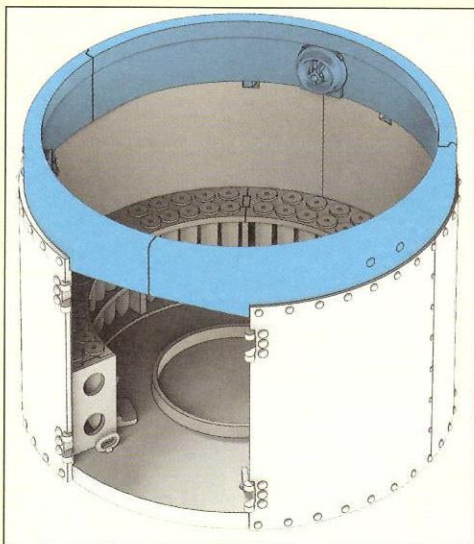

Step 10. Installing the armoured belt

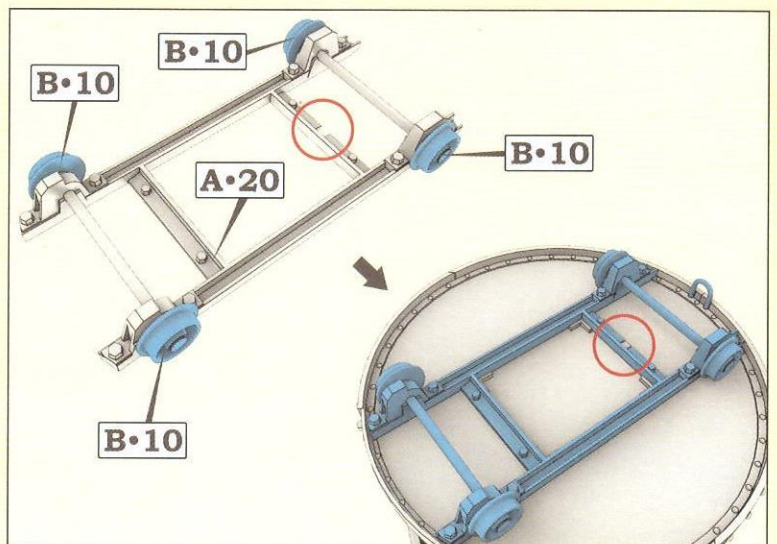

Step 11. Assembling and installing the turret wheels

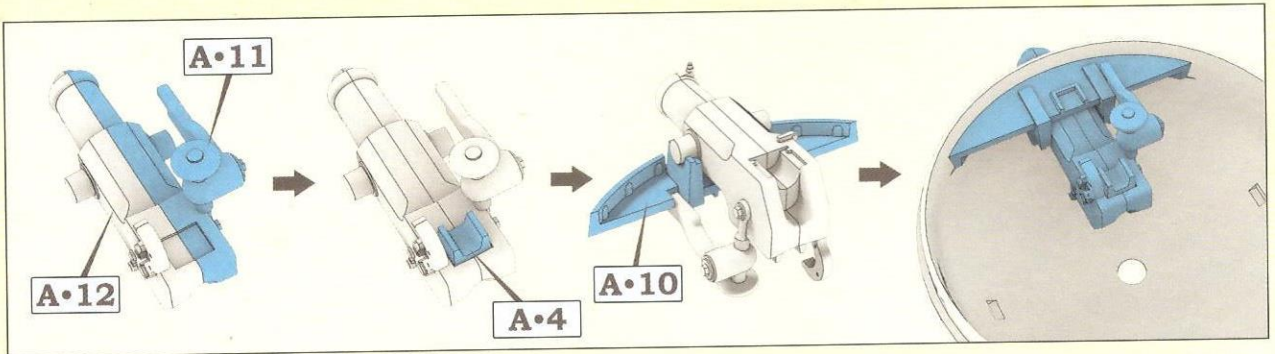

Step 12. Assembling and installing the Gruson gun

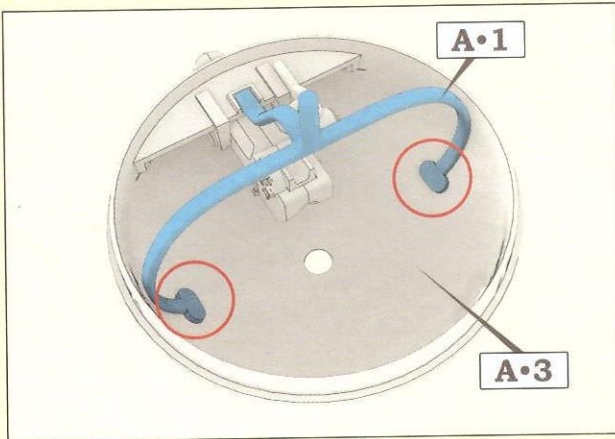

Step 13. Installing the mount on the armoured cupola

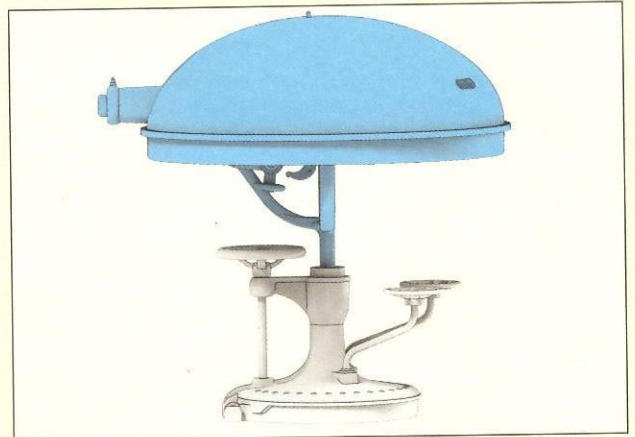

Step 14. Installing the armoured cupola on the base

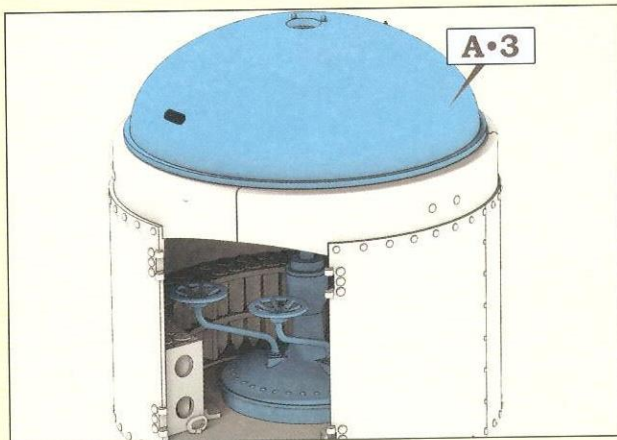

Step 15. Inserting the armoured cupola into the turret

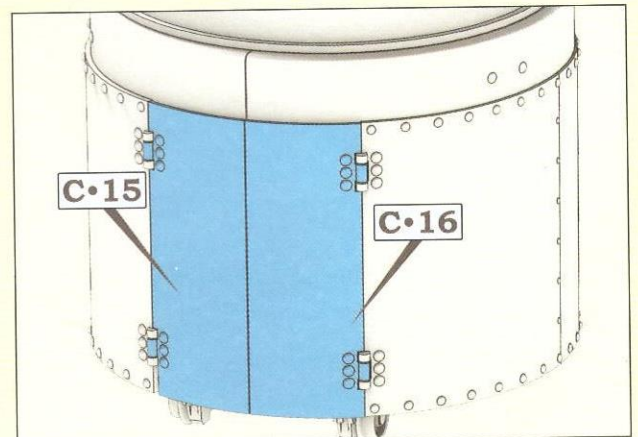

Step 16. Installing the turret doors

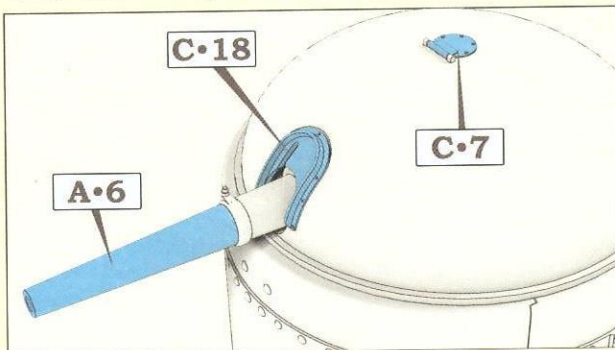

Step 17. Installing the barrel and the cupola hatch

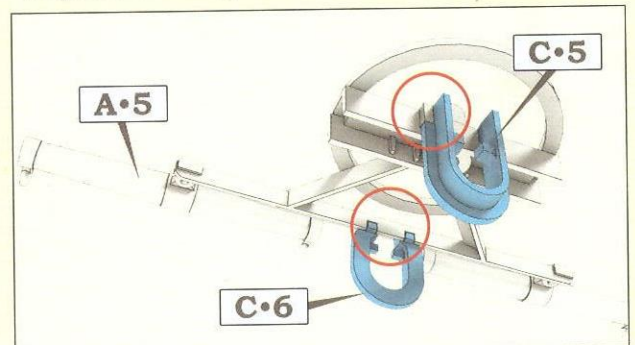

Step 18. Assembling the doubletree

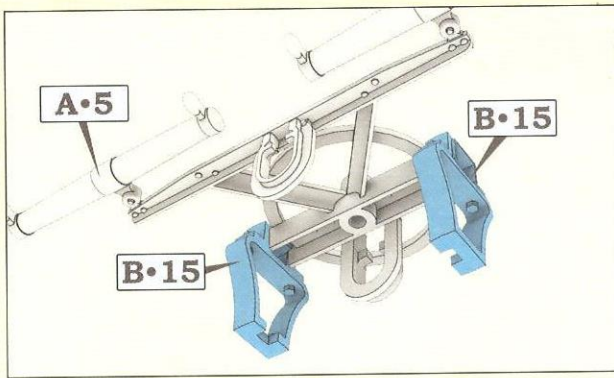

Step 19. Installation of the axle brackets

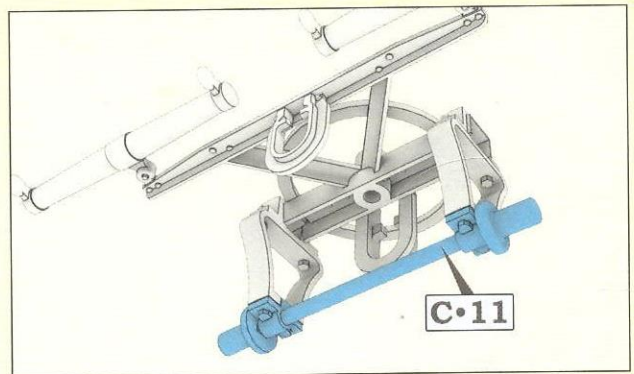

Step 20. Installation of the front axle

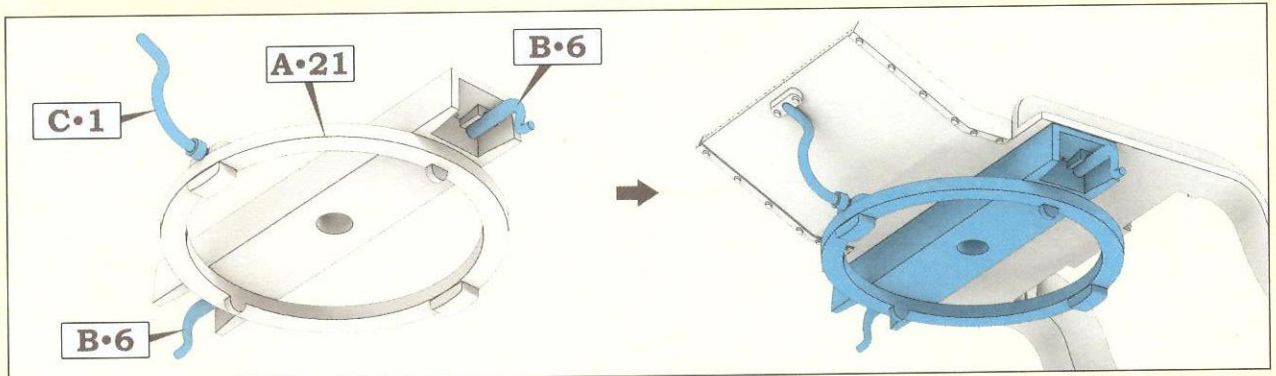

Step 21. Assembling and installing the fifth wheel platform

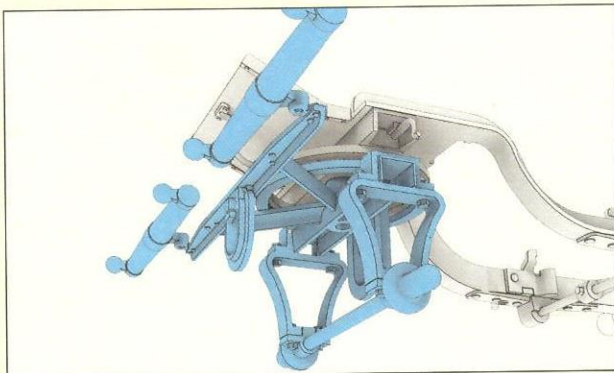

Step 22. Installation of the assembled fifth wheel platform

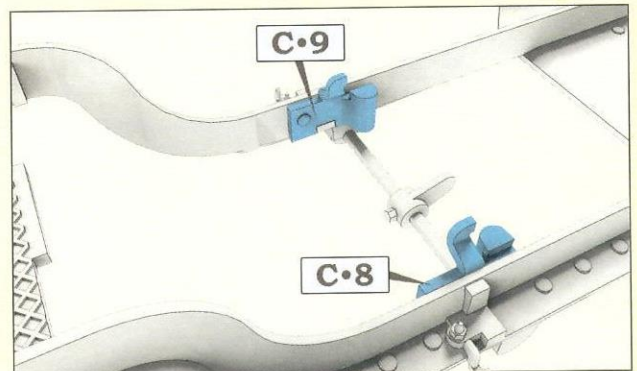

Step 23. Installation of the brake stoppers

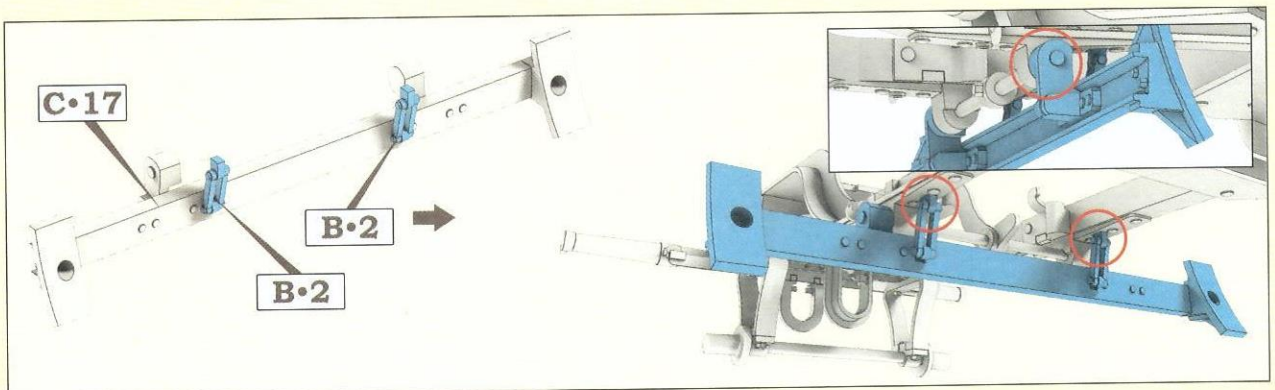

Step 24. Assembling and installing the brake beam

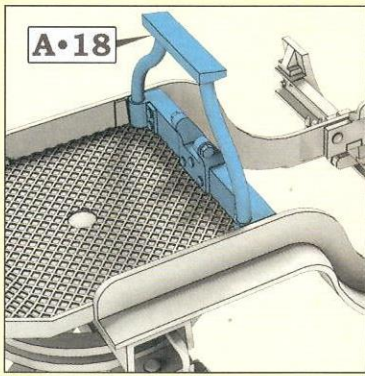

Step 25. Installation of the seat mount

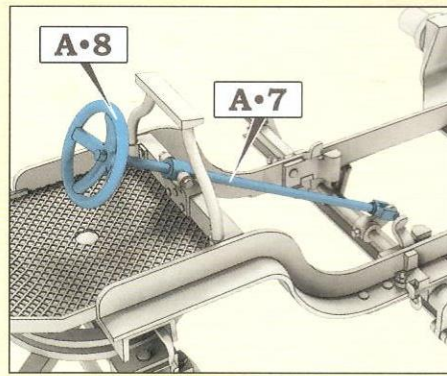

Step 26. Installation of the breaking flywheel

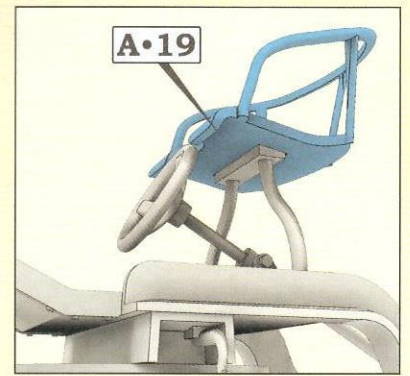

Step 27. Installation of the seat

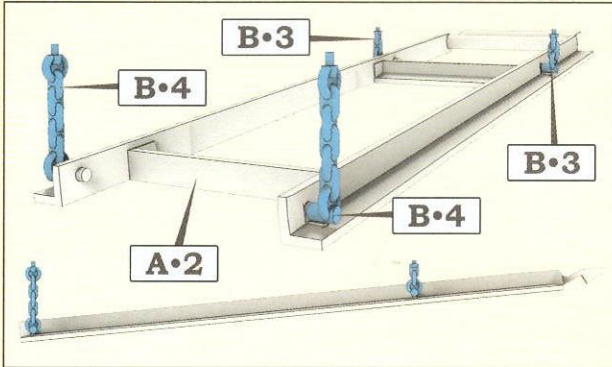

Step 28. Assembling the additional track section

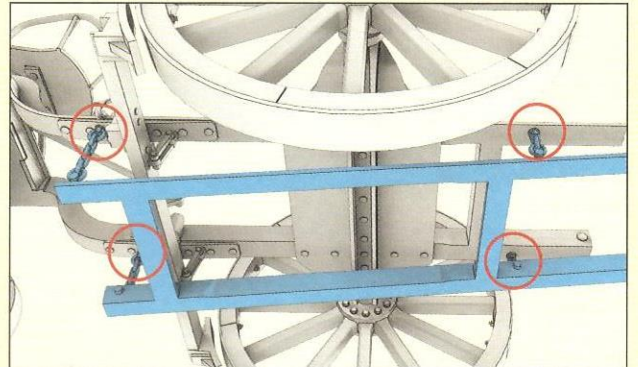

Step 29. Installing the additional track section

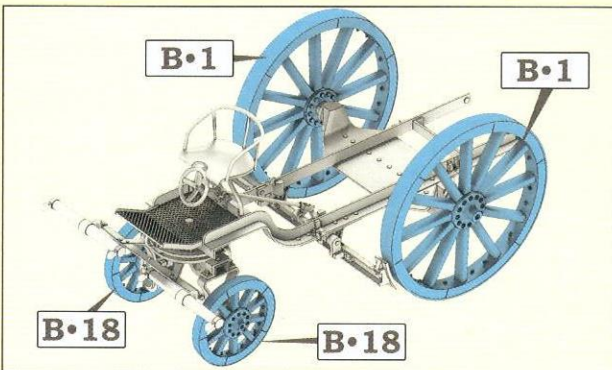

Step 30. Installation of the wheels

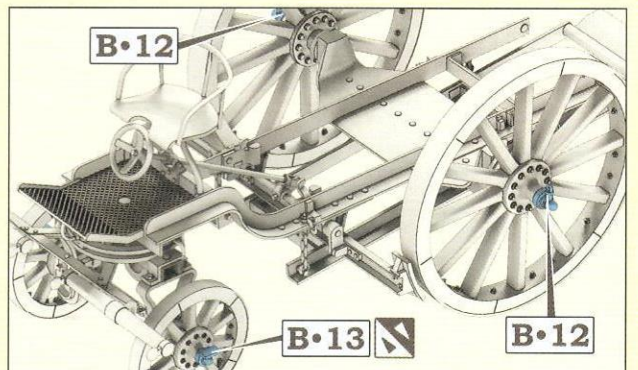

Step 31. Installation of the footstep and rear hub caps

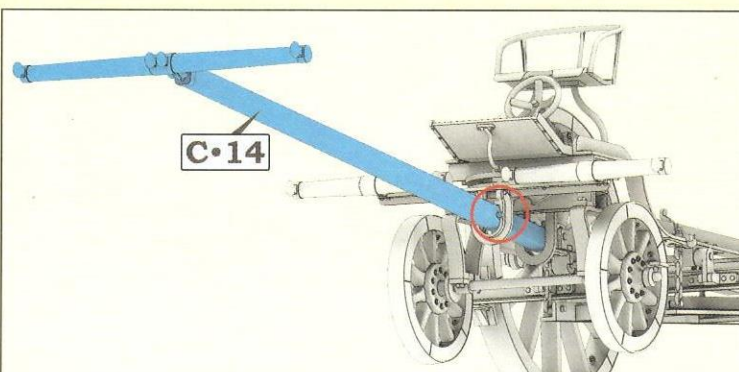

Step 32. Installation of the tongue

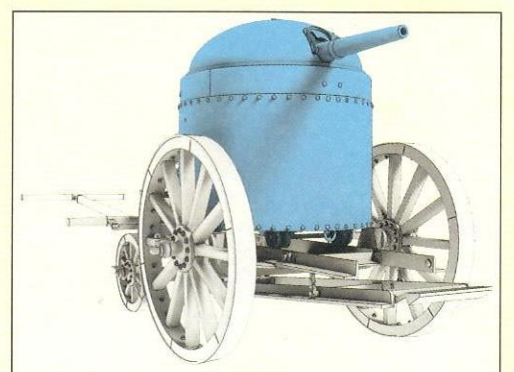

Step 33. Placing the turret on the carriage

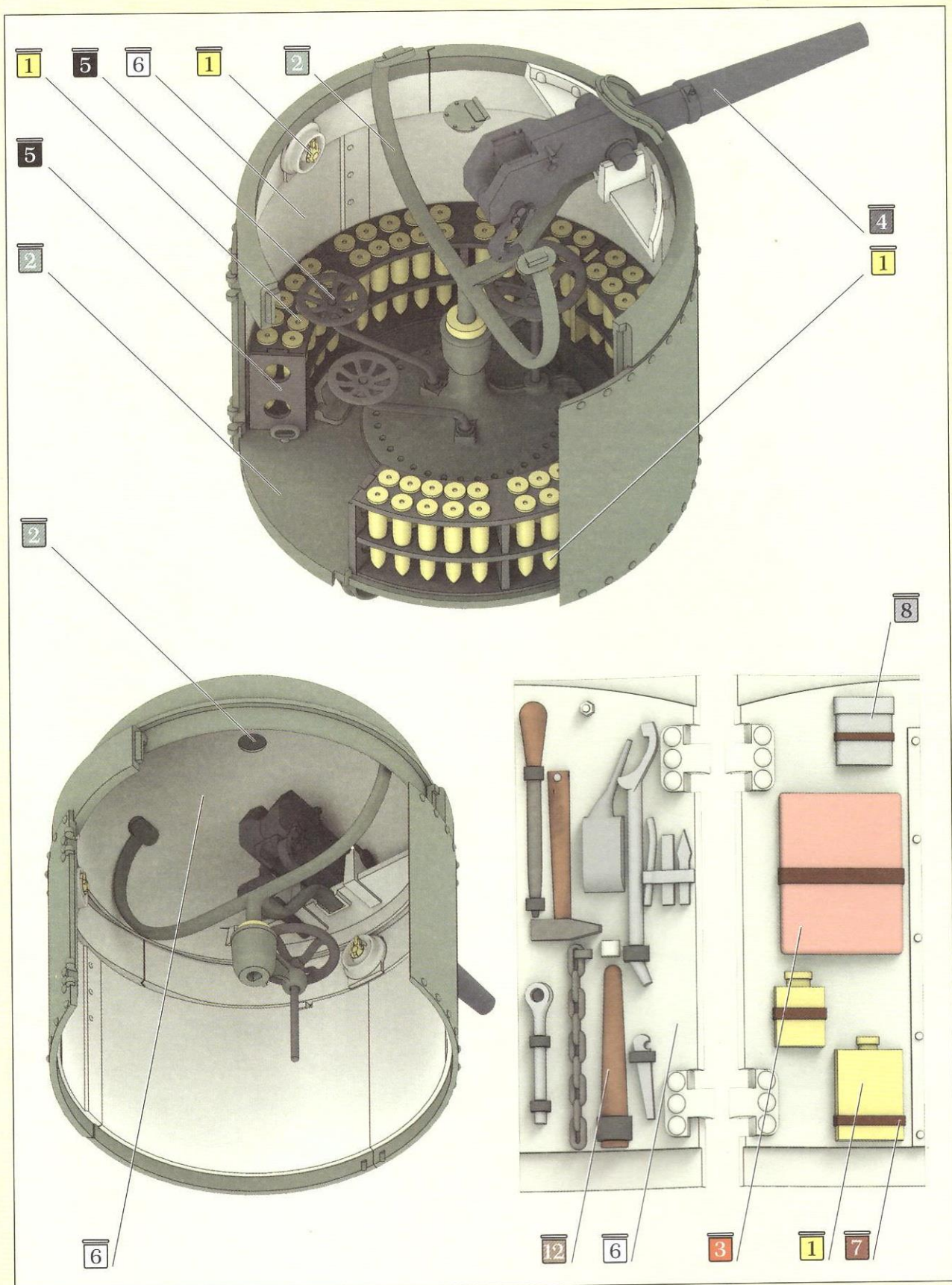

Fig. 4. Interior colours

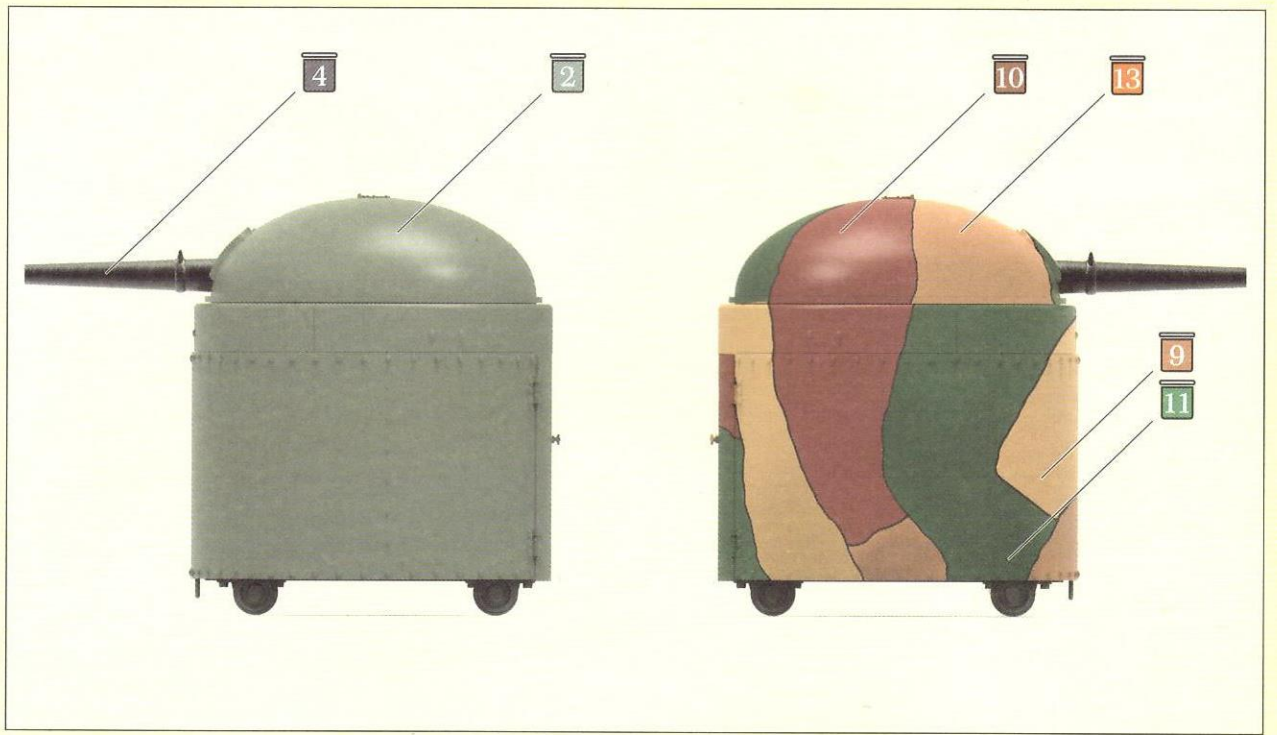

Fig. 5. Camouflaged and field-grey painted versions of the Fahrpanzer

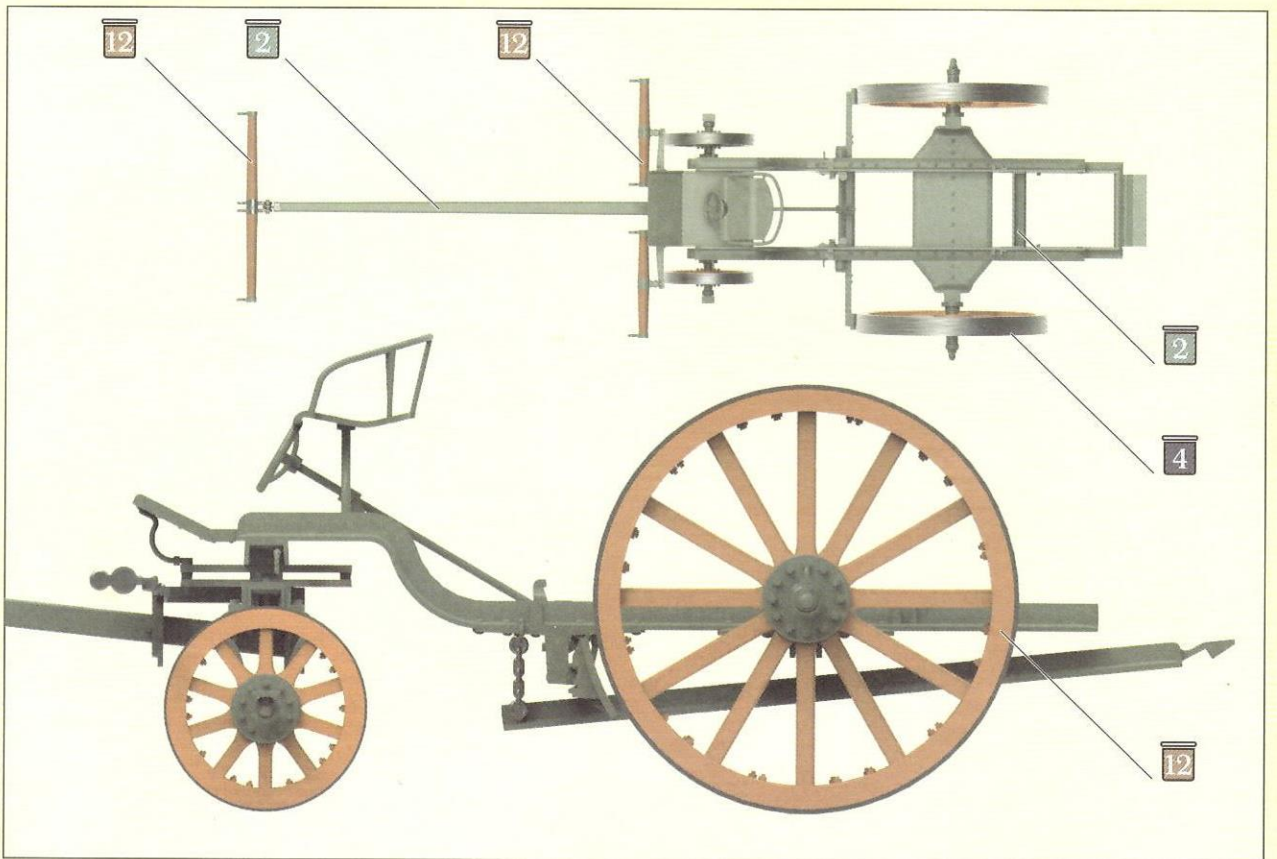
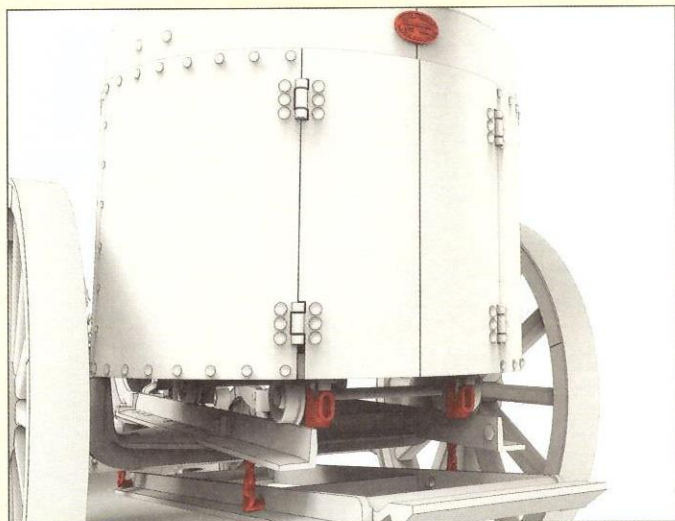
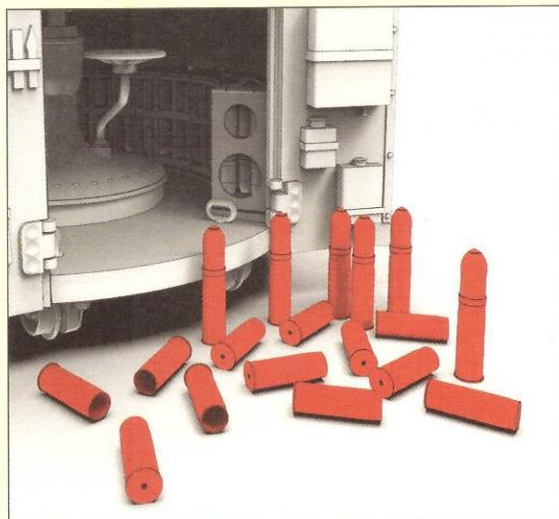

Fig. 6. Colours for the carriage



A35-030. Fahrpanzer exterior. The set consists of chains, Gruson factory plate and sliding bolt locks (for each wheel)



A35-031. Fahrpanzer Gruson shells. The set consists of shells and shell cases

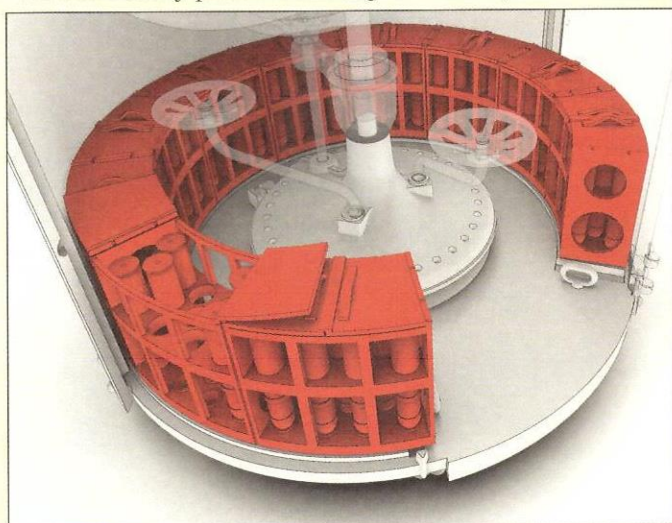

A35-032. Fahrpanzer ammunition boxes. The set consists of 8 full, 1 empty and 1 open ammunition boxes.

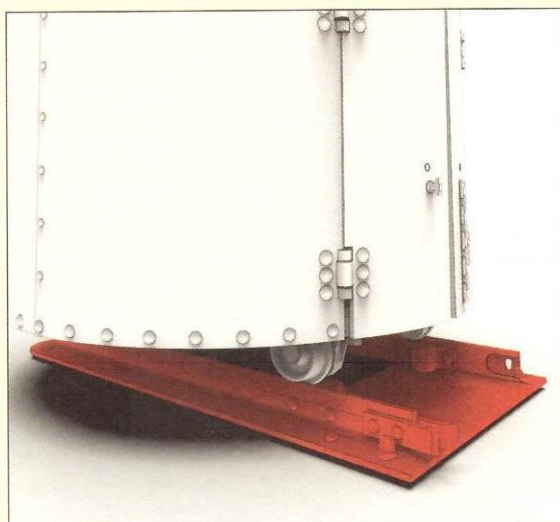

A35-033. Fahrpanzer railway track. One part in the set

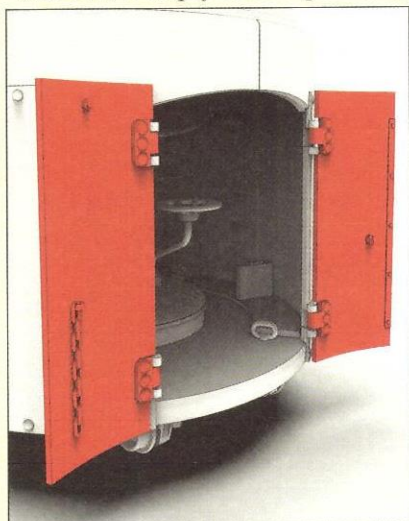

A35-034. Fahrpanzer doors. Two parts in the set

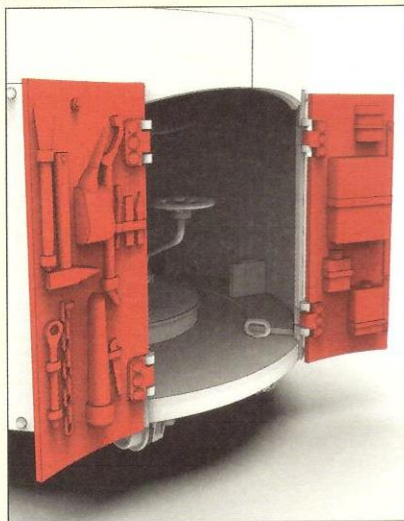

A35-035. Fahrpanzer doors with equipment. Two parts in the set

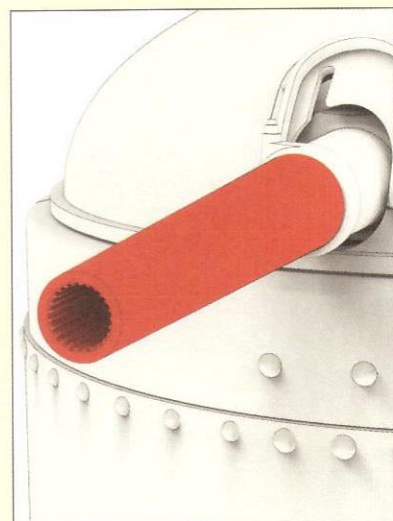

A35-029. Gruson Rifled Barrel for Fahrpanzer. One part in the set

CSM SIA
Cesvaines 4, LV-1073,
Riga, Latvia



Visit our website
www.copperstatemodels.com

2023