

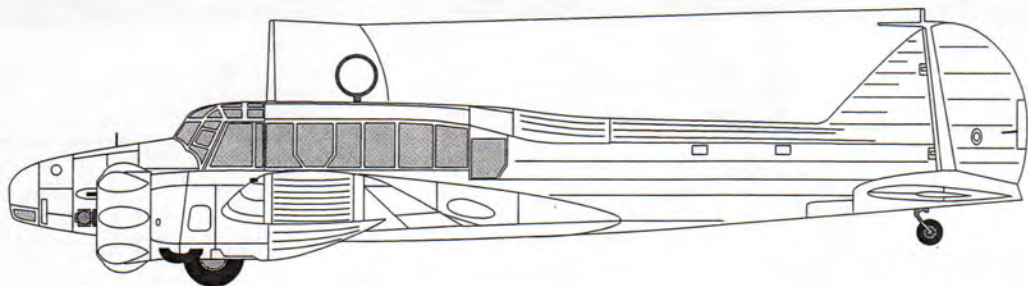

Classic Airframes



Anson Mk. I

The classic Anson had its origins in the model 652 civil transport aircraft. After two were used very successfully by Imperial Airways, they sparked the interest of the RAF. The military prototype first took to the air in March of 1935 as the model 652A. After a brief trial period, the RAF ordered a production run of 174 aircraft. The Anson had the distinction of being the first monoplane and the first aircraft equipped with retractable landing gear to be used by the RAF. Operational service began in March 1936. The outbreak of World War II found the Anson engaged in the anti-submarine and maritime reconnaissance roles, with the first successful attack on a U-boat occurring on December 13, 1939 which resulted in the sinking of the submarine. As newer and faster aircraft began to take the place of the Anson for coastal patrols, the Anson was pressed into service as a navigation and air gunnery trainer. Under the Empire Air Training Plan, Ansons were to be used to train aircrew from Australia, Canada, New Zealand, Rhodesia, and South Africa. Export versions of the Anson were operated by Estonia, Finland, Greece, Turkey and Ireland. The Anson remained in production for 34 years, with 10,996 aircraft being produced.

Anson Mk.1 Specifications

Powerplant:	2x 350hp Cheetah IX radial engines	Armament:	2 machine guns 360 lb. bombload
Wing Span:	56' 6"		
Length:	42' 3"		
Maximum Speed:	-188 mph		

This model kit is intended for *experienced* modelers. The nature of low-pressure molded kits such as this require additional time and effort to clean up and fit the parts, as well as experience with the various media utilized to provide the most accurate effect on the finished model. Use CyA ('super') glue to assemble Resin parts.

Classic Airframes, Inc.
P.O. Box 577580 Chicago, IL 60657-7580 USA

Assembly Instruction Symbols



MULTIPLE ASSEMBLIES



BEND



OPTIONAL



DRILL



CUT



SYMMETRICAL ASSEMBLIES

Paint Reference Guide

A Black-grey	_____	C Burnt Metal	_____	E Aluminum	_____
B Interior Green	-FS 34226	D Silver	_____	F Gunmetal	_____

Parts

PLASTIC PARTS

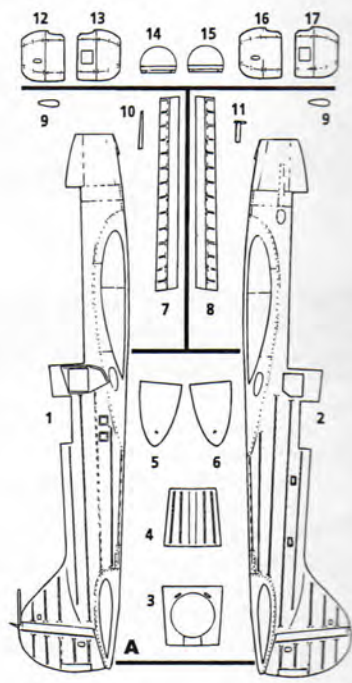
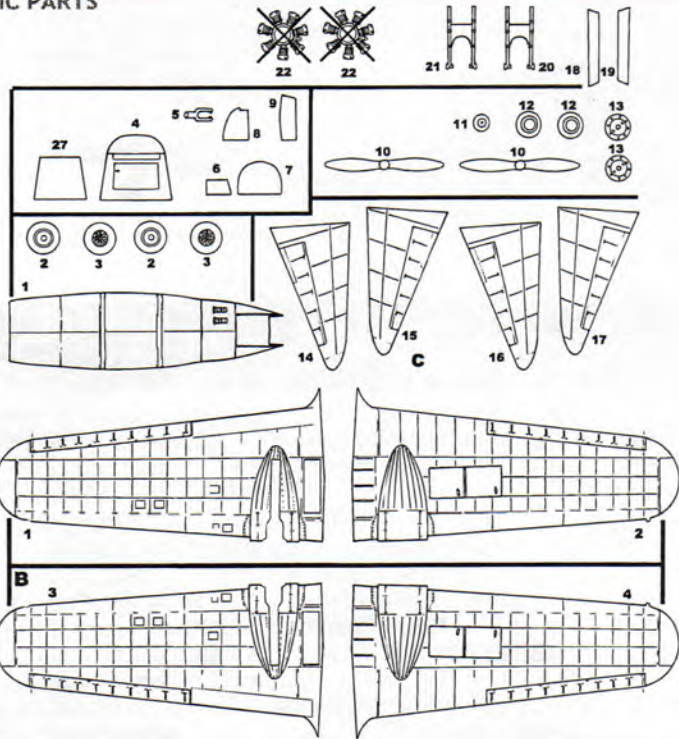

RESIN PARTS

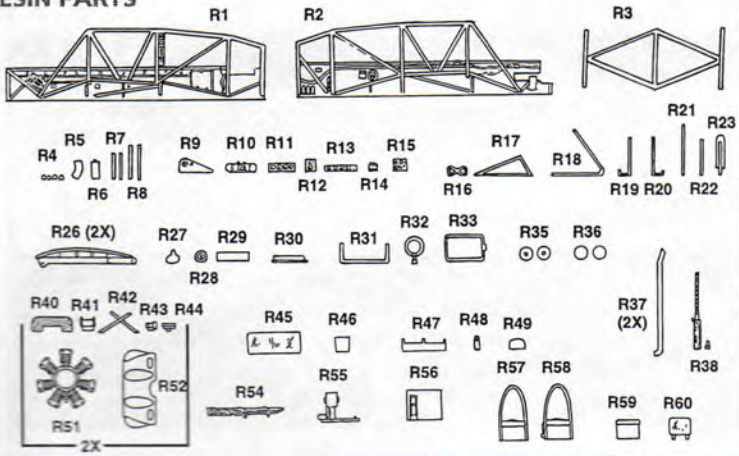

CLEAR PARTS (CP)

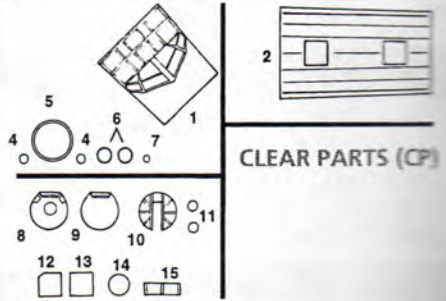

PHOTOETCH/FILM

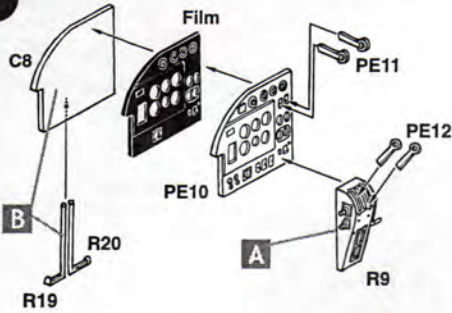

1

Panel PP10 is Satin Black with Silver details

Note alignment of finished assembly.

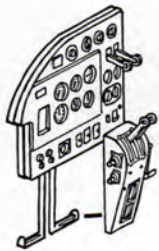
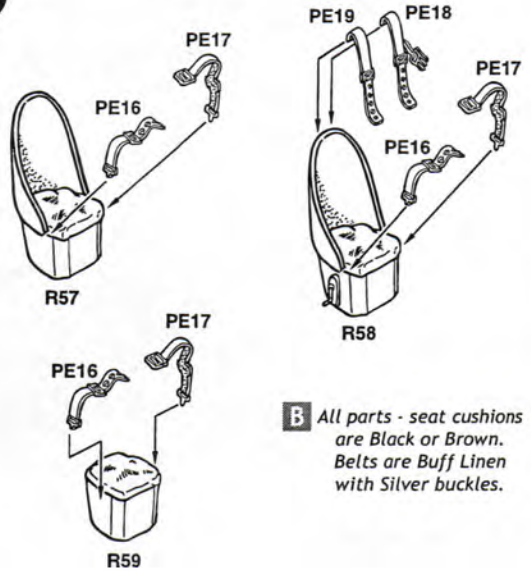
**2**

B All parts - seat cushions are Black or Brown. Belts are Buff Linen with Silver buckles.

NOTE - Be sure to dry-fit and check alignment of all parts during assembly

3

? Fixed machine gun (Part R38) is provided as an option. Refer to Steps 5/6 if you are using the fixed gun, as you will either need to open the rear of the gun port on the left fuselage half (Part A2), or separate the barrel of the gun. If you choose to separate the barrel, install the main body of the gun in this step, then install the barrel to the gun port in Step 6.

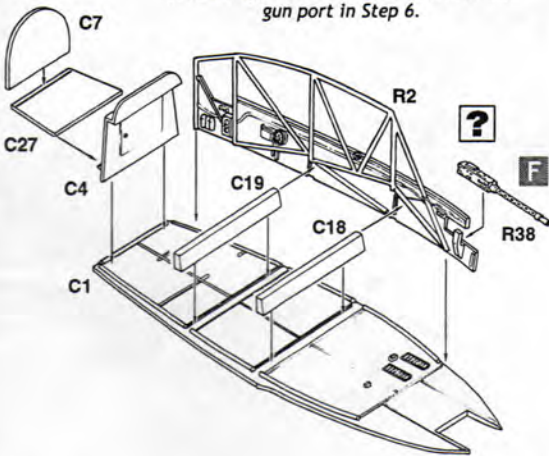

B All interior parts

4

B All interior parts

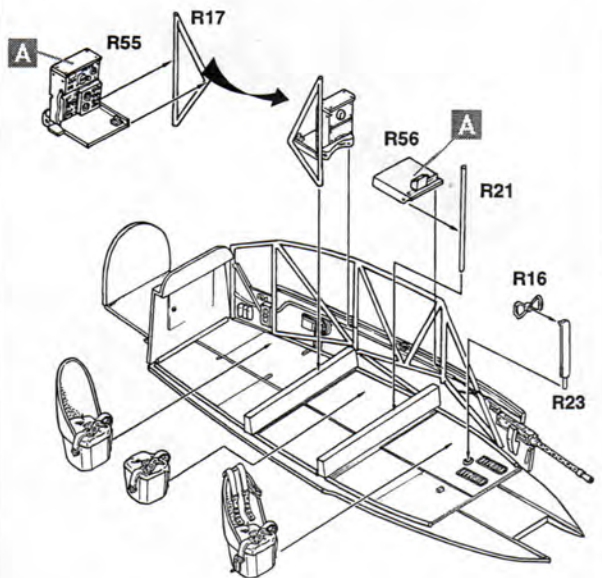

5 **?** Please check your references for the arrangement of nose windows for the aircraft you are modeling. You will need to carefully drill out the holes to install the small nose windows.

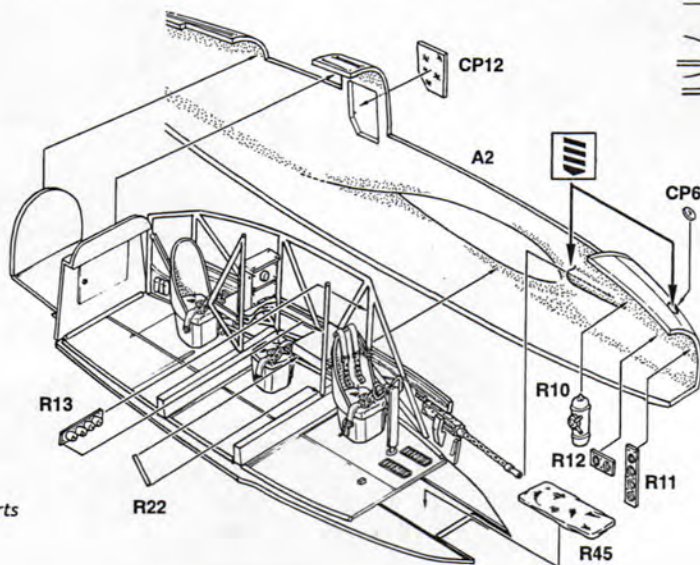

B All interior parts

Panels R11/12/13 are Satin Black with Silver details. Cushion R45 is either Black or Brown.

NOTE - Be sure to dry-fit and check alignment of all parts during assembly

6

B All interior parts

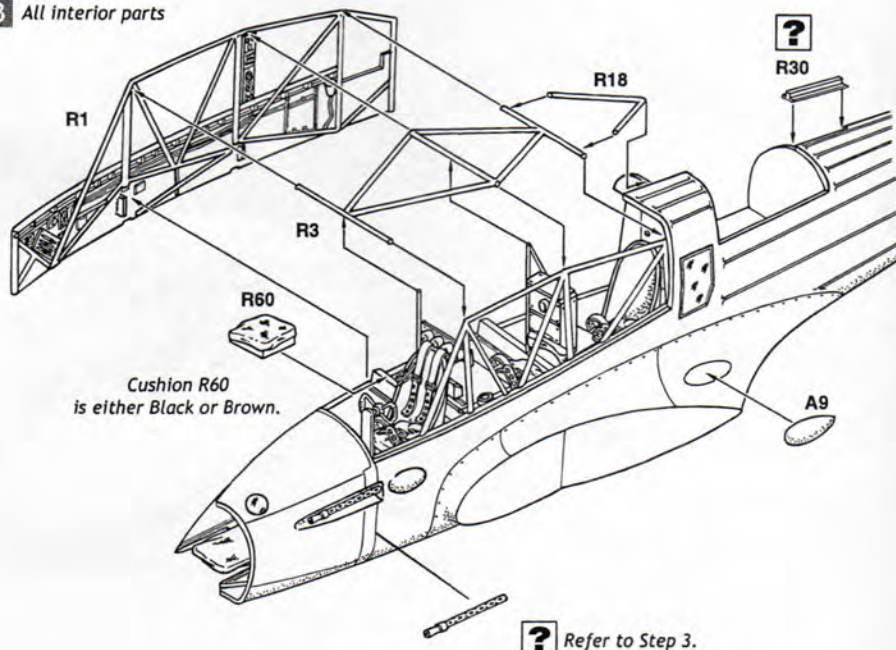

? Refer to Step 3.

7 **?**

Please check your references for the arrangement of nose windows for the aircraft you are modeling.
You will need to carefully drill out the holes to install the small nose windows.

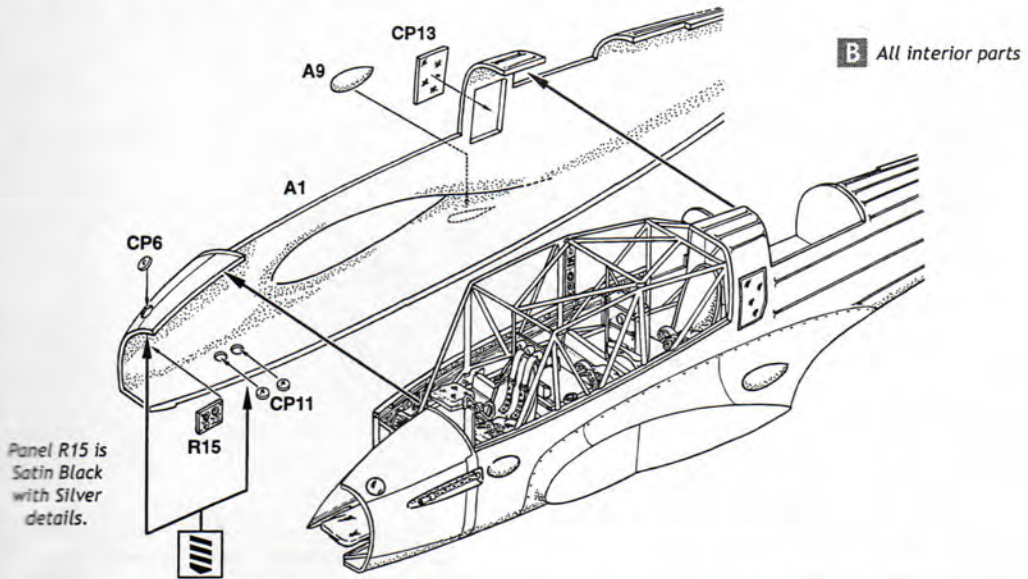

NOTE - Be sure to dry-fit and check alignment of all parts during assembly

8

B All interior parts

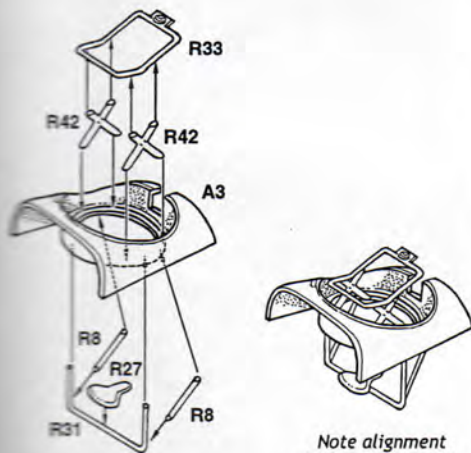

Seat R27 is either Black or Brown.

9

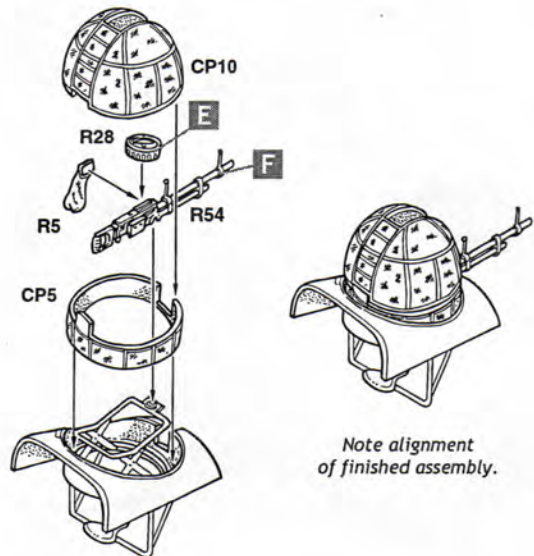

10

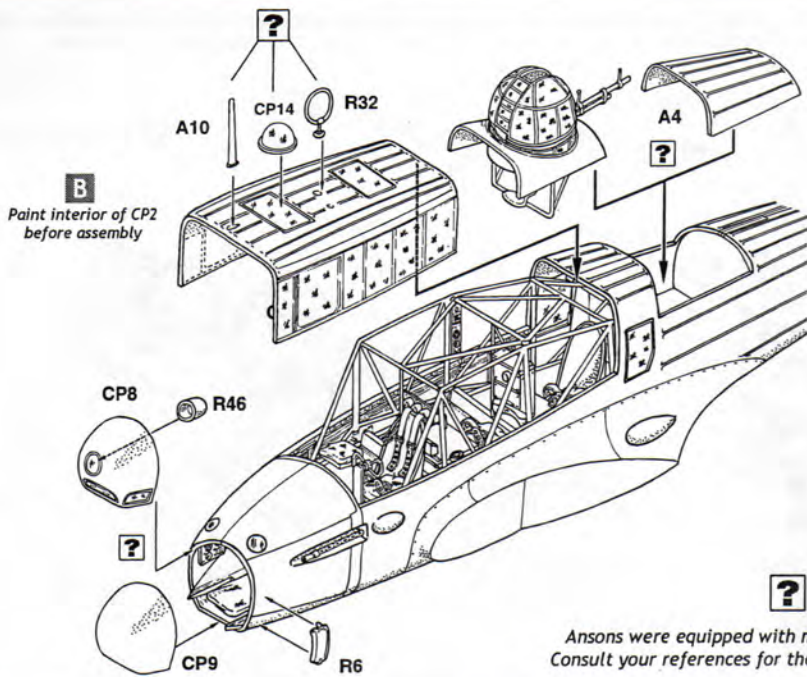

NOTE - Be sure to dry-fit and check alignment of all parts during assembly

11

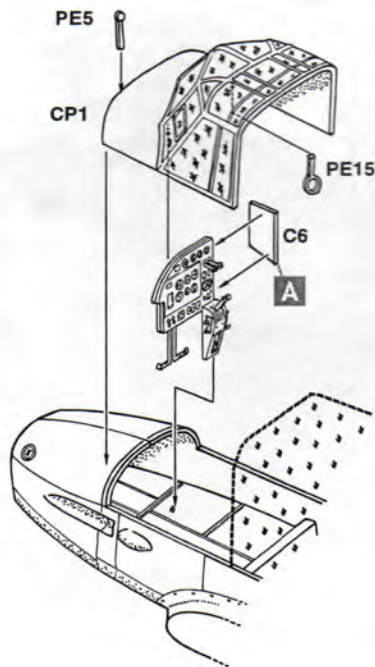

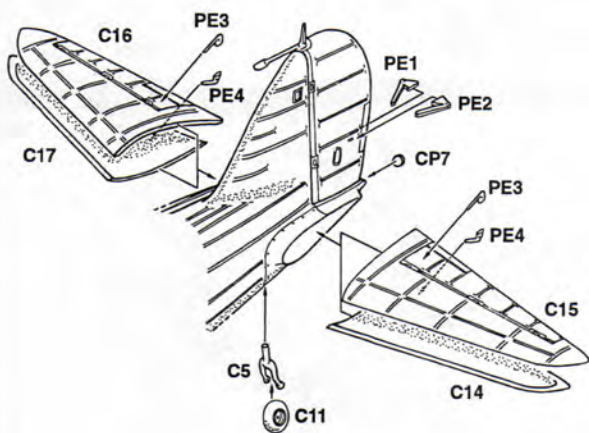
14**15**

NOTE
All part numbers and assemblies
are identical for both engines

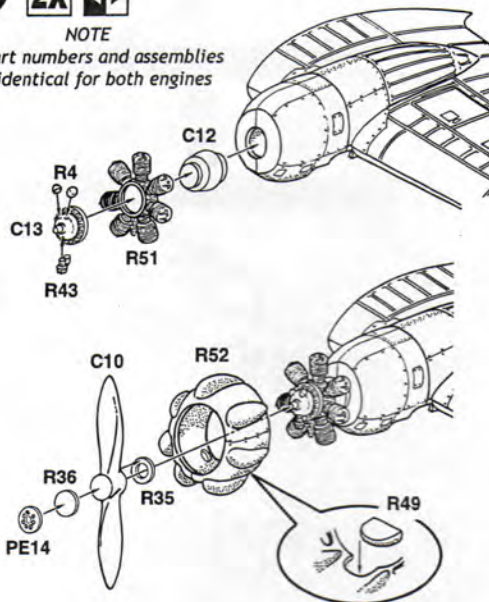

NOTE - Be sure to dry-fit and check alignment of all parts during assembly

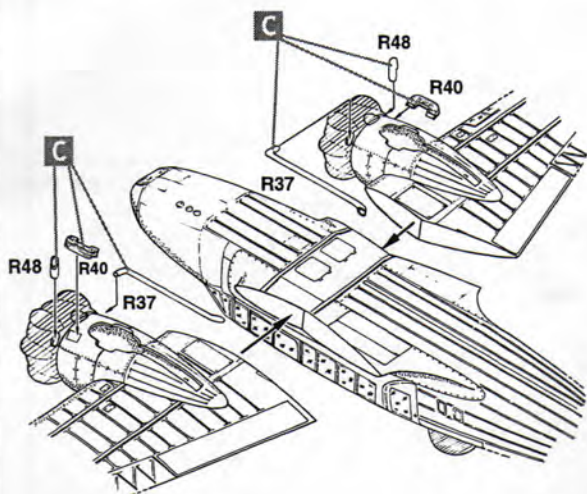
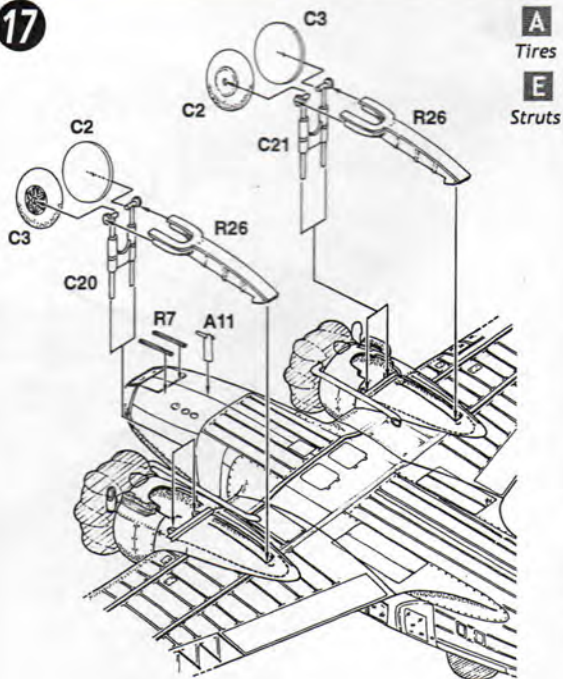
16**17**

Classic Airframes #4119 • Export Anson Color & Marking Guide

Greek Air Force, Africa, circa 1941

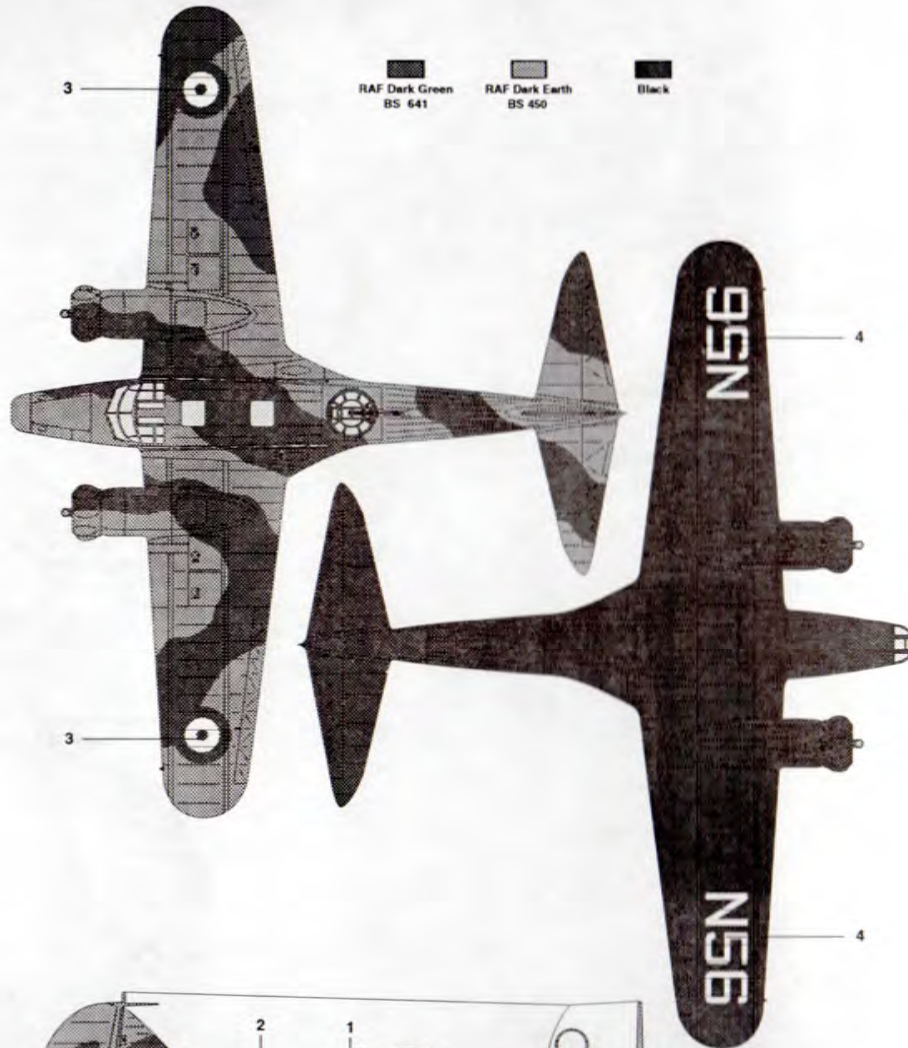
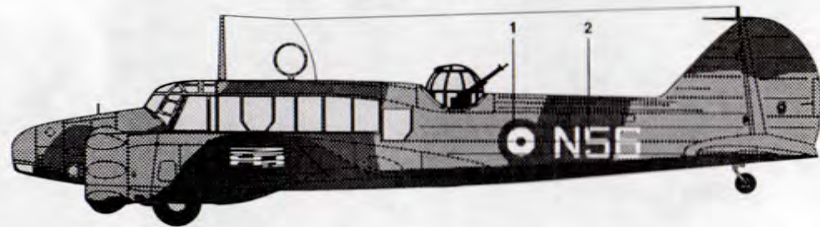

RAF Dark Green
BS 641
 RAF Dark Earth
BS 450
 Black

• Turkish Air Force, circa 1940

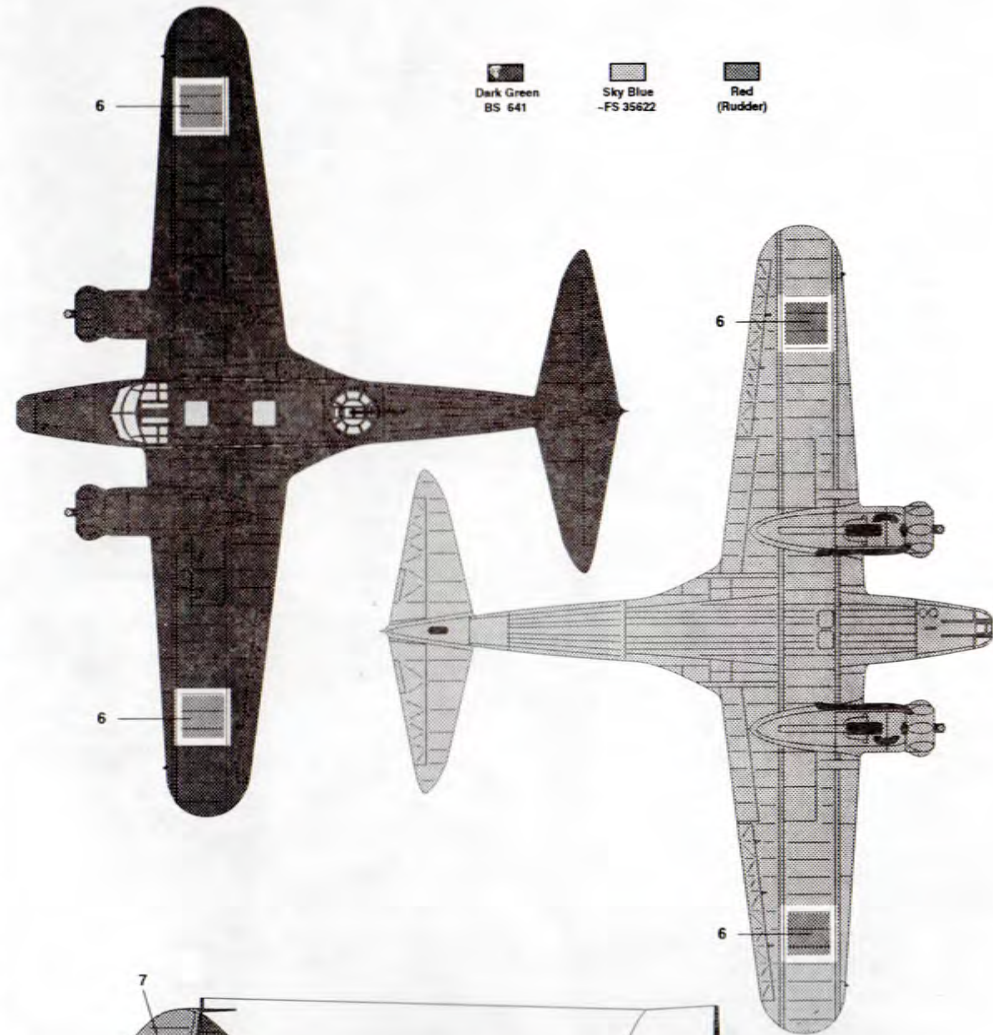
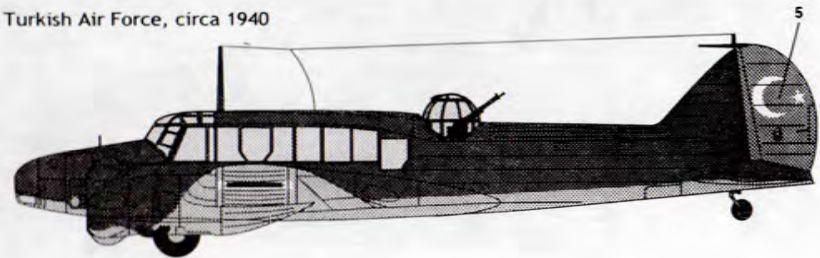

Dark Green
BS 641
 Sky Blue
-FS 35622
 Red
(Rudder)

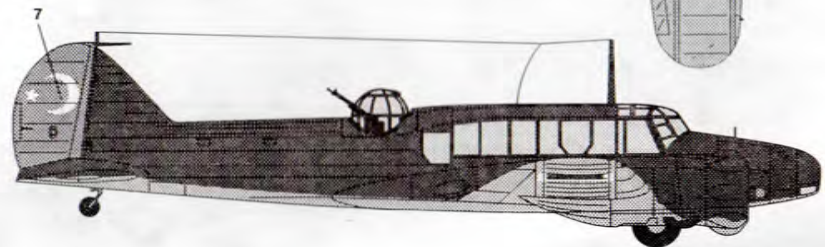

Classic Airframes #4119 • Export Anson Color & Marking Guide

No. 5 SFTS RAAF, Uranquinty, New South Wales, circa 1945

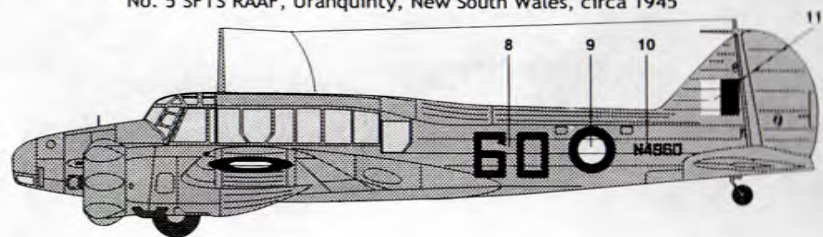

RAF Identification Yellow
-BS 356

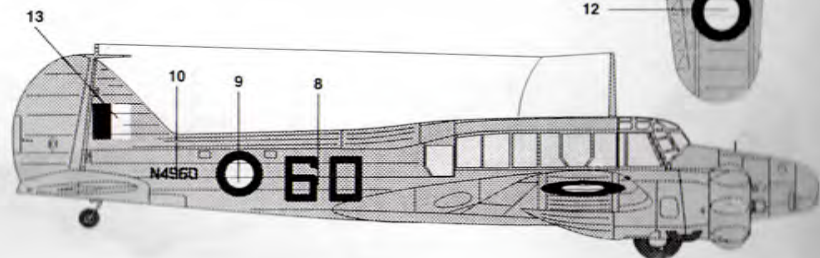
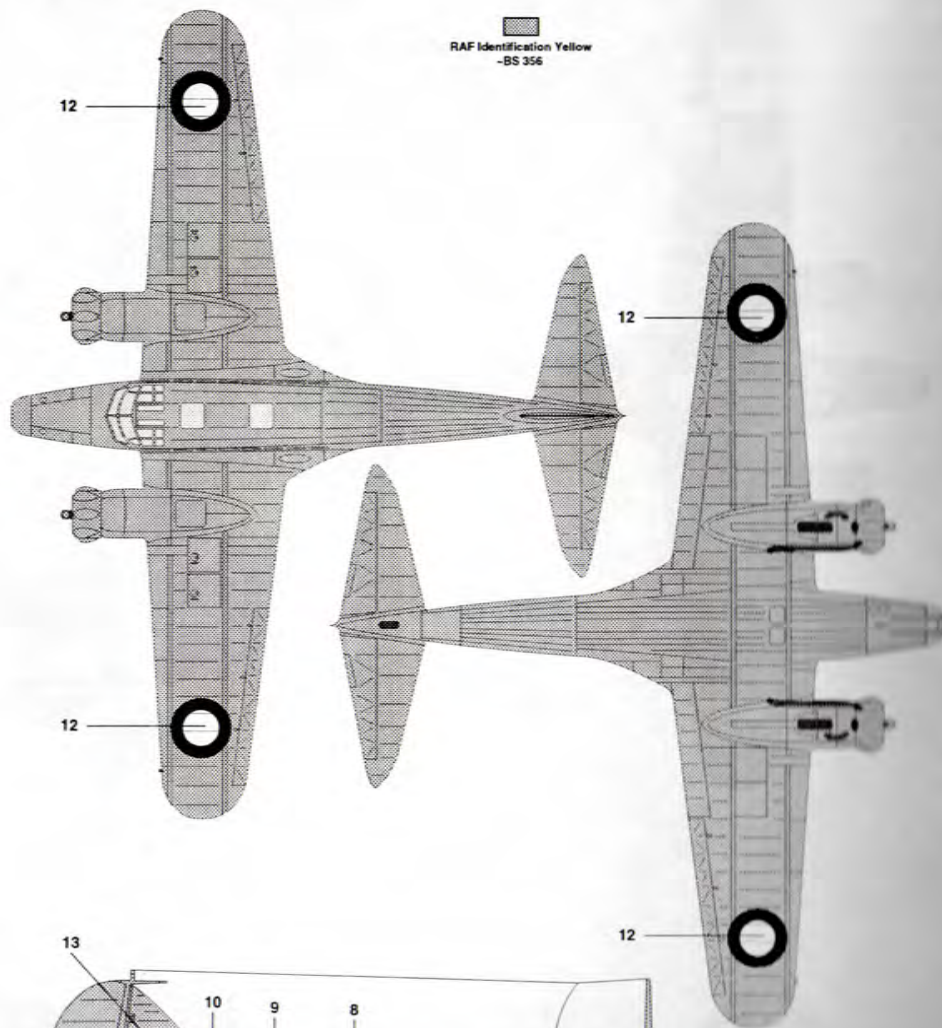

• RAAF Survey Flight, circa 1946

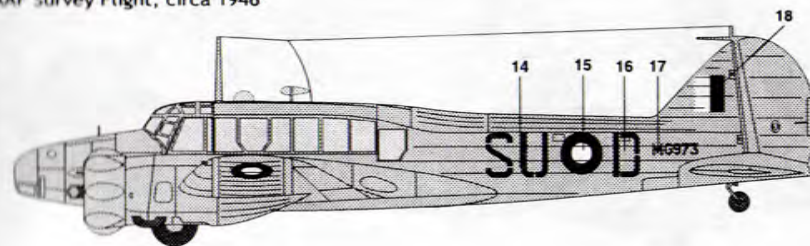

Aluminum

